

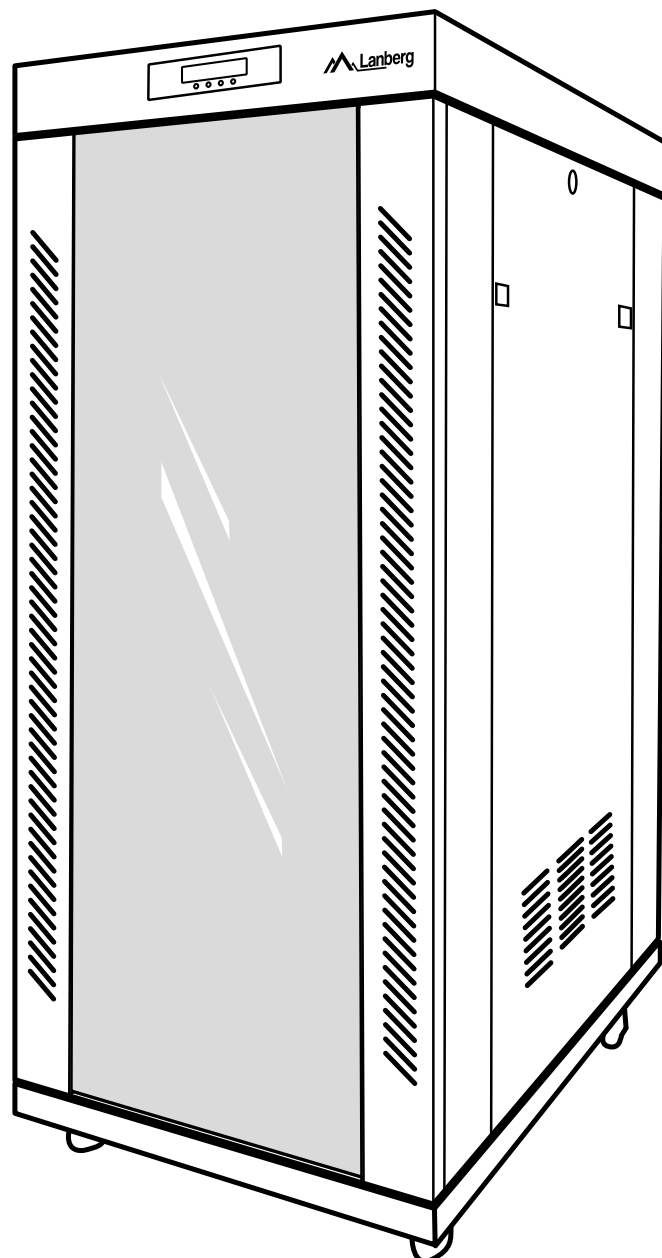

19" Rack cabinets with panel LCD GREY

FF01 12U, 15U, 22U, 27U, 32U, 37U, 42U, 47U | 600*600, 600*800, 600*1000, 600*1200

User's manual



EN 3
FR 10
ES 17
PT 24
DE 31
SE 38
IT 45
PL 52
CZ 59
SK 66
RO 73
BG 80
HU 87
RS 94
RU 101
GR 108

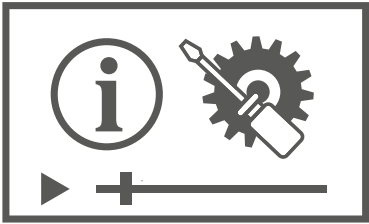



EN Safety information:

Installation by minimum 2 persons only.
 Secure the cabinet to the floor or wall at designated anchoring points.
 Do not exceed total load capacity or shelf / 1U load.
 Install the heaviest equipment at the lowest positions (first bottom U).
 Distribute the load evenly; secure equipment with mounting screws.
 Before moving, remove all equipment and lock the doors.
 Use only recommended casters and mounting hardware — check load rating.
 Ground the cabinet according to local grounding requirements for equipment and metal enclosures.
 Maintain required ventilation clearances — do not block perforations.
 Beware of sharp edges — protective gloves recommended.
 Periodic inspection: check fasteners every 12 months; verify grounding per local requirements.
 Do not use outdoors or in high-humidity or corrosive environments.

FR Instructions de sécurité :

Installation par au moins 2 personnes.
 Fixer l'armoire au sol ou au mur aux points d'ancrage prévus.
 Ne pas dépasser la charge totale ni la charge par étagère / 1U.
 Installer les équipements les plus lourds en bas (premier U inférieur).
 Répartir la charge uniformément ; fixer les appareils avec des vis.
 Avant de déplacer, retirer tout l'équipement et verrouiller les portes.
 Utiliser uniquement les roulettes et fixations recommandées — vérifier la capacité de charge.
 Mettre l'armoire à la terre conformément aux exigences locales pour les équipements et boîtiers métalliques.
 Maintenir les dégagements de ventilation requis — ne pas obstruer les perforations.
 Attention aux bords tranchants — gants de protection recommandés.
 Contrôles périodiques : vérifier les fixations tous les 12 mois ; vérifier la mise à la terre selon les exigences locales.
 Ne pas utiliser à l'extérieur ni en environnement humide ou corrosif.

ES Instrucciones de seguridad:

Instalación únicamente por un mínimo de 2 personas.
 Fijar el armario al suelo o pared en los puntos designados.
 No exceder la carga total ni la carga por estante / 1U.
 Instalar los equipos más pesados en la parte inferior (primer U inferior).
 Distribuir la carga de manera uniforme; asegurar los equipos con tornillos de montaje.
 Antes de mover, retirar todo el equipo y bloquear las puertas.
 Usar solo ruedas y elementos de fijación recomendados — comprobar la capacidad de carga.
 Conectar a tierra el armario de acuerdo con los requisitos locales de puesta a tierra para equipos y envoltorios metálicos.
 Mantener los espacios de ventilación requeridos — no bloquear las perforaciones.
 Cuidado con los bordes cortantes — se recomiendan guantes de protección.
 Inspecciones periódicas: comprobar los anclajes cada 12 meses; revisar la puesta a tierra según los requisitos locales.
 No usar en exteriores ni en entornos de alta humedad o corrosivos.

PT Instruções de segurança:

Instalação por no mínimo 2 pessoas.
 Fixar o armário ao chão ou parede nos pontos de ancoragem indicados.
 Não exceder a capacidade de carga total nem a carga por prateleira / 1U.
 Instalar os equipamentos mais pesados na parte inferior (primeiro U inferior).
 Distribuir a carga de forma uniforme; fixar os equipamentos com parafusos de montagem.
 Antes de deslocar, remover todo o equipamento e travar as portas.
 Usar apenas rodízios e elementos de fixação recomendados — verificar a capacidade de carga.
 Aterre o armário conforme os requisitos locais de aterramento para equipamentos e invólucros metálicos.
 Manter os espaços de ventilação exigidos — não bloquear as perfurações.
 Cuidado com bordas cortantes — luvas de proteção recomendadas.
 Inspeções periódicas: verificar as fixações a cada 12 meses; verificar o aterramento conforme os requisitos locais.
 Não usar ao ar livre nem em ambientes de alta humidade ou corrosivos.

DE Sicherheitshinweise:

Montage nur durch mindestens 2 Personen.
 Schrank an Boden oder Wand an den vorgesehenen Befestigungspunkten verankern.
 Gesamttraglast sowie Traglast pro Fach / 1U nicht überschreiten.
 Die schwersten Geräte an den unteren Positionen installieren (erstes unteres U).
 Die Last gleichmäßig verteilen; Geräte mit Montageschrauben sichern.
 Vor dem Transport sämtliche Geräte entfernen und Türen verriegeln.
 Nur empfohlene Rollen und Befestigungsmaterial verwenden — Tragfähigkeit prüfen.
 Den Schrank gemäß den lokalen Erdungsanforderungen für Geräte und Metallgehäuse erden.
 Energie- und Belüftungsabstände einhalten — Perforationen nicht blockieren.
 Vorsicht vor scharfen Kanten — Schutzhandschuhe empfohlen.
 Periodische Überprüfung: Befestigungen alle 12 Monate prüfen; Erdung gemäß lokalen Vorschriften verifizieren.
 Nicht im Freien oder in Bereichen mit hoher Luftfeuchtigkeit oder korrosiven Bedingungen verwenden.

SE Säkerhetsinstruktioner:

Montering endast av minst 2 personer.
 Fäst skåpet i golvet eller väggen vid angivna förankringspunkter.
 Överskrid inte den totala lastkapaciteten eller last per hylla / 1U.
 Installera de tyngsta enheterna i de lägsta positionerna (första nedre U).
 Fördela lasten jämnt; säkra utrustningen med monteringskruvar.
 Innan förflyttning, ta bort all utrustning och lås dörrarna.
 Använd endast rekommenderade hjul och fästelement — kontrollera lastkapacitet.
 Jorda skåpet enligt lokala jordningskrav för utrustning och metallhöljen.
 Behåll erforderliga ventilationsutrymmen — blockera inte perforeringar.
 Se upp för vassa kanter — skyddshandskar rekommenderas.
 Periodisk inspektion: kontrollera fästen var 12:e månad; verifiera jordning enligt lokala krav.
 Använd inte utomhus eller i miljöer med hög luftfuktighet eller korrosiva förhållanden.

IT Istruzioni di sicurezza:

Installazione esclusivamente da parte di almeno 2 persone.
 Fissare l'armadio al pavimento o alla parete nei punti di ancoraggio indicati.
 Non superare il carico totale né il carico per ripiano / 1U.
 Installare le apparecchiature più pesanti nelle posizioni più basse (primo U inferiore).
 Distribuire uniformemente il carico; fissare le apparecchiature con viti di montaggio.
 Prima dello spostamento, rimuovere tutte le apparecchiature e bloccare le porte.
 Usare solo ruote e elementi di fissaggio raccomandati — verificare la portata.
 Collegare a terra l'armadio secondo i requisiti locali per la messa a terra di apparecchiature e involucri metallici.
 Mantenere i necessari spazi di ventilazione — non ostruire le perforazioni.
 Attenzione ai bordi taglienti — guanti protettivi consigliati.
 Ispezioni periodiche: controllare i fissaggi ogni 12 mesi; verificare la messa a terra secondo i requisiti locali.
 Non usare all'aperto né in ambienti ad alta umidità o corrosivi

PL Instrukcja bezpieczeństwa:

Montaż wyłącznie przez minimum 2 osoby.
 Przymocować szafę do podłoża lub ściany w oznaczonych punktach kotwienia.
 Nie przekraczać udźwigu całkowitego oraz udźwigu na półkę / 1U.
 Najcięższe urządzenia instalować najniżej (pierwsze dolne U).
 Równomiernie rozłożyć obciążenie; zabezpieczyć urządzenia śrubami montażowymi.
 Przed przemieszczaniem usunąć cały sprzęt i zablokować drzwi.
 Używać tylko zalecanych kółek i elementów mocujących — sprawdzić nośność.
 Uziemić szafę zgodnie z lokalnymi wymogami dotyczącymi uziemiania urządzeń i metalowych obudów.
 Zachować wymagane odstępstwa wentylacyjne — nie zasłaniać perforacji.
 Uważać na ostre krawędzie — zalecane rękawice ochronne.
 Przeglądy okresowe: sprawdzić mocowania co 12 mies.; uziemienie sprawdzić zgodnie z lokalnymi wymogami.
 Nie używać na zewnątrz ani w warunkach wysokiej wilgotności lub korozyjnych.

CZ Bezpečnostní pokyny:

Montáž pouze minimálně dvěma osobami.
Připevňte skříň k podlaze nebo ke stěně v určených bodech kotvení.
Nepřekračujte celkovou nosnost ani nosnost na polici / 1U.
Nejtěžší zařízení instalujte nejnižše (první spodní U).
Zatížení rovnoměrně rozložte; zařízení zajistěte montážními šrouby.
Před přemístěním vyjměte veškeré vybavení a zamkněte dveře.
Používejte pouze doporučená kolečka a upevňovací prvky — zkontrolujte nosnost.
Uzemněte skříň podle místních požadavků na uzemnění zařízení a kovových krytů.
Zachovejte požadované ventilační odstupy — neblokujte perforace.
Dejte pozor na ostré hrany — doporučeny ochranné rukavice.
Pravidelné prohlídky: kontrola upevnění každých 12 měsíců; ověření uzemnění dle místních požadavků.
Nepoužívejte venku ani v podmínkách vysoké vlhkosti nebo korozivních prostředích.

SK Bezpečnostné pokyny:

Montáž výlučne minimálne 2 osobami.
Prípnúť skrinku k podlahe alebo stene v označených bodoch kotvenia.
Neprekračovať celkovú nosnosť ani nosnosť na policu / 1U.
Najťažšie zariadenia inštalovať najnižšie (prvé dolné U).
Rovnomerne rozložiť zaťaženie; zabezpečiť zariadenia montážnymi skrutkami.
Pred presunom odstrániť všetko vybavenie a zamknúť dvere.
Používať len odporúčané kolieska a upevňovacie prvky — skontrolovať nosnosť.
Uzemniť skrinku v súlade s miestnymi požiadavkami na uzemnenie zariadení a kovových krytov.
Zachovať požadované vetracie odstupy — nezakrývať perforácie.
Dávať pozor na ostré hrany — odporúčané ochranné rukavice.
Pravidelné kontroly: skontrolovať upevnenia každých 12 mesiacov; kontrolovať uzemnenie podľa miestnych požiadaviek.
Nepoužívať vonku ani v prostredí s vysokou vlhkosťou alebo korozívnymi podmienkami.

RO Instrucțiuni de siguranță:

Montaj numai de către minimum 2 persoane.
Fixați dulapul de podea sau perete în punctele de ancorare indicate.
Nu depășiți capacitatea totală de încărcare sau sarcina pe raft / 1U.
Instalați echipamentele cele mai grele în pozițiile cele mai joase (primul U inferior).
Distribuiți sarcina uniform; fixați echipamentele cu șuruburi de montaj.
Înainte de mutare, scoateți toate echipamentele și blocați ușile.
Utilizați numai roți și elemente de fixare recomandate — verificați capacitatea de încărcare.
Împământați dulapul conform cerințelor locale pentru împământarea echipamentelor și carcaselor metalice.
Păstrați spațiile de ventilație necesare — nu blocați perforațiile.
Aveți grijă la muchii ascuțite — mănuși de protecție recomandate.
Inspecții periodice: verificați elementele de fixare la fiecare 12 luni; verificați împământarea conform cerințelor locale.
Nu utilizați în aer liber sau în medii cu umiditate ridicată sau corozive.

BG Инструкции за безопасност:

Монтаж само от минимум 2 души.
Закрепете шкафа към пода или стената в посочените точки за закотвяне.
Не превишавайте общата товароносимост и товароносимостта на рафт / 1U.
Най-тежките устройства инсталирайте най-надолу (първото долно U).
Разпределете натоварването равномерно; закрепете устройствата с монтажни винтове.
Преди преместване премахнете цялото оборудване и заключете вратите.
Използвайте само препоръчаните колела и крепежни елементи — проверете товароносимостта.
Заземете шкафа съгласно местните изисквания за заземяване на оборудване и метални обвивки.
Съхранявайте необходимите вентилационни разстояния — не блокирайте перфорациите.
Внимавайте за остри ръбове — препоръчват се предпазни ръкавици.
Периодични прегледи: проверявайте крепежите на всеки 12 месеца; проверявайте заземяването според местните изисквания.
Не използвайте на открито или в условия на висока влажност или корозивна среда.

HU Biztonsági utasítások:

Összeszerelés kizárólag legalább 2 személy által.
Rögzítse a szekrényt a padlóhoz vagy a falhoz a megjelölt rögzítési pontokon.
Ne lépje túl a teljes teherbírást és a polconkénti / 1U teherbírást.
A legnehezebb berendezéseket a legalacsonyabb pozíciókba szerelje (első alsó U).
Ossza el egyenletesen a terhelést; rögzítse a berendezést szerelvényis kímí csavarokkal.
Mozgatás előtt távolítsa el minden felszerelést és zárja le az ajtókat.
Használjon csak ajánlott görgőket és rögzítőelemeket — ellenőrizze a teherbírást.
Földelje a szekrényt a helyi földelési előírásoknak megfelelően.
Tartsa meg a szükséges szellőztőtávolságokat — ne takarja el a perforációkat.
Vigyázzon az éles élekre — védőkesztyű ajánlott.
Időszakos ellenőrzés: ellenőrizze a rögzítéseket 12 havonta; ellenőrizze a földelést a helyi előírásoknak megfelelően.
Ne használja kültéren vagy magas páratartalmú, korrozív környezetben.

RS Инструкције за безбедност:

Монтажа искључиво од стране најмање 2 особе.
Приклоните орман за под или зид на назначеним тачкама за учвршћивање.
Не прелазите укупни корисни терет нити терет по полици / 1U.
Најтежу опрему инсталирајте најниже (прво доње U).
Распоредите оптерећење равномерно; обезбедите опрему монтажним вијцима.
Пре премештања уклоните сву опрему и заључајте врата.
Користите само препоручена тачка и елементе за учвршћивање — проверите носивост.
Заземљите орман у складу са локалним захтевима за уземљење опреме и металних кућишта.
Одржавајте потребне вентилацијске размаке — не блокирајте перфорације.
Пазите на оштре ивице — препоручују се заштитне рукавице.
Периодични прегледи: проверите причвршћења на сваких 12 месеци; проверите уземљење према локалним захтевима.
Не користите напољу или у условима велике влажности или корозивног окружења.

RU Инструкция по безопасности:

Монтаж исключительно минимум двумя людьми.
Закрепите шкаф на полу или стене в указанных точках крепления.
Не превышайте общую грузоподъемность и грузоподъемность на полку / 1U.
Самое тяжелое оборудование устанавливайте внизу (первое нижнее U).
Равномерно распределяйте нагрузку; закрепляйте оборудование монтажными винтами.
Перед перемещением удалите все оборудование и заблокируйте двери.
Используйте только рекомендованные колесики и крепежные элементы — проверьте грузоподъемность.
Заземлите шкаф в соответствии с местными требованиями по заземлению оборудования и металлических корпусов.
Соблюдайте требуемые вентиляционные зазоры — не закрывайте перфорацию.
Осторожно: острые кромки — рекомендуется защитные перчатки.
Периодические осмотры: проверяйте крепления каждые 12 месяцев; проверяйте заземление согласно местным требованиям.
Не использовать на открытом воздухе или в условиях высокой влажности или коррозионной среды.

GR Οδηγίες ασφάλειας:

Εγκατάσταση μόνο από τουλάχιστον 2 άτομα.
Στερεώστε το ντουλάπι στο δάπεδο ή στον τοίχο στα καθορισμένα σημεία αγκύρωσης.
Μην υπερβείτε τη συνολική χωρητικότητα φορτίου ή το φορτίο ανά ράφι / 1U.
Εγκαταστήστε τον πιο βαρύ εξοπλισμό στις χαμηλότερες θέσεις (πρώτο κάτω U).
Καταβείτε το φορτίο ομοιόμορφα· ασφαλίστε τον εξοπλισμό με βίδες στήριξης.
Πριν από τη μετακίνηση, αφαιρέστε όλο τον εξοπλισμό και κλειδώστε τις πόρτες.
Χρησιμοποιήστε μόνο τους συνιστώμενους τροχούς και εξαρτήματα στερέωσης — ελέγξτε την αντοχή φόρτωσης.
Γειώστε το ντουλάπι σύμφωνα με τις τοπικές απαιτήσεις γείωσης για τον εξοπλισμό και τα μεταλλικά περιβλήματα.
Διατηρήστε τις απαιτούμενες αποστάσεις αερισμού — μην καλύπτετε τις οπές διάτρησης.
Προσοχή σε αιχμηρές ακμές — συνιστώνται προστατευτικά γάντια.
Περιοδικός έλεγχος: ελέγξτε τα στερεώματα κάθε 12 μήνες· επαληθεύστε τη γείωση σύμφωνα με τις τοπικές απαιτήσεις.
Μην το χρησιμοποιείτε σε υπαίθριους χώρους ή σε περιβάλλοντα υψηλής υγρασίας ή διαβρωτικά.









1. Assembly





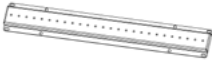
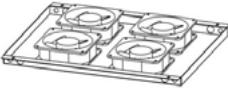

Be sure to strictly follow the instructions in this manual.







1.1 Preparations

Prepare the appropriate amount of free space on the surface on which the assembly will take place. Carefully remove all elements from the transport box. Further assembly instructions will be based on the diagram provided

1.1.1. Table of components

Cabinet items		
Item No.	Drawing	Supplied amount
Item A		1 pc.
Item B		1 pc.
Item C		2 pcs
Item D		2 pcs
Item E		1 pc.
Item F		1 pc.
Item G		15U~27U 4 pcs 32U~47U 6 pcs
Item H		1 pc.
Item I		4 pcs
Item J		3 pcs 4 pcs

Item K		4 pcs
Item L		4 pcs
Item M		15U~27U 8 pcs 32U~47U 12 pcs
Item N		1 pc.
Item O		3 pcs
Item W		4 pcs

Screws			
Item No.	Drawing	Supplied amount	
Item Q		17 pcs	
Item R		15U~27U	38 pcs
		32U~47U	54 pcs
Item S		15U~27U	24 pcs
		32U~47U	28 pcs
Item R2		15U~27U	18 pcs
		32U~47U	26 pcs
Item V		20 pcs	
Item V2		17 pcs	

2. Installation steps

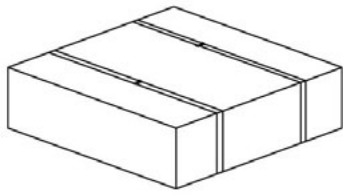

TOP & BOTTOM PACKAGE 1/3

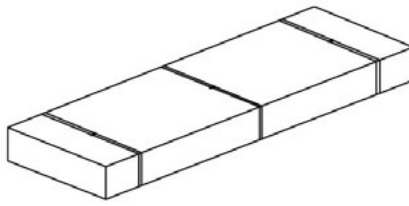

FRONT, REAR & SIDE DOORS
PACKAGE 2/3

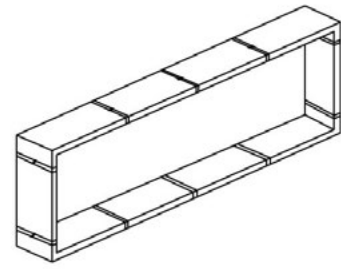

FRAME PACKAGE 3/3

Step 1. Remove the front door lock (item N), the side panel locks and the rear panel lock (item O), the components are in pack 1/3. Then remove the front glass door (item A), back panel (item B) and side panels (item C) from pack 2/3. At this stage we start by fitting locks to the above components.

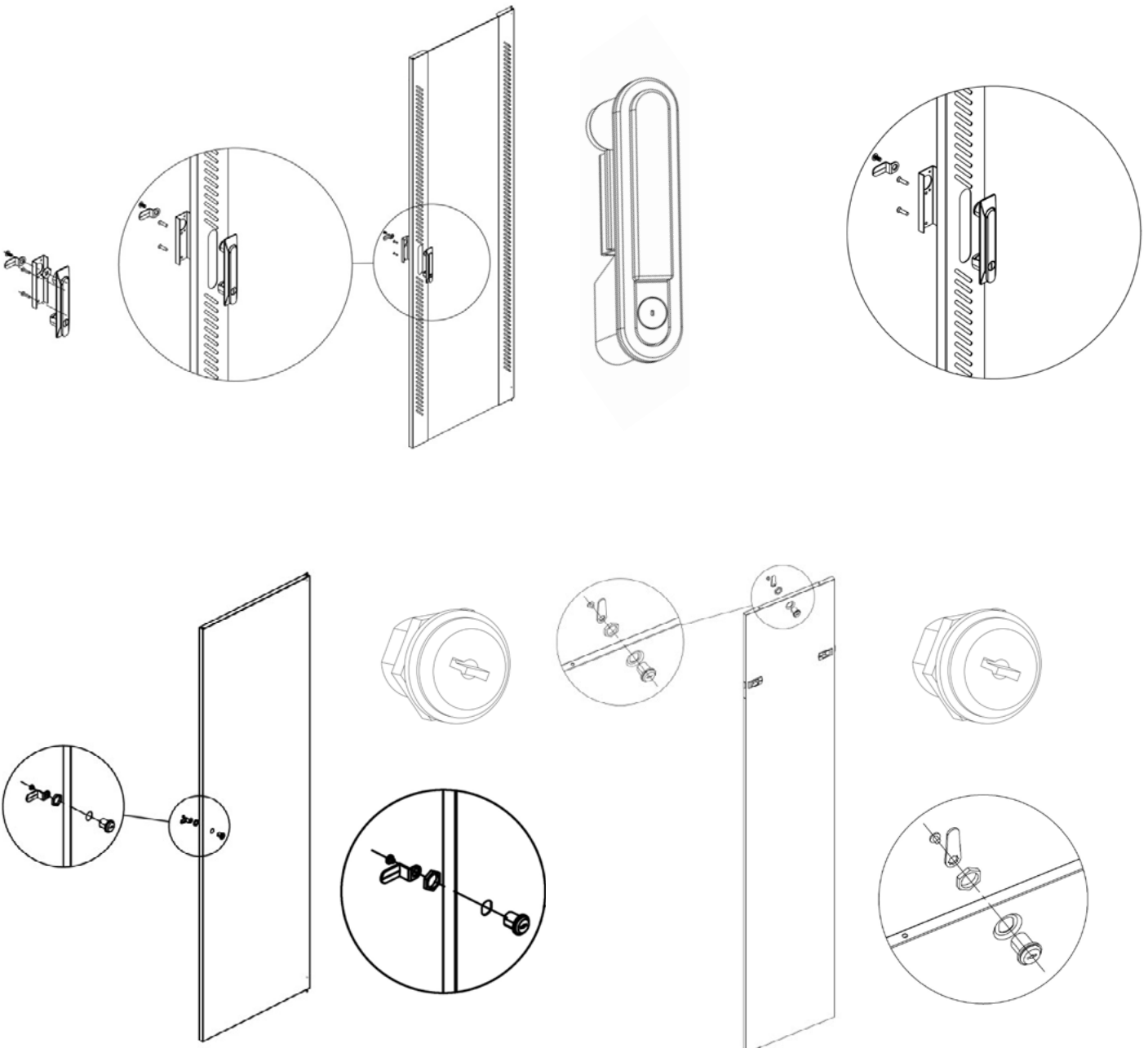

Step 2. Unpack the frame parts (item D) from the 3/3 package. Then arrange the frames parallel to each other, with the square holes facing inward. You can identify the bottom part of the frame by the ground mounting pieces.

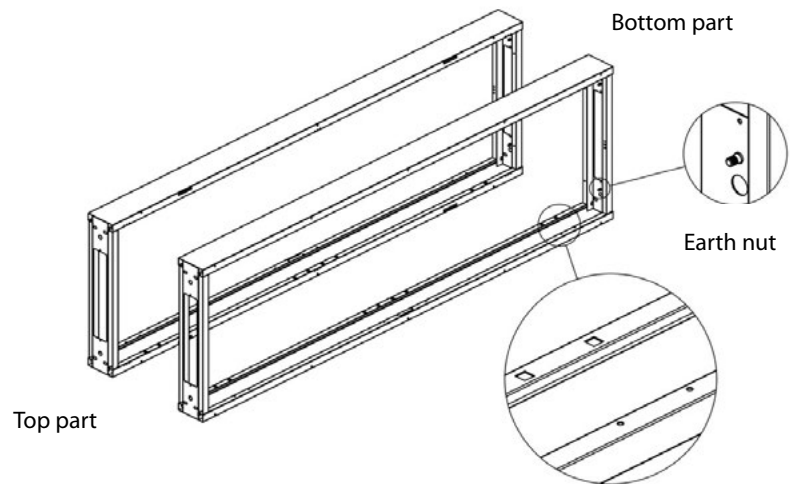

Step 3. Fit the top cover (item E) to the upper parts of the frame (item D), and then connect them with an M8 allen screw (item Q).

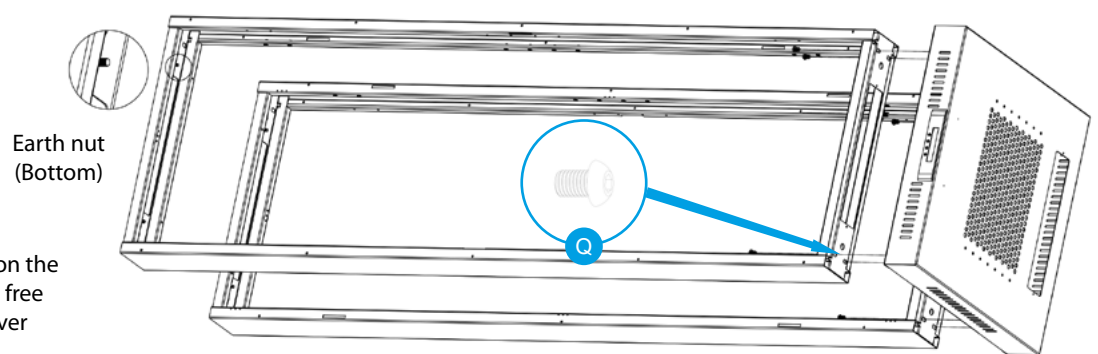

Note: Frames should be mounted on the cover in such a way that there is no free gap between the frame and the cover from the inside.

Step 4. Place the lower cover (item F) on the lower part of the frame (item D) and use the M8 Allen screw (item Q) to connect them.

Note: Frames should be mounted on the cover in such a way that there is no free gap between the frame and the cover from the inside.

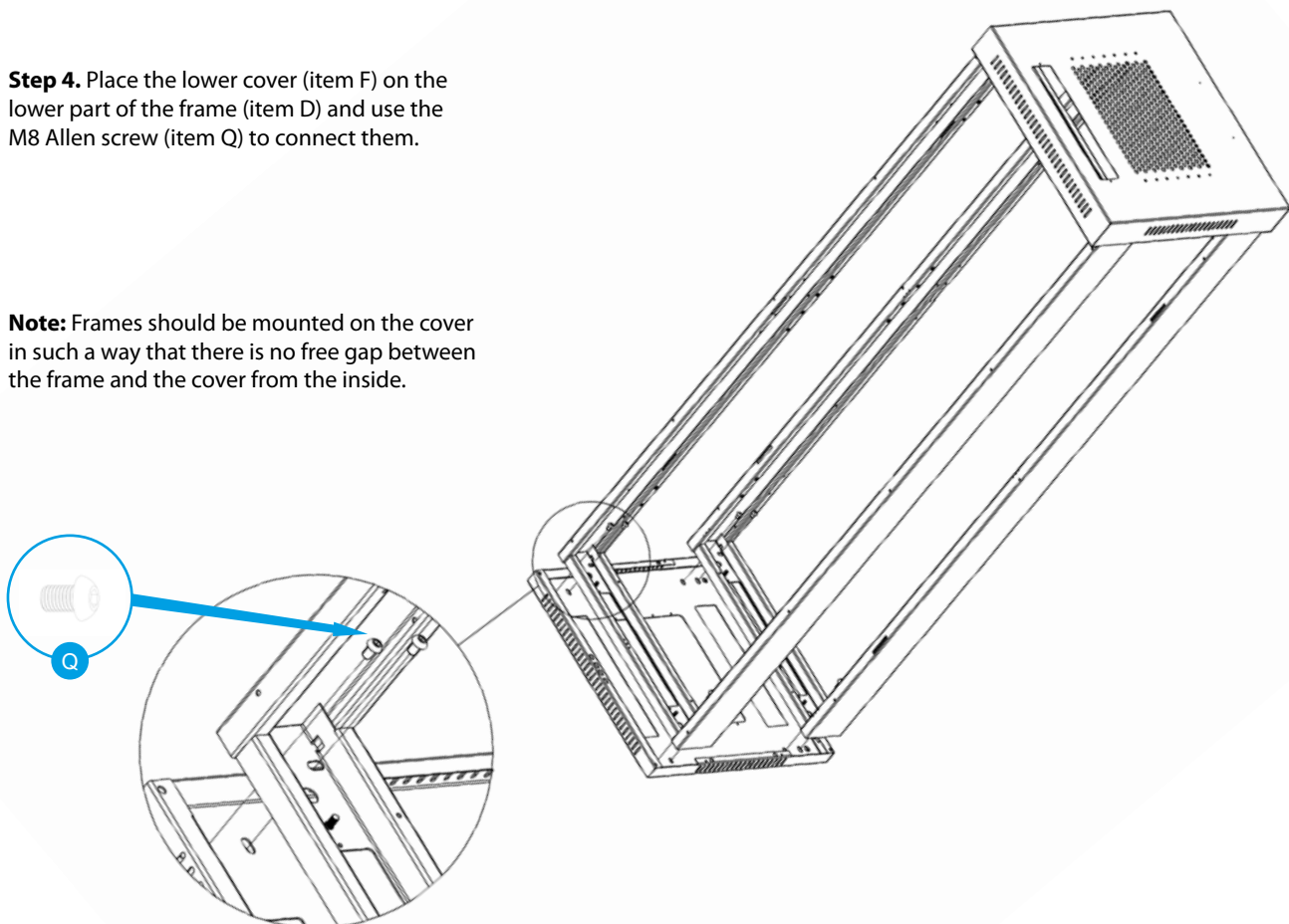

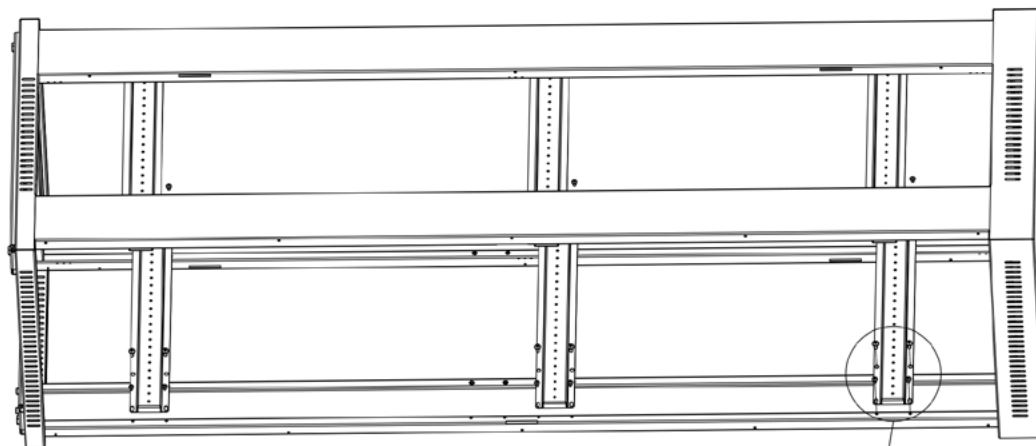

Step 5. Place the crossbar (item G) on the frame (item D), avoiding the hole intended for the lock. Use an M5*10 screw (item R2) and an M5 self-tapping screw (item R) to secure the crossbar.

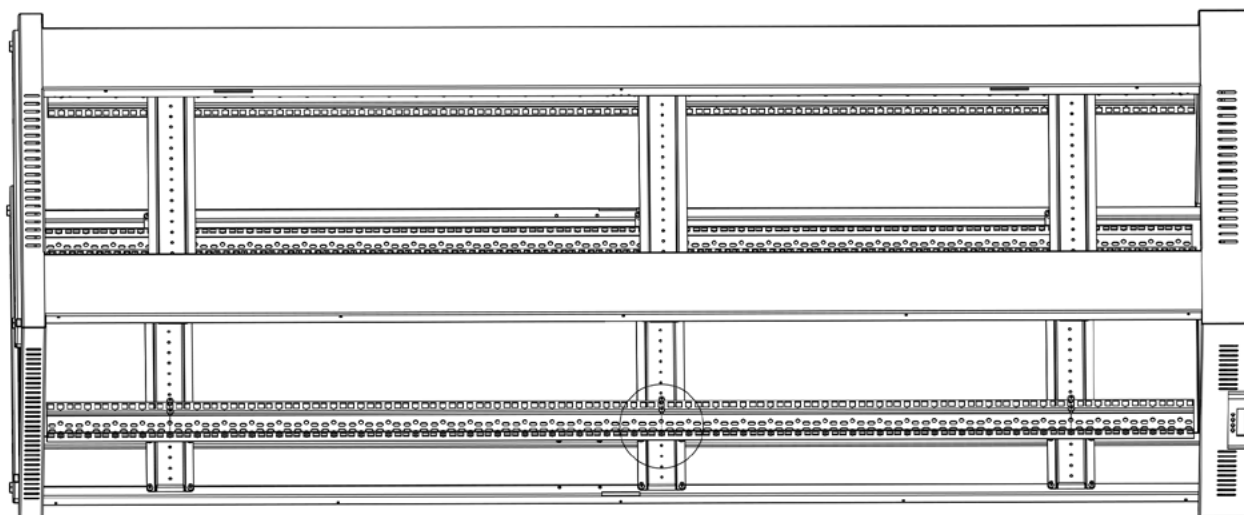
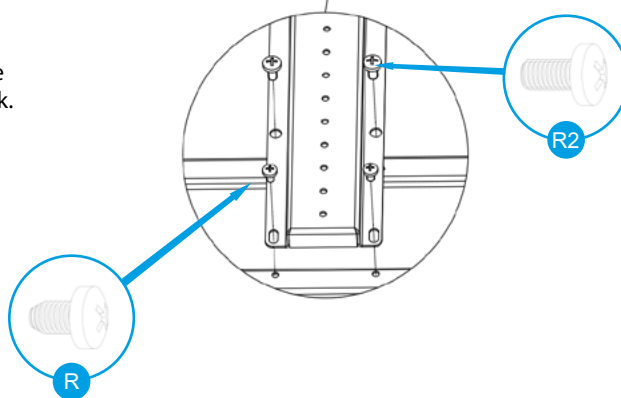

Step 6. Prepare a M5*10 self-tapping screw (item R) to attach the vertical mounting rails (item I) to the horizontal crossbars (item G).

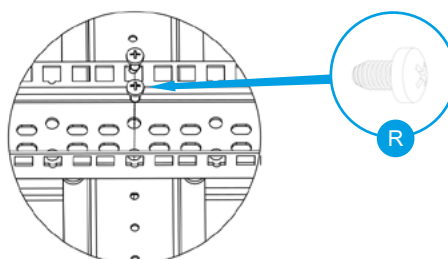

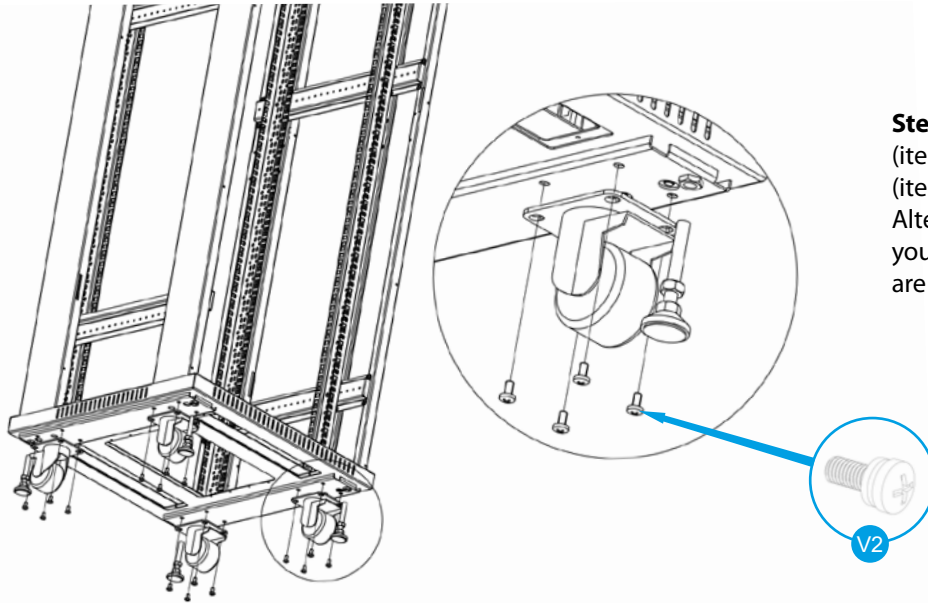

Step 7. Prepare screws with a washer (item V2) to attach the four casters (item L) to the bottom cover (item F). Alternatively, instead of the casters, you can attach the feet (item K), which are included in the kit, to the lid.

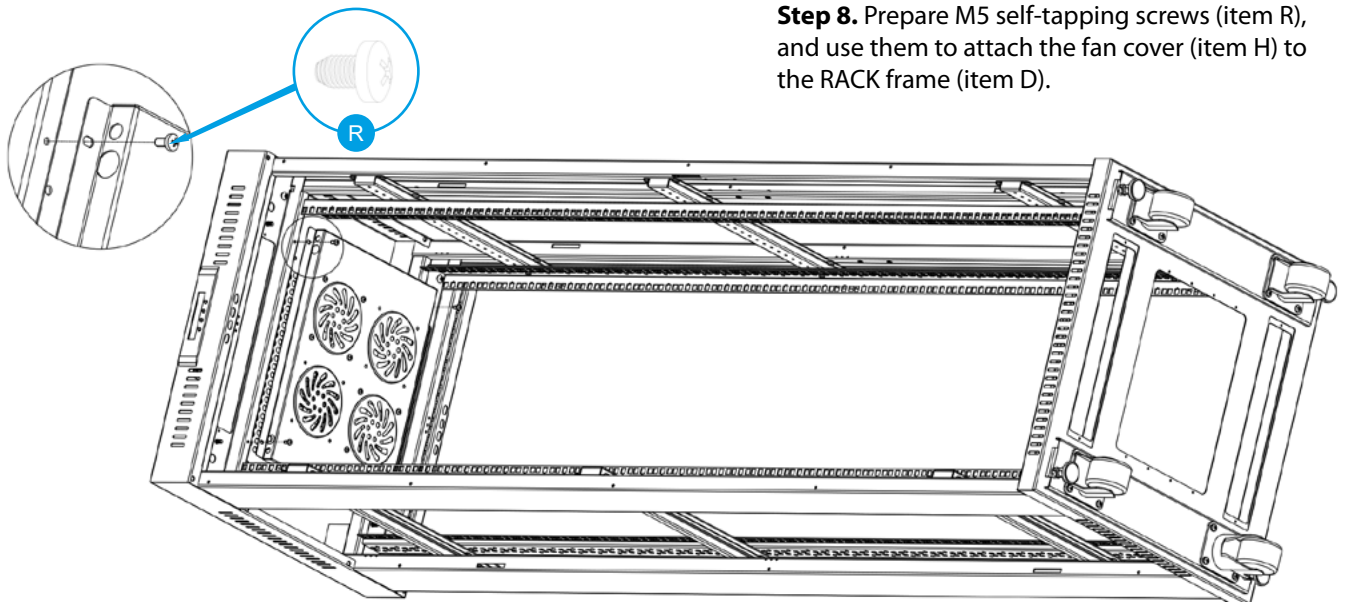

Step 8. Prepare M5 self-tapping screws (item R), and use them to attach the fan cover (item H) to the RACK frame (item D).

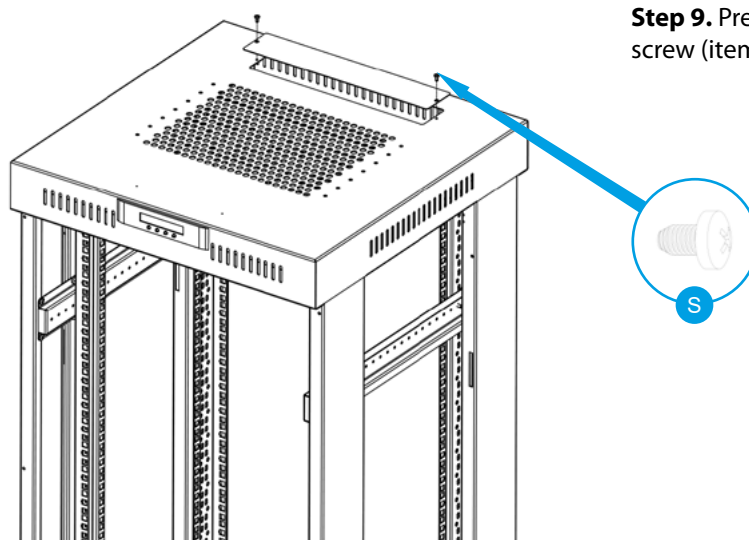

Step 9. Prepare and use an M4 self-tapping screw (item S) to fix the top panel cap (item J).

Step 10. Prepare and use M4 self-tapping screws (item S) to fix the door stops (item M), 12U~27U (8pcs), 32U~47U (12pcs).

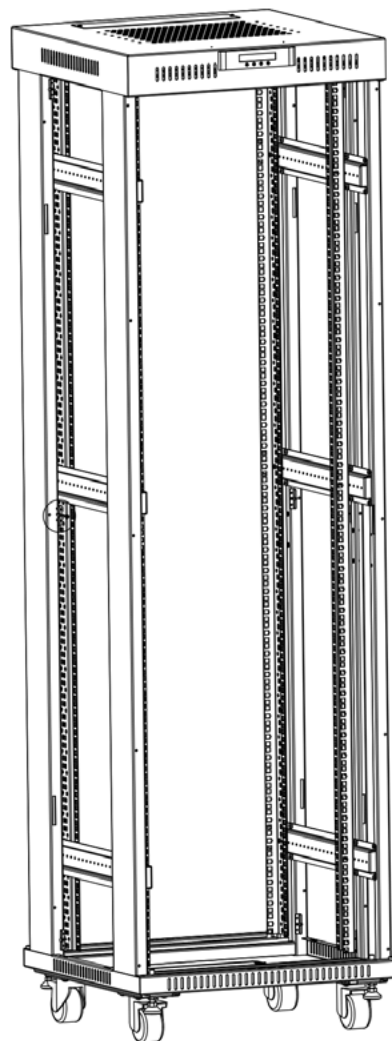

Step 11. Prepare and place the door spacers (item W) for the front door and rear panel (items A and B) in the appropriate places. Fit the side panels (item C) at the very end.

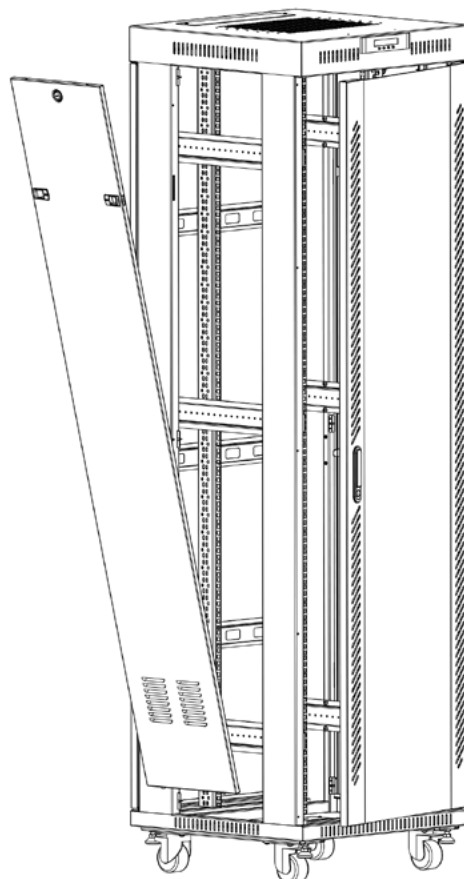
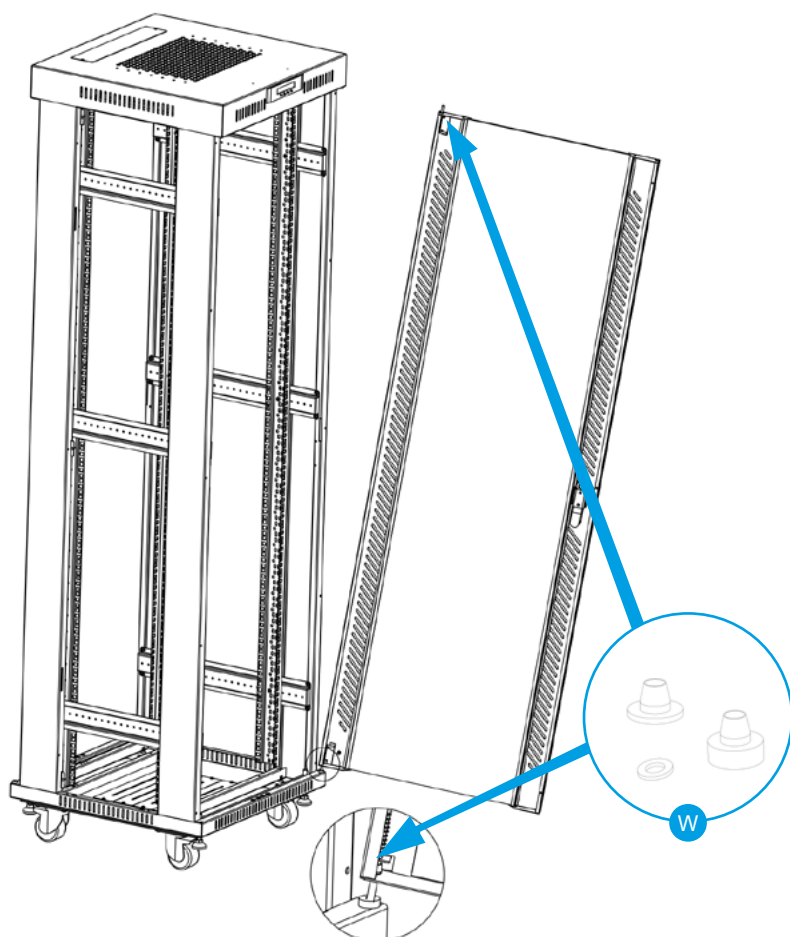







1. Assemblage





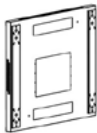
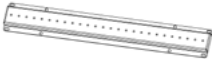
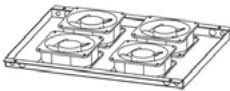

Veillez à respecter strictement les instructions de ce manuel.







1.1 Préparatifs

Préparez suffisamment d'espace libre sur la surface sur laquelle le montage sera effectué. Retirez soigneusement tous les éléments de la boîte de transport. Les étapes de montage suivantes se baseront sur le schéma fourni

1.1.1. Tableau des composants

Éléments de l'armoire		
N° d'article	Dessin	Quantité fournie
A		1
B		1
C		2
D		2
E		1
F		1
G		15U~27U 4 32U~47U 6
H		1
I		4
J		3 4

K		4
L		4
M		15U~27U 8 32U~47U 12
N		1
O		3
W		4

Vis			
N° d'article	Dessin	Quantité fournie	
Q		17	
R		15U~27U	38
		32U~47U	54
S		15U~27U	24
		32U~47U	28
R2		15U~27U	18
		32U~47U	26
V		20	
V2		17	

2. Étapes d'installation

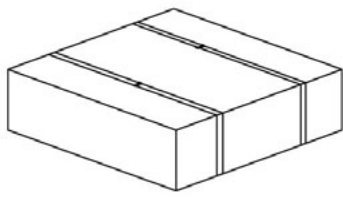

HAUT ET BAS - COLIS 1/3

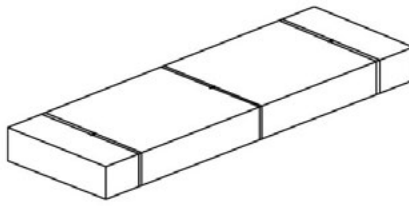

PORTES AVANT, ARRIÈRE ET
LATÉRALES - COLIS 2/3

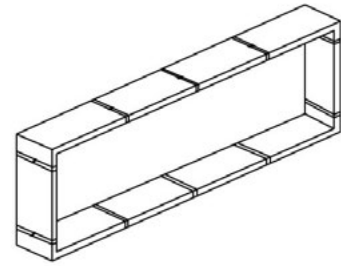

CADRE - COLIS 3/3

Étape 1. Retirez la serrure de la porte avant (N), les serrures des panneaux latéraux et la serrure du panneau arrière (O); les composants se trouvent dans le colis 1/3. Retirez ensuite la porte avant en verre (A), le panneau arrière (B) et les panneaux latéraux (C) du colis 2/3. À cette étape, nous commençons par monter les serrures sur les composants ci-dessus.

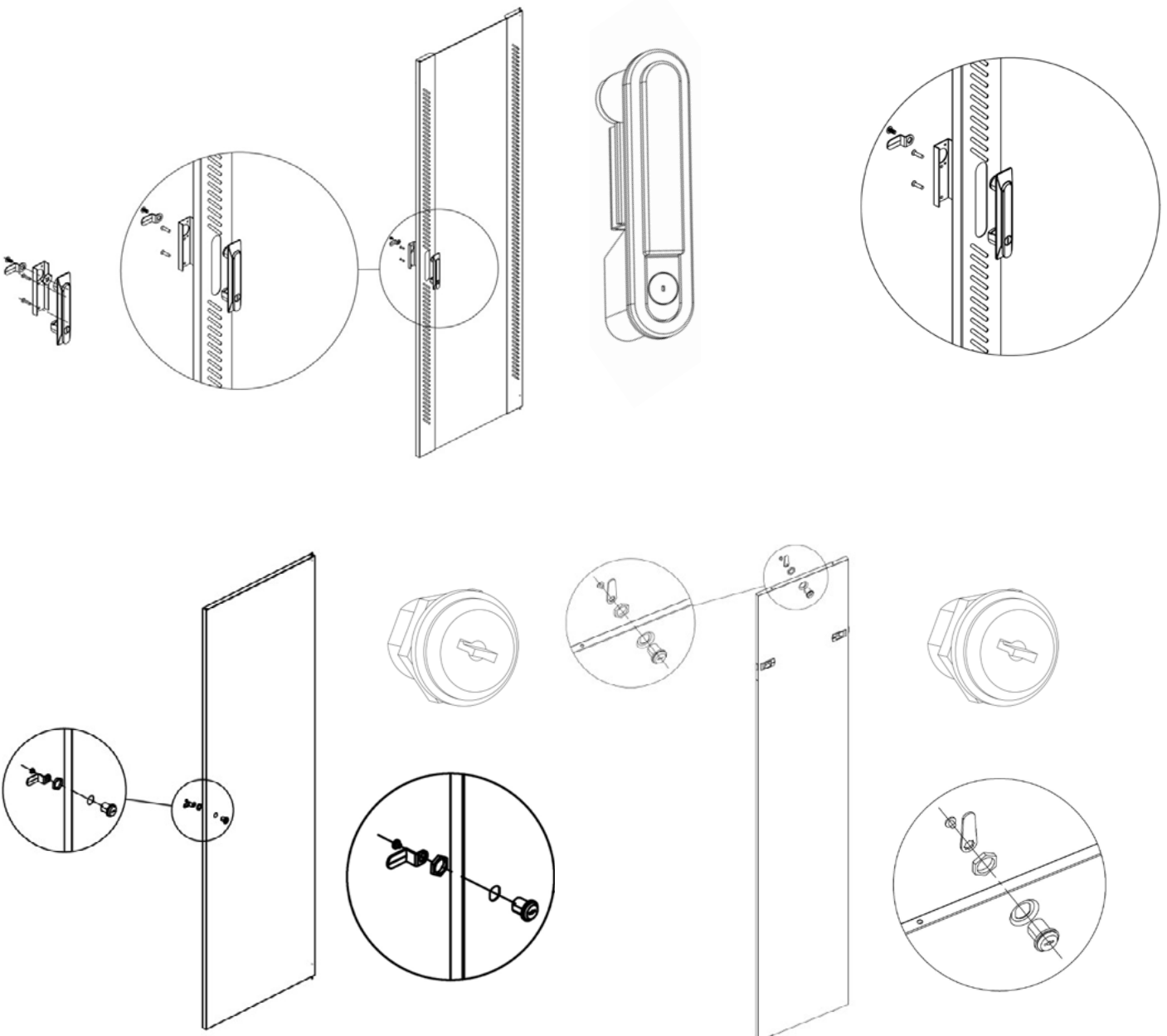

Étape 2. Déballez les éléments du cadre (D) du colis 3/3. Disposez ensuite les cadres parallèlement l'un à l'autre, avec les trous carrés orientés vers l'intérieur. Vous pouvez reconnaître la partie inférieure du cadre grâce aux éléments de mise à la terre.

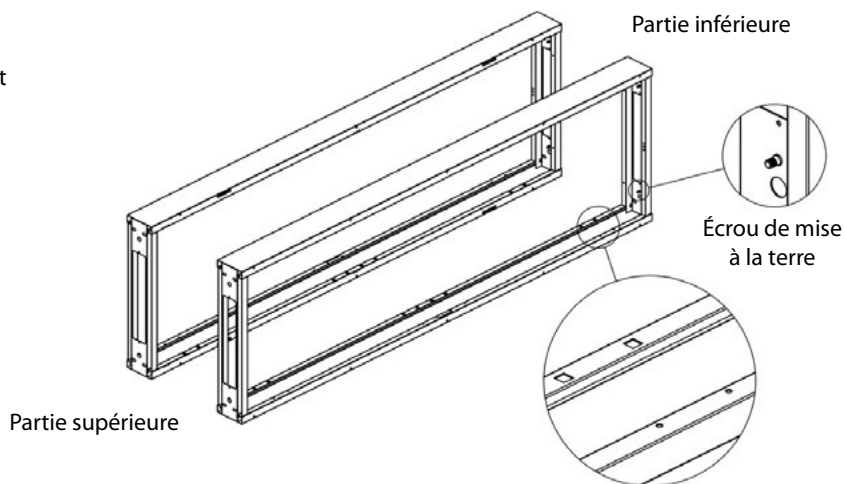

Étape 3. Fixez le panneau supérieur (E) aux parties supérieures du cadre (D), puis reliez-les à l'aide d'une vis Allen M8 (Q).

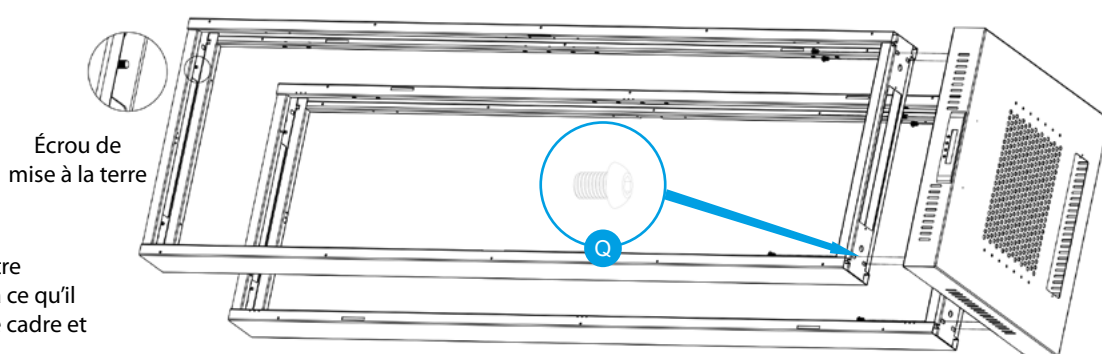

Remarque: Les cadres doivent être montés sur le capot de manière à ce qu'il n'y ait aucun espace libre entre le cadre et le capot du côté intérieur.

Étape 4. Placez le panneau inférieur (F) sur la partie inférieure du cadre (D) et utilisez la vis Allen M8 (Q) pour les relier.

Remarque: Les cadres doivent être montés sur le capot de manière à ce qu'il n'y ait aucun espace libre entre le cadre et le capot du côté intérieur.

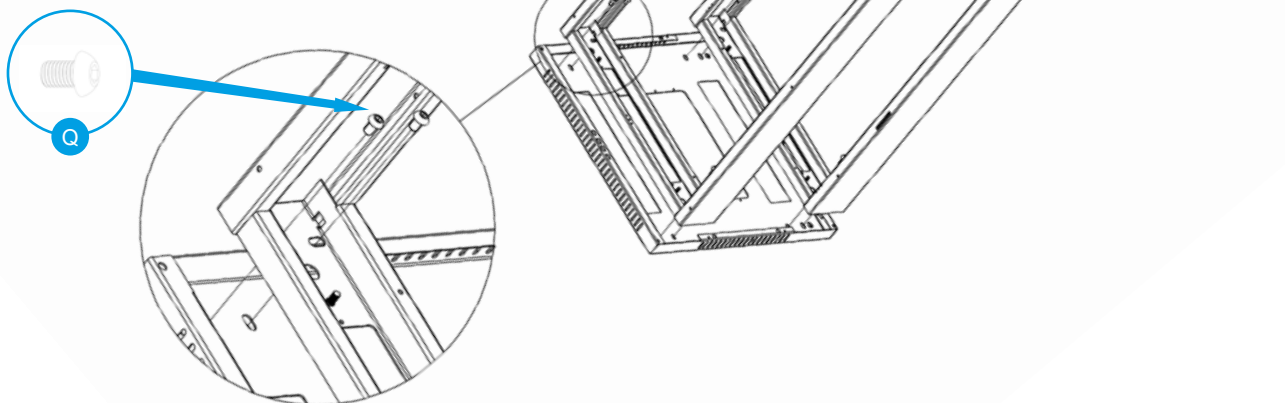

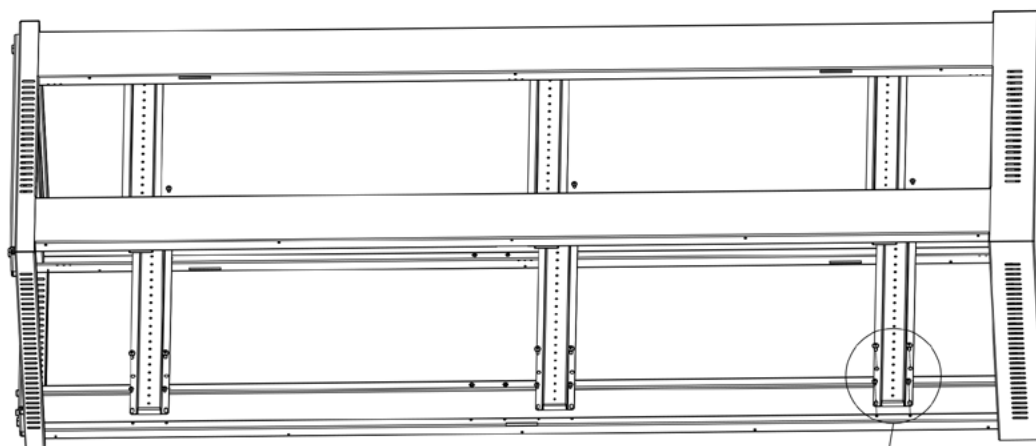

Étape 5. Placez la traverse (G) sur le cadre (D) en évitant le trou destiné à la serrure. Utilisez une vis M5*10 (R2) et une vis autotaraudeuse M5 (R) pour fixer la traverse.

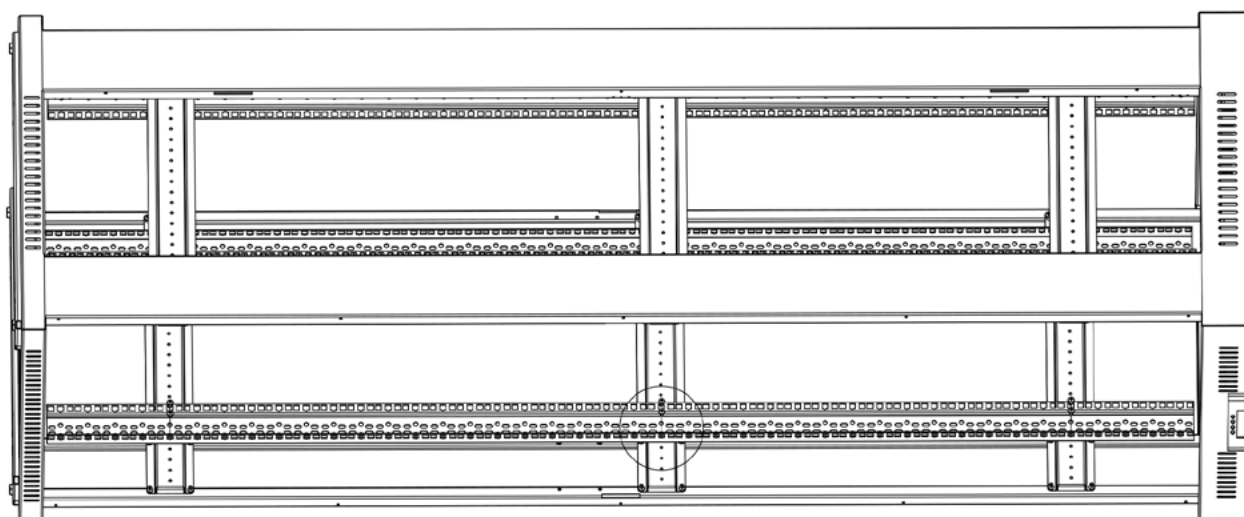
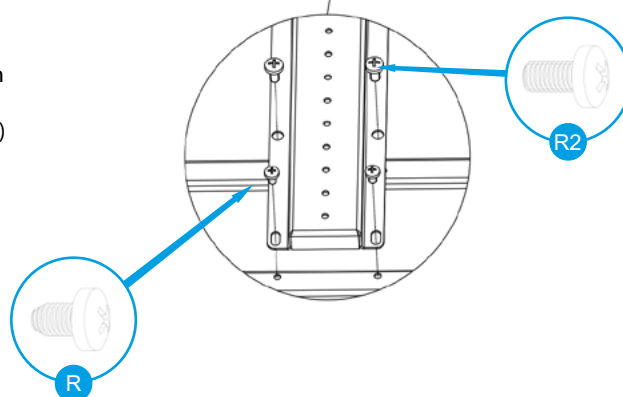

Étape 6. Préparez une vis autotaraudeuse M5*10 (R) pour fixer les rails de montage verticaux (I) aux traverses horizontales (G).

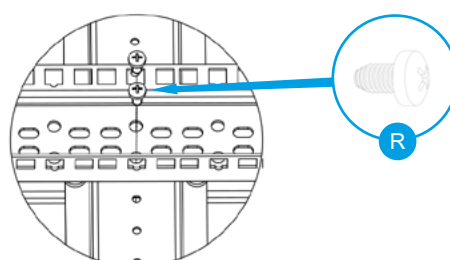

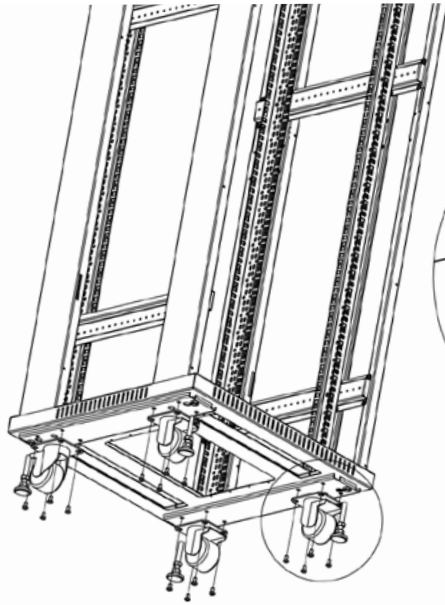

Étape 7. Préparez des vis avec rondelle (item V2) pour fixer les quatre roulettes (L) au panneau inférieur (F). À la place des roulettes, vous pouvez également fixer au capot les pieds (K) inclus dans le kit.

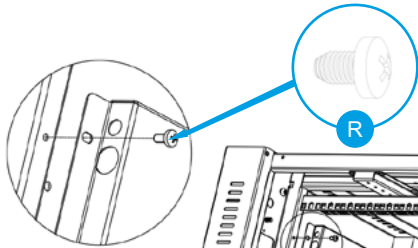
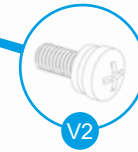
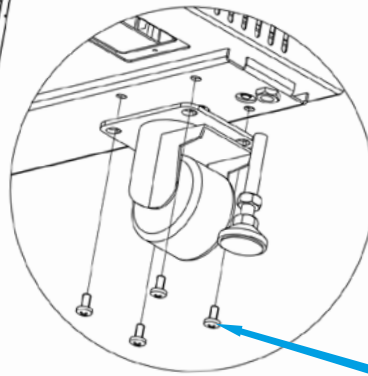

Étape 8. Préparez des vis autotaraudeuses M5 (R) et utilisez-les pour fixer le cache du ventilateur (H) au cadre RACK (D).

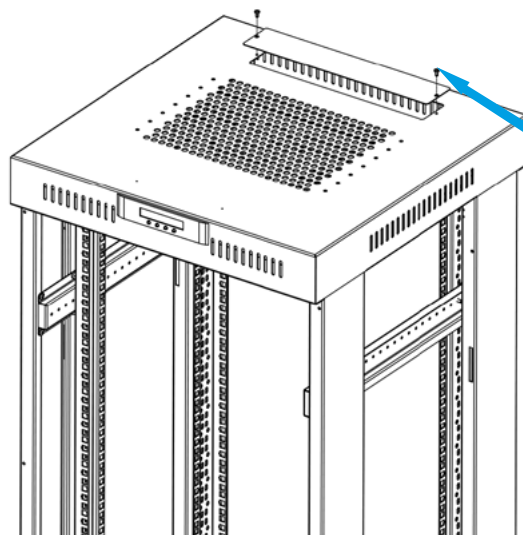
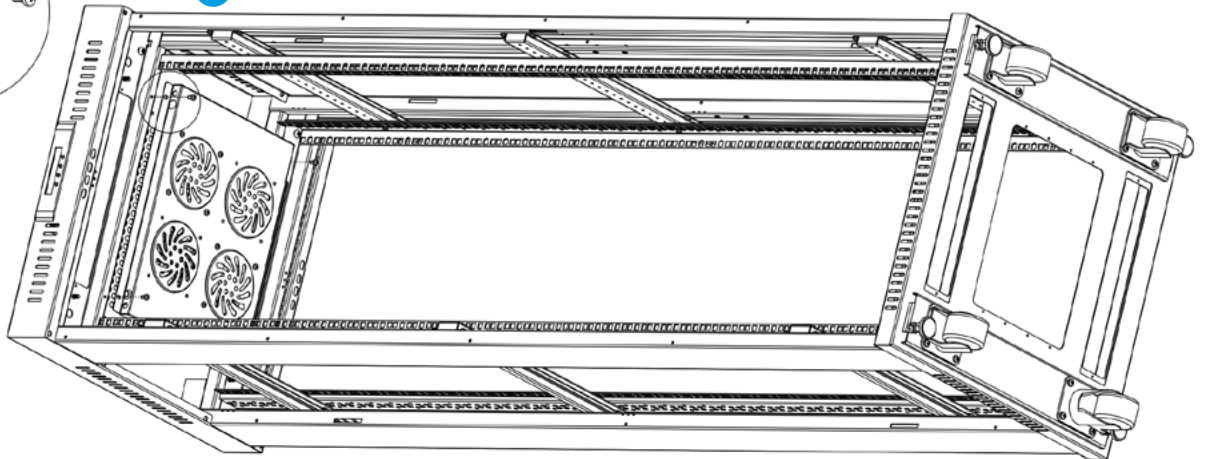

Étape 9. Préparez et utilisez une vis autotaraudeuse M4 (S) pour fixer le cache du panneau supérieur (J).

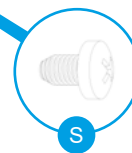

Étape 10. Préparez et utilisez des vis autotaraudeuses M4 (S) pour fixer les butées de porte (M), 12U~27U (8), 32U~47U (12).

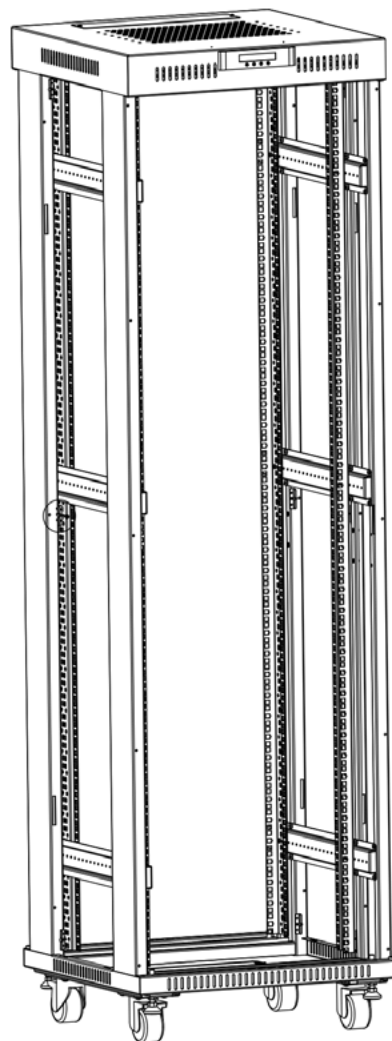
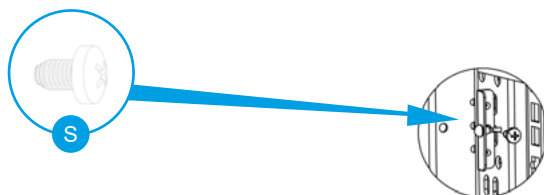

Étape 11. Préparez et placez les entretoises de porte (W) pour la porte avant et le panneau arrière (items A et B) aux emplacements appropriés. Montez les panneaux latéraux (C) tout à la fin.

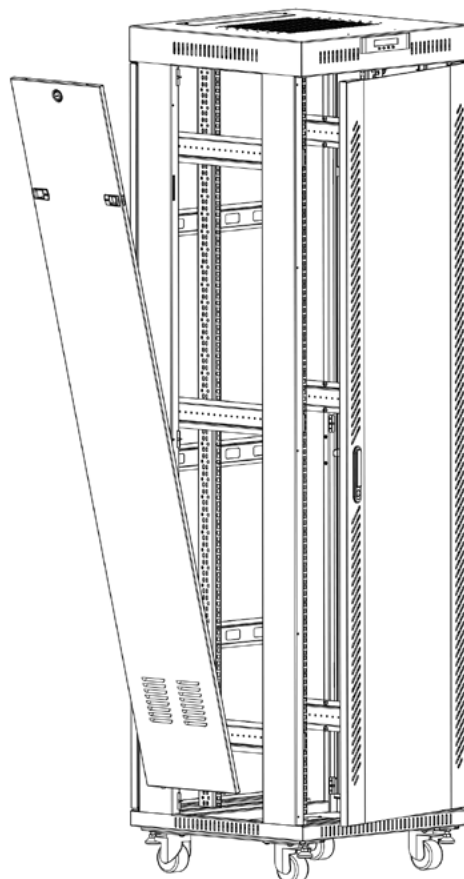
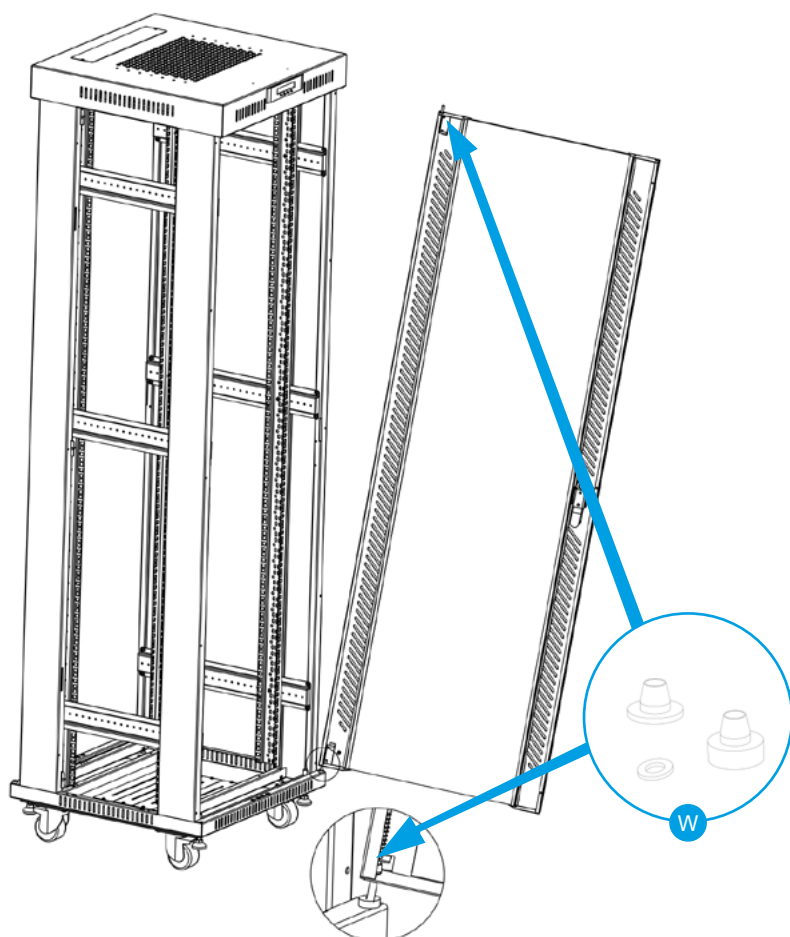









1. Montaje





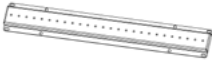
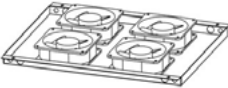

Asegúrese de seguir estrictamente las instrucciones de este manual.







1.1 Preparativos

Prepare la cantidad adecuada de espacio libre en la superficie sobre la que se realizará el montaje. Retire cuidadosamente todos los elementos de la caja de transporte. Las siguientes instrucciones de montaje se basarán en el diagrama proporcionado

1.1.1. Tabla de componentes

Elementos del armario		
N.º de artículo	Dibujo	Cantidad suministrada
A		1
B		1
C		2
D		2
E		1
F		1
G		15U~27U 4 32U~47U 6
H		1
I		4
J		3 4

K		4
L		4
M		15U~27U 8 32U~47U 12
N		1
O		3
W		4

Tornillos			
N.º de artículo	Dibujo	Cantidad suministrada	
Q		17	
R		15U~27U	38
		32U~47U	54
S		15U~27U	24
		32U~47U	28
R2		15U~27U	18
		32U~47U	26
V		20	
V2		17	

2. Pasos de instalación

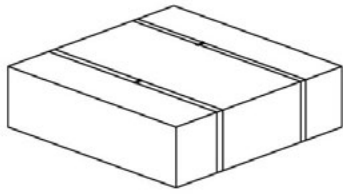

**SUPERIOR E INFERIOR -
PAQUETE 1/3**

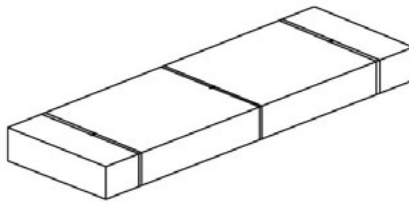

**PUERTAS FRONTAL, TRASERA Y
LATERALES - PAQUETE 2/3**

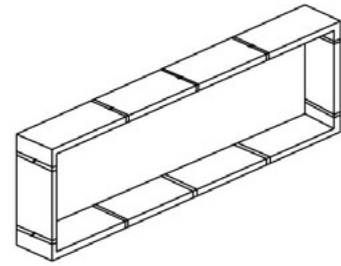

BASTIDOR - PAQUETE 3/3

Paso 1. Retire la cerradura de la puerta frontal (N), las cerraduras de los paneles laterales y la cerradura del panel trasero (O); los componentes se encuentran en el paquete 1/3. A continuación, retire la puerta frontal de vidrio (A), el panel trasero (B) y los paneles laterales (C) del paquete 2/3. En esta etapa comenzamos montando las cerraduras en los componentes mencionados.

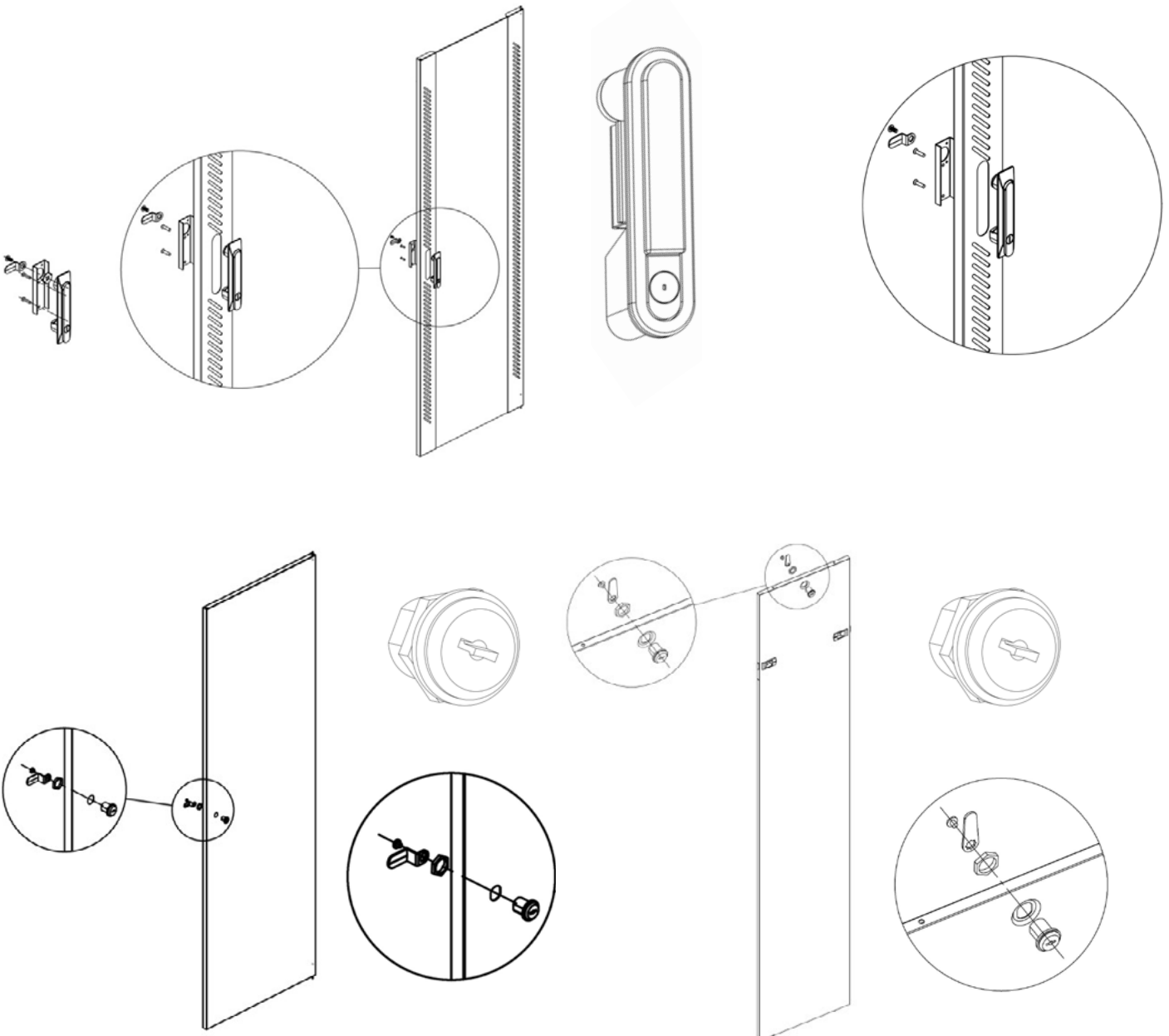

Paso 2. Desembale las partes del bastidor (D) del paquete 3/3. Luego coloque los bastidores paralelos entre sí, con los orificios cuadrados orientados hacia el interior. Puede identificar la parte inferior del bastidor por las piezas de puesta a tierra.

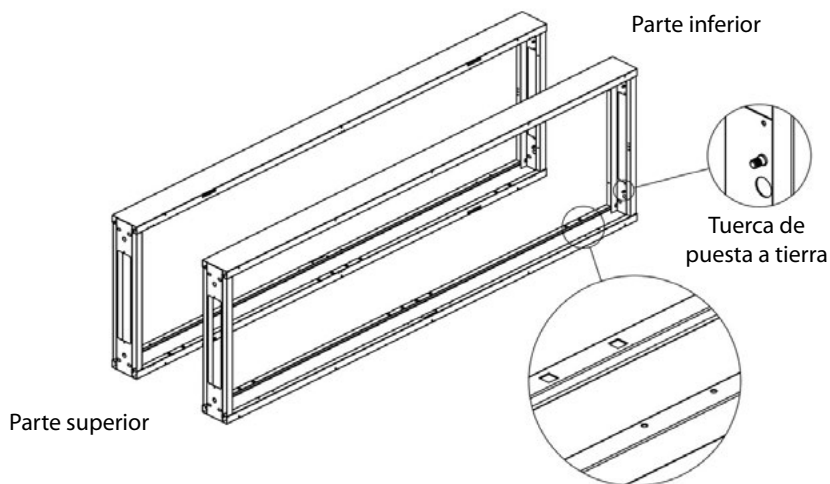

Paso 3. Monte la cubierta superior (E) en las partes superiores del bastidor (D) y luego únalas con un tornillo Allen M8 (Q).

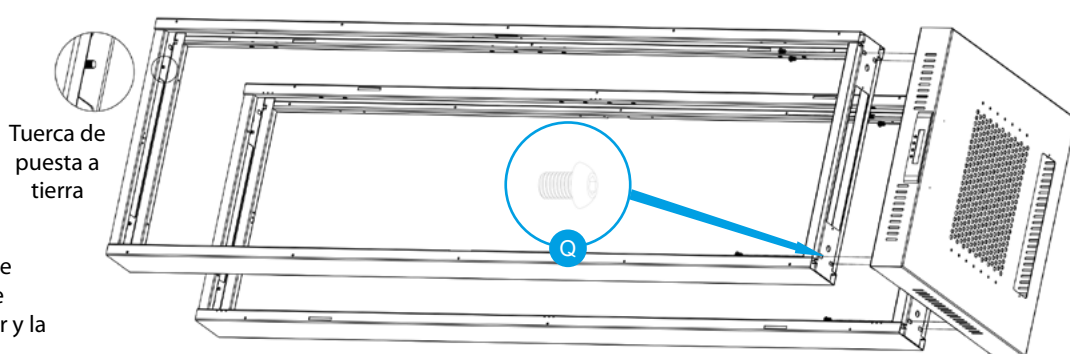

Nota: Los bastidores deben montarse sobre la tapa de modo que no quede ningún espacio libre entre el bastidor y la tapa por la parte interior.

Paso 4. Coloque la cubierta inferior (F) en la parte inferior del bastidor (D) y utilice el tornillo Allen M8 (Q) para unirlos.

Nota: Los bastidores deben montarse sobre la tapa de modo que no quede ningún espacio libre entre el bastidor y la tapa por la parte interior.

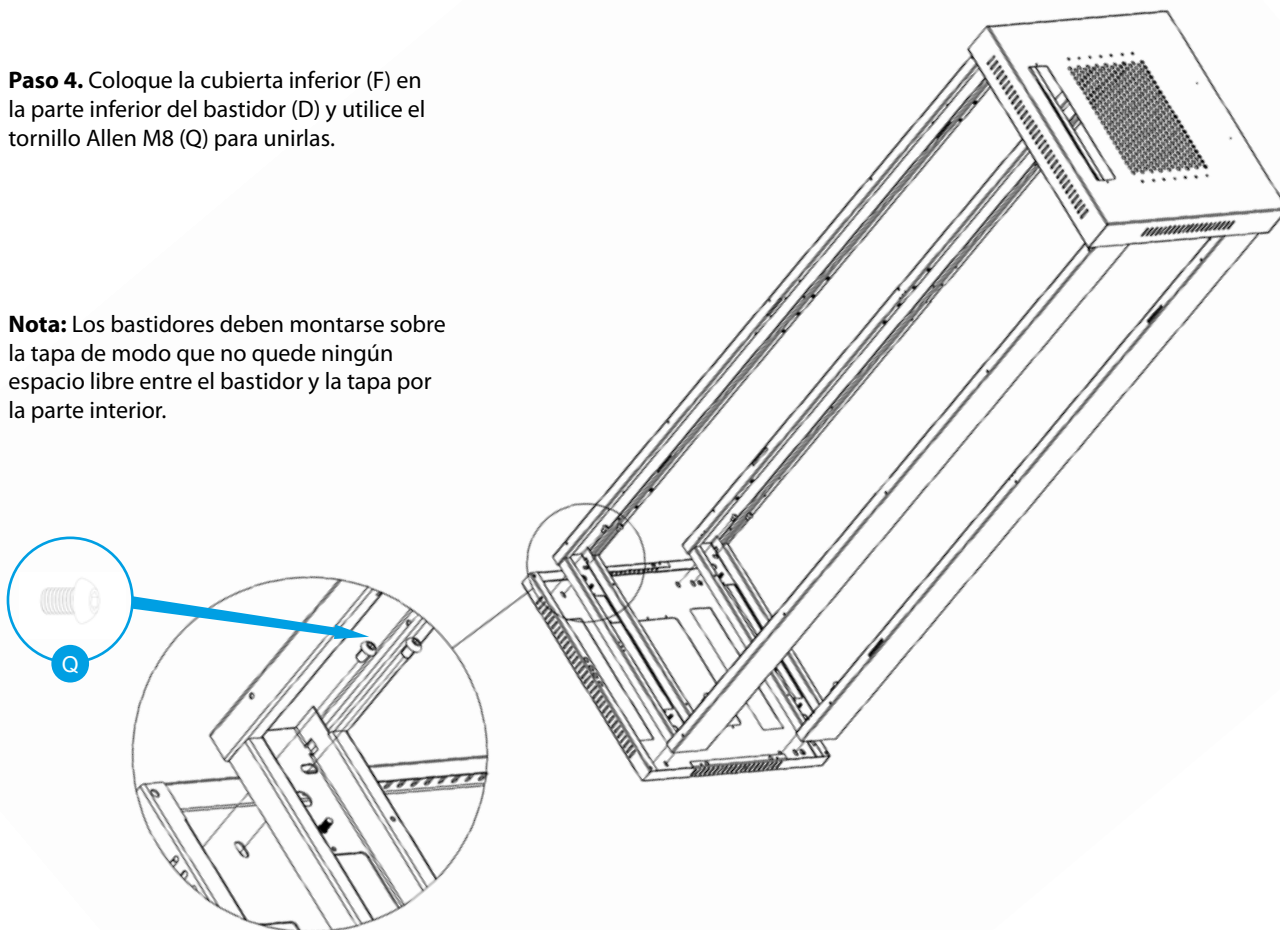

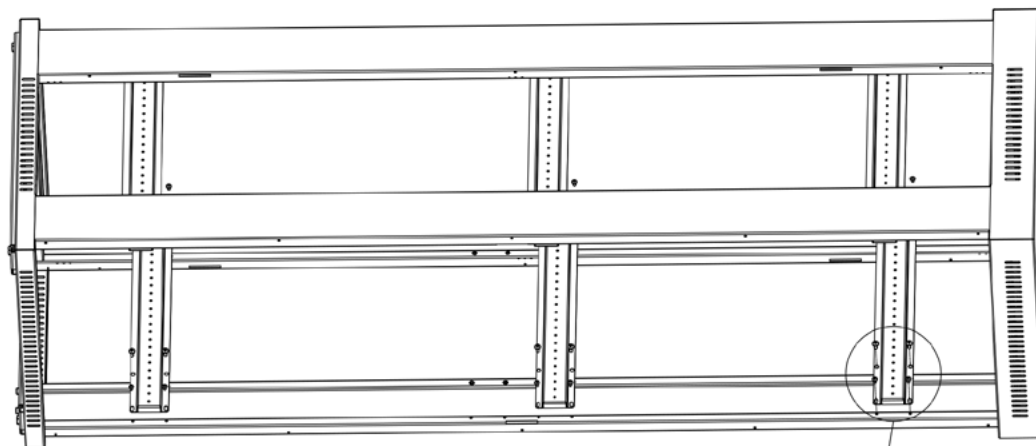

Paso 5. Coloque el travesaño (G) sobre el bastidor (D), evitando el orificio destinado a la cerradura. Utilice un tornillo M5*10 (R2) y un tornillo autorroscante M5 (R) para fijar el travesaño.

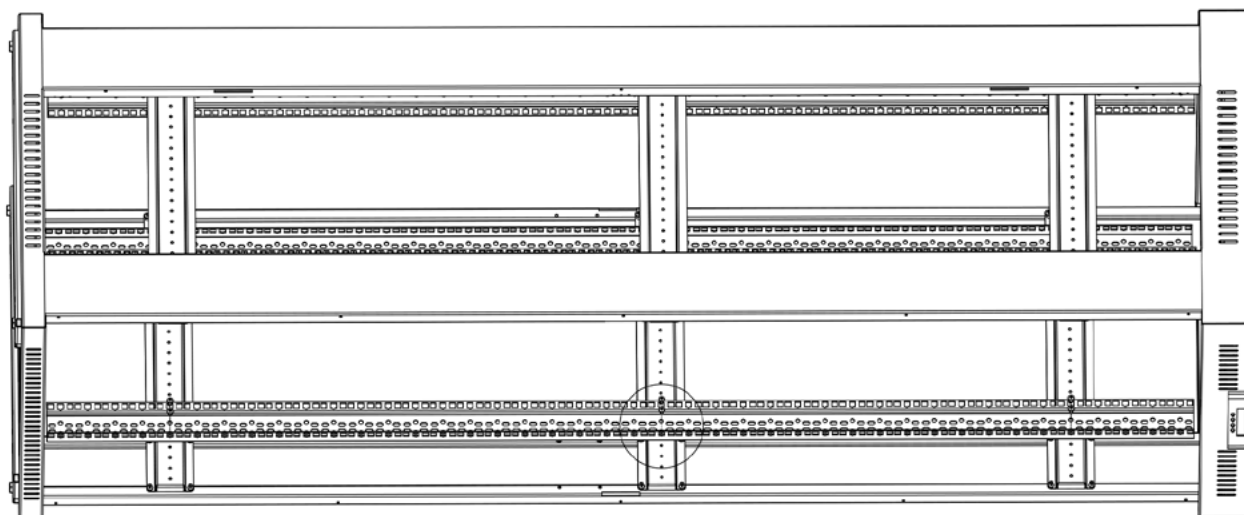
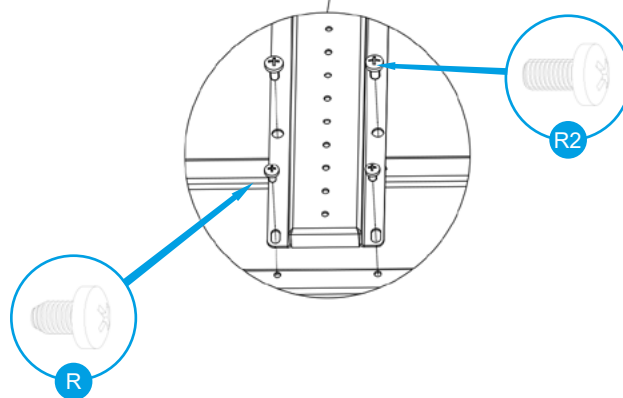

Paso 6. Prepare un tornillo autorroscante M5*10 (R) para fijar los carriles de montaje verticales (I) a los travesaños horizontales (G).

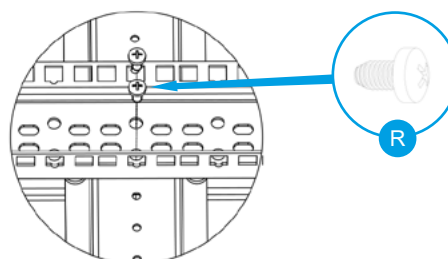

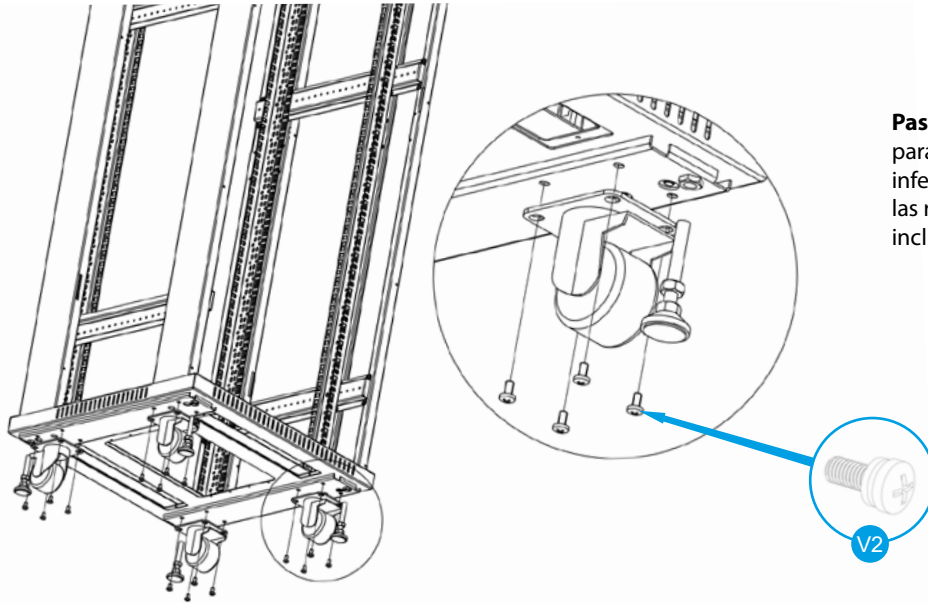

Paso 7. Prepare tornillos con arandela (V2) para fijar las cuatro ruedas (L) a la cubierta inferior (F). Alternativamente, en lugar de las ruedas, puede fijar a la tapa las patas (K) incluidas en el kit.

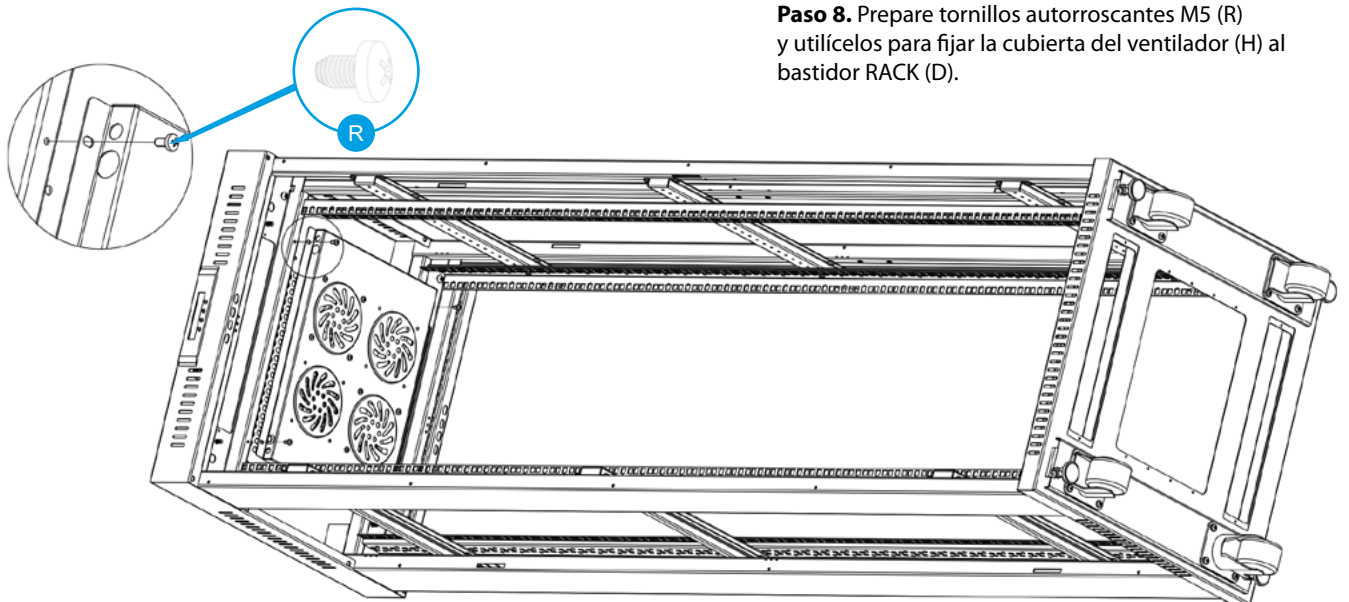

Paso 8. Prepare tornillos autorroscantes M5 (R) y utilícelos para fijar la cubierta del ventilador (H) al bastidor RACK (D).

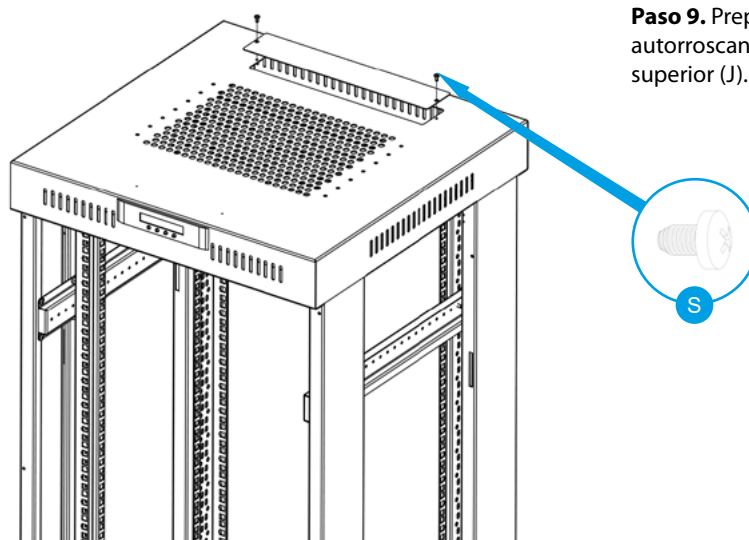

Paso 9. Prepare y utilice un tornillo autorroscante M4 (S) para fijar la tapa del panel superior (J).

Paso 10. Prepare y utilice tornillos autorroscantes M4 (S) para fijar los topos de puerta (M), 12U~27U (8), 32U~47U (12)

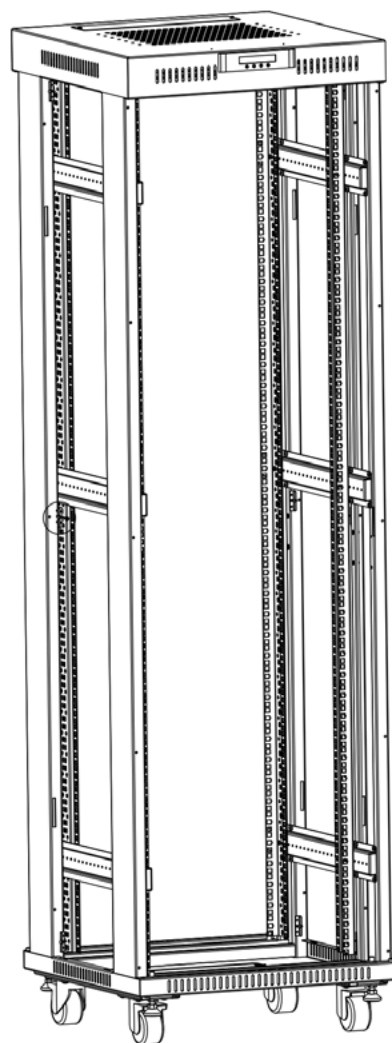

Paso 11. Prepare y coloque los separadores de puerta (W) para la puerta frontal y el panel trasero (ítems A y B) en los lugares adecuados. Monte los paneles laterales (C) al final.

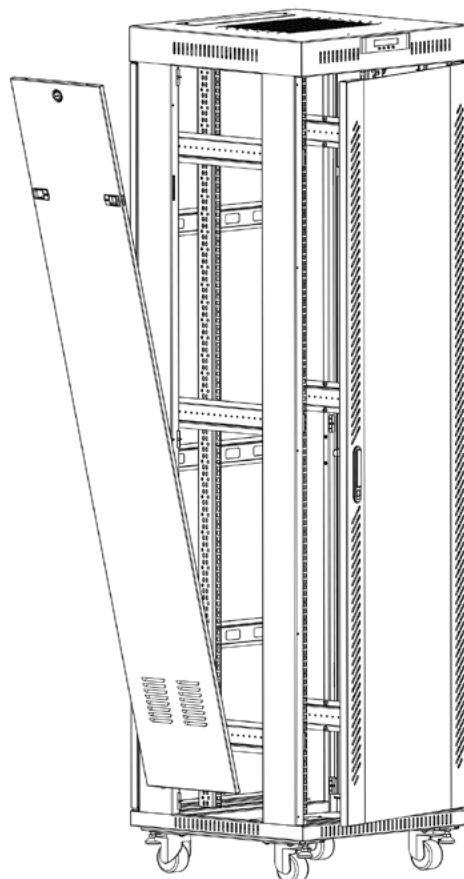
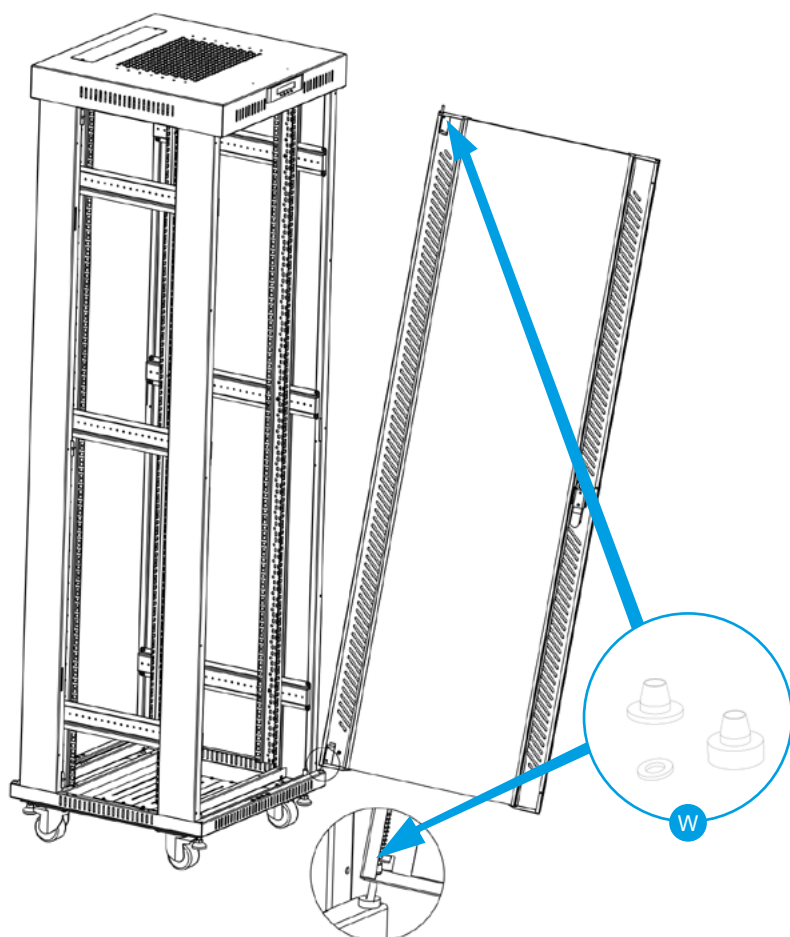









1. Montagem





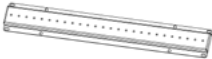
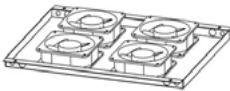

Certifique-se de seguir rigorosamente as instruções deste manual.





1.1 Preparação

Prepare espaço livre suficiente na superfície onde a montagem será realizada. Retire cuidadosamente todos os elementos da caixa de transporte. As instruções de montagem seguintes terão por base o diagrama fornecido

1.1.1. Tabela de componentes

Itens do armário		
N.º do item	Desenho	Quantidade fornecida
A		1
B		1
C		2
D		2
E		1
F		1
G		15U~27U 4 32U~47U 6
H		1
I		4
J		3 4

K		4
L		4
M		15U~27U 8 32U~47U 12
N		1
O		3
W		4

Parafusos			
N.º do item	Desenho	Quantidade fornecida	
Q		17	
R		15U~27U	38
		32U~47U	54
S		15U~27U	24
		32U~47U	28
R2		15U~27U	18
		32U~47U	26
V		20	
V2		17	

2. Etapas de instalação

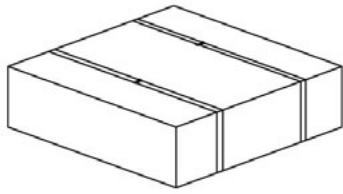

TOPO E BASE - EMBALAGEM
1/3

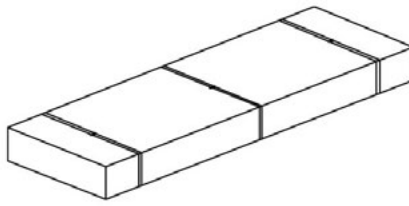

PORTAS FRONTAL, TRASEIRA E
LATERAIS - EMBALAGEM 2/3

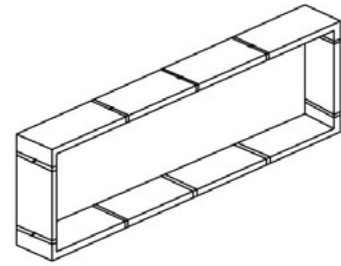

ESTRUTURA - EMBALAGEM
3/3

Passo 1. Remova a fechadura da porta frontal (N), as fechaduras dos painéis laterais e a fechadura do painel traseiro (O); os componentes encontram-se na embalagem 1/3. Em seguida, retire a porta frontal em vidro (A), o painel traseiro (B) e os painéis laterais (C) da embalagem 2/3. Nesta fase começamos por montar as fechaduras nos componentes acima indicados.

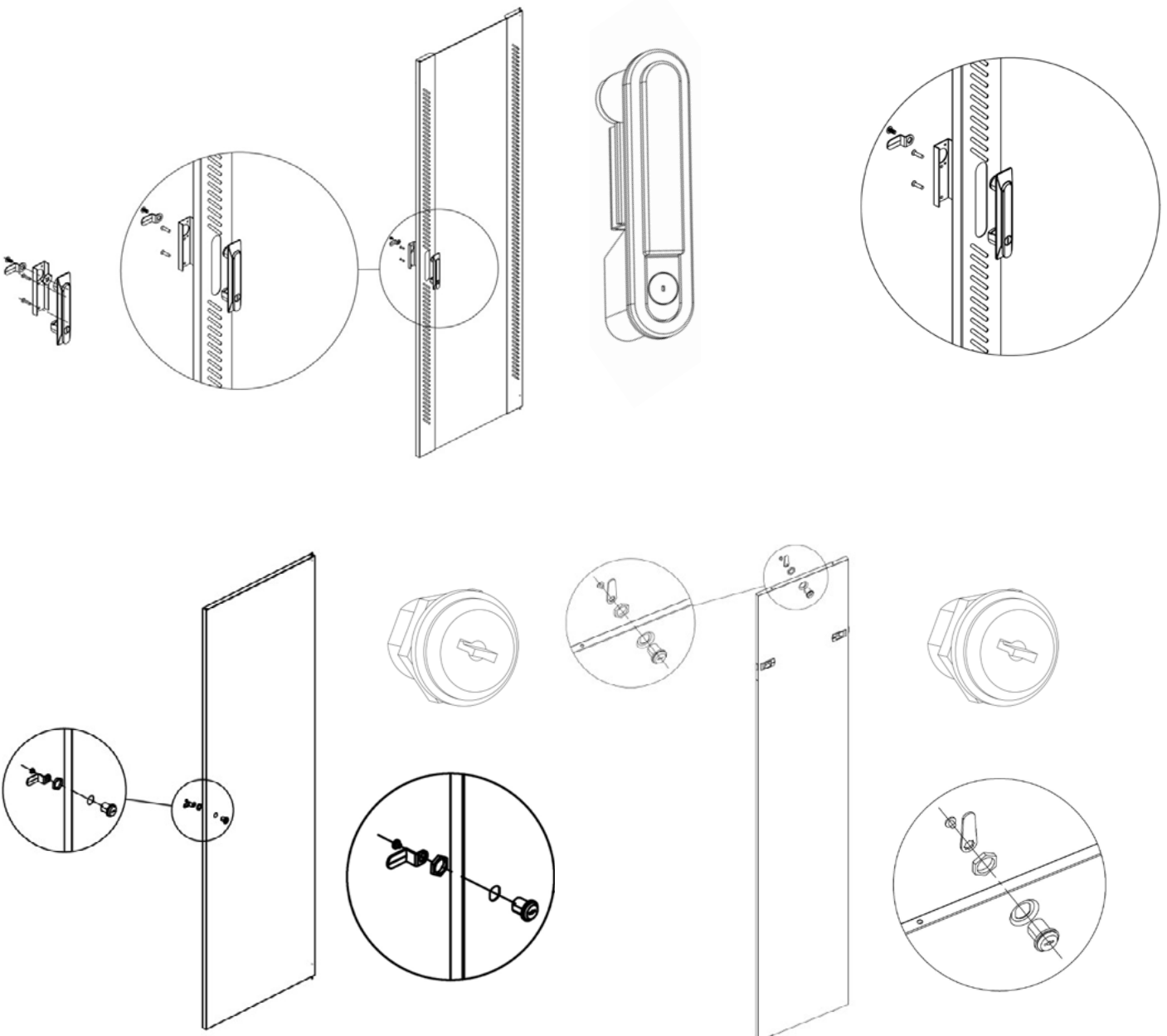

Passo 2. Retire as partes da estrutura (D) da embalagem 3/3. Em seguida, disponha as estruturas paralelas entre si, com os orifícios quadrados voltados para o interior. Pode identificar a parte inferior da estrutura pelas peças de aterramento.

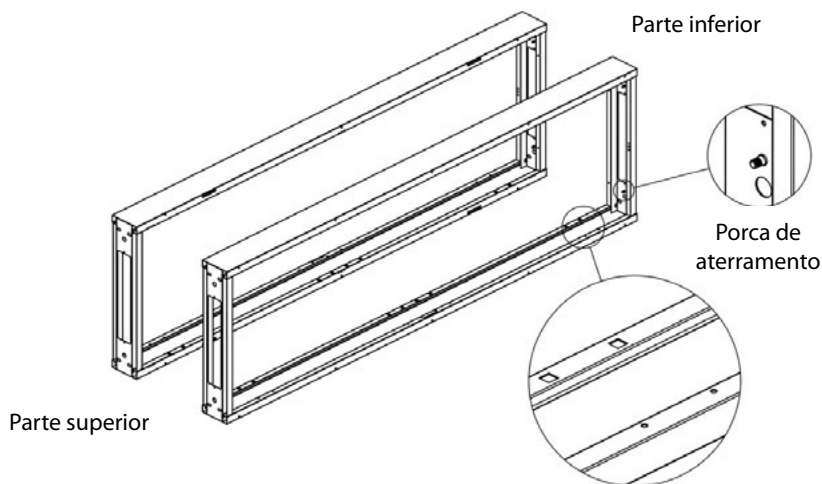

Passo 3. Encaixe a tampa superior (E) nas partes superiores da estrutura (D) e ligue-as com um parafuso Allen M8 (Q).

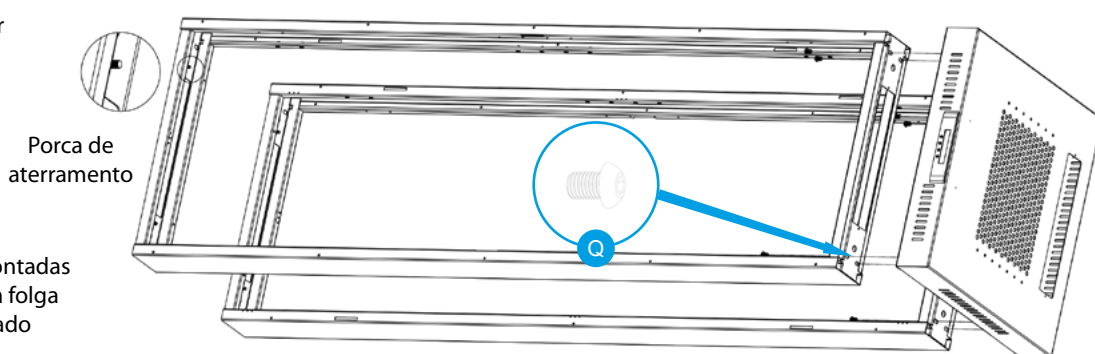

Nota: As estruturas devem ser montadas na tampa de forma que não exista folga entre a estrutura e a tampa pelo lado interno.

Passo 4. Coloque a tampa inferior (F) na parte inferior da estrutura (D) e utilize o parafuso Allen M8 (Q) para as ligar.

Nota: As estruturas devem ser montadas na tampa de forma que não exista folga entre a estrutura e a tampa pelo lado interno.

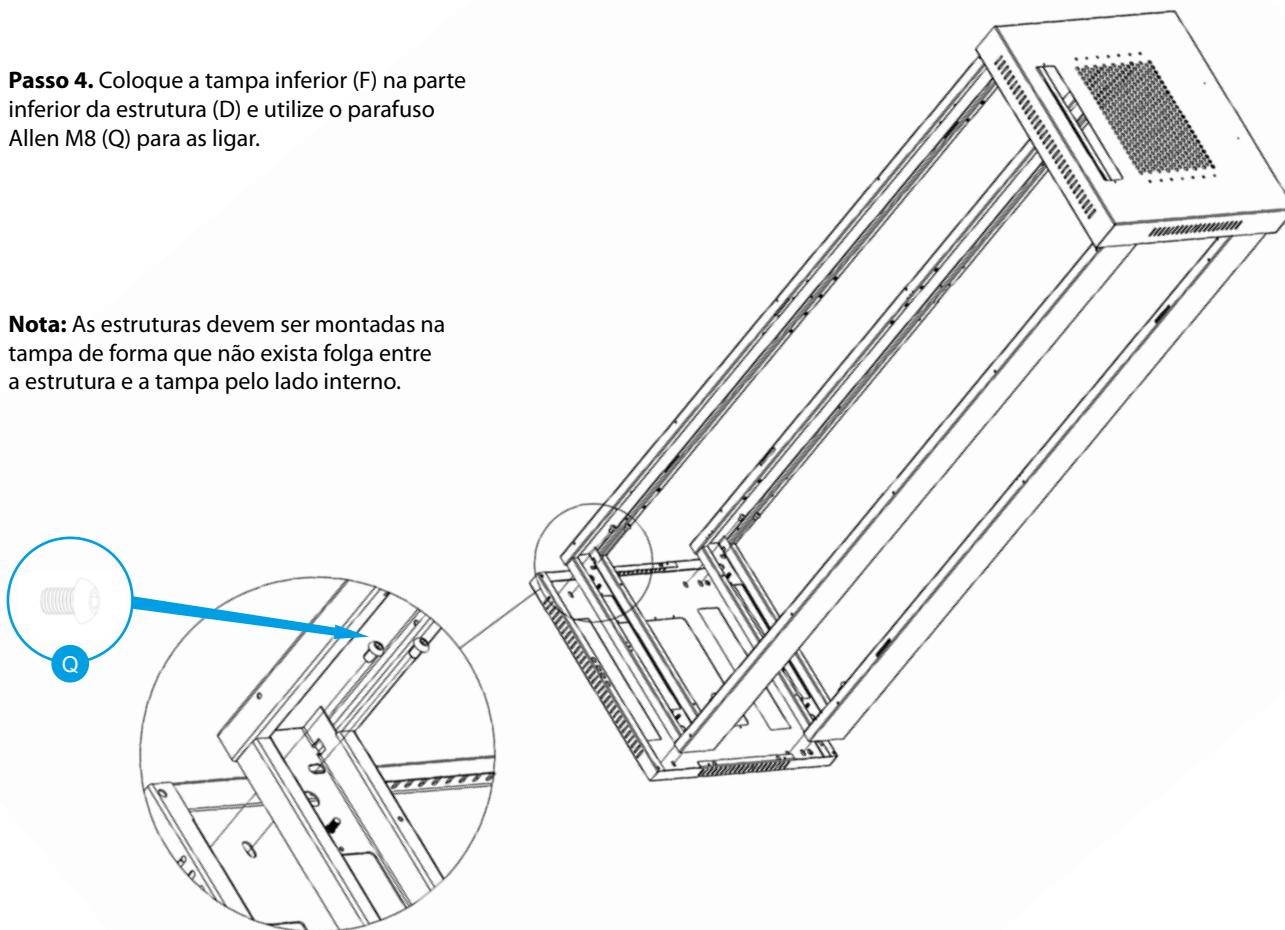

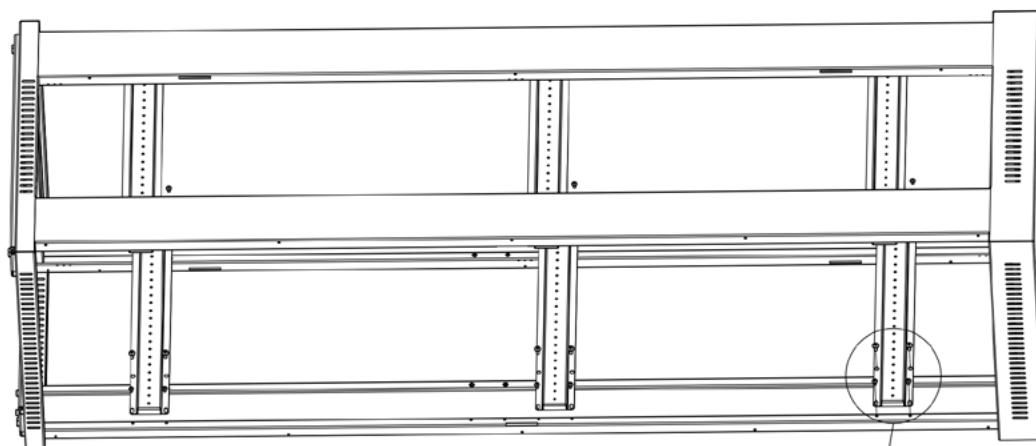

Passo 5. Coloque a travessa (G) na estrutura (D), evitando o orifício destinado à fechadura. Utilize um parafuso M5*10 (R2) e um parafuso autorroscante M5 (R) para fixar a travessa.

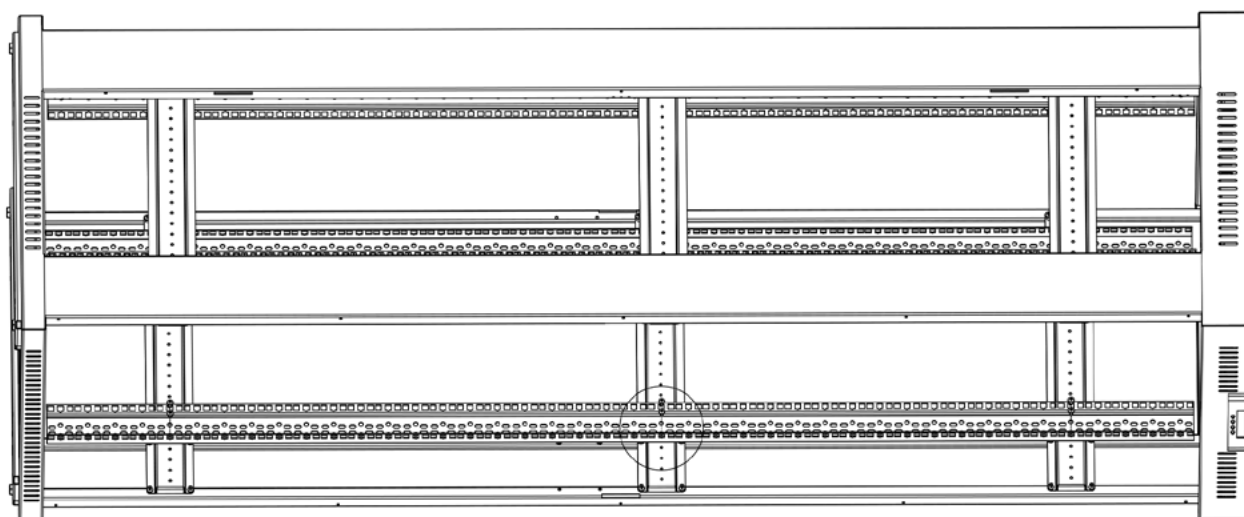
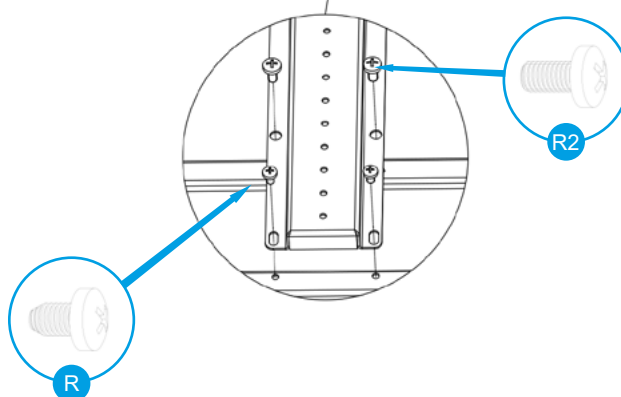

Passo 6. Prepare um parafuso autorroscante M5*10 (R) para fixar os trilhos de montagem verticais (I) às travessas horizontais (G).

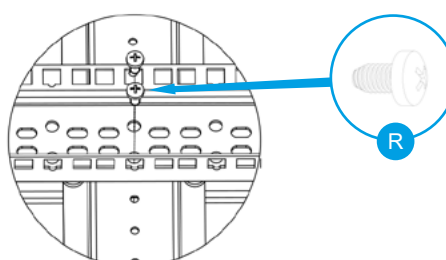

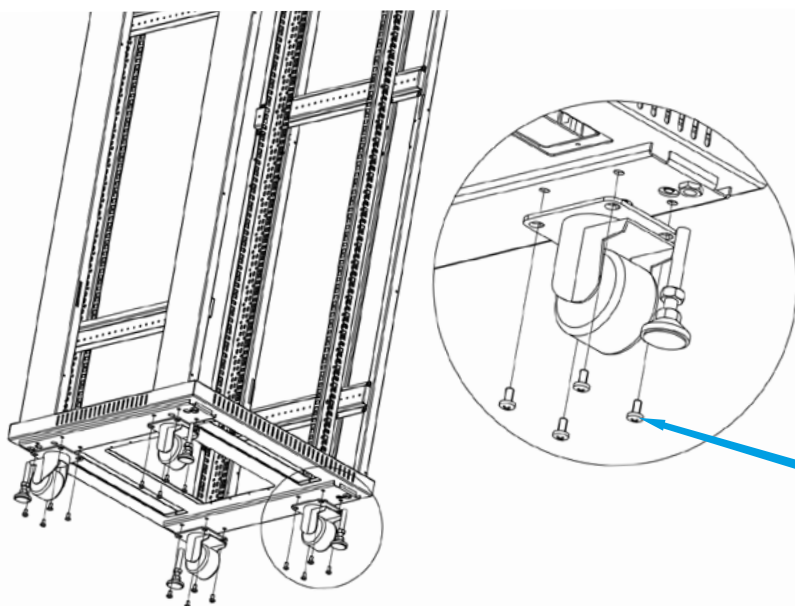

Passo 7. Prepare parafusos com anilha (V2) para fixar os quatro rodízios (L) à tampa inferior (F). Em alternativa, em vez dos rodízios, pode fixar à tampa os pés (K) incluídos no conjunto.

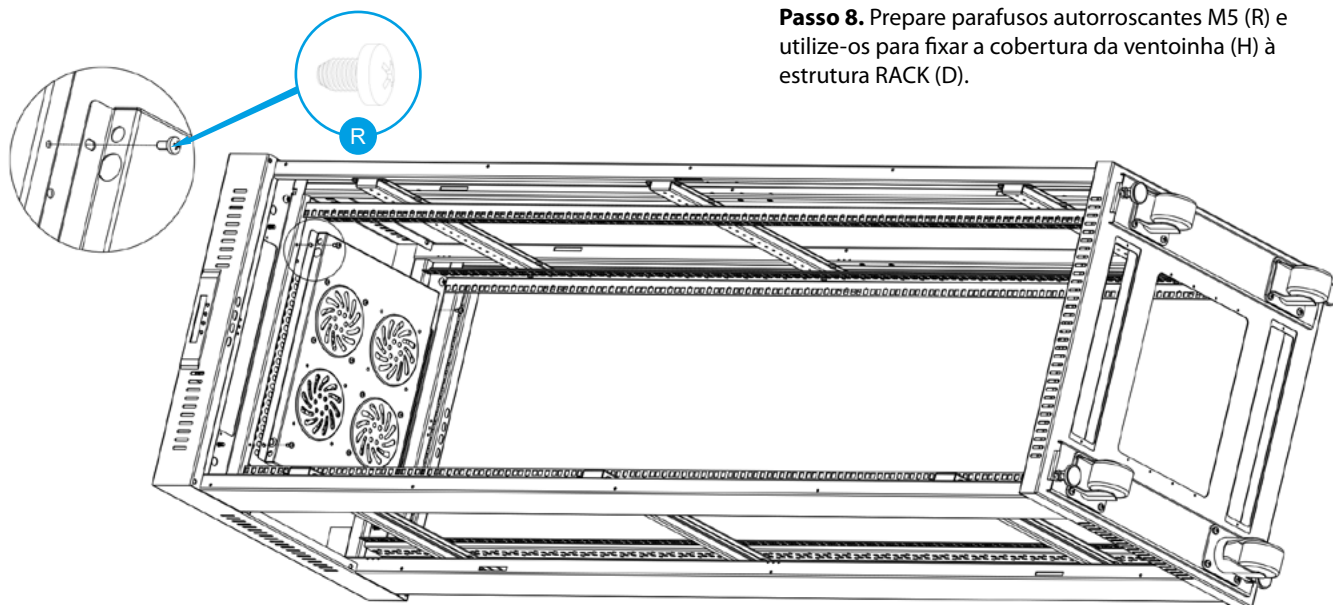

Passo 8. Prepare parafusos autorroscantes M5 (R) e utilize-os para fixar a cobertura da ventoinha (H) à estrutura RACK (D).

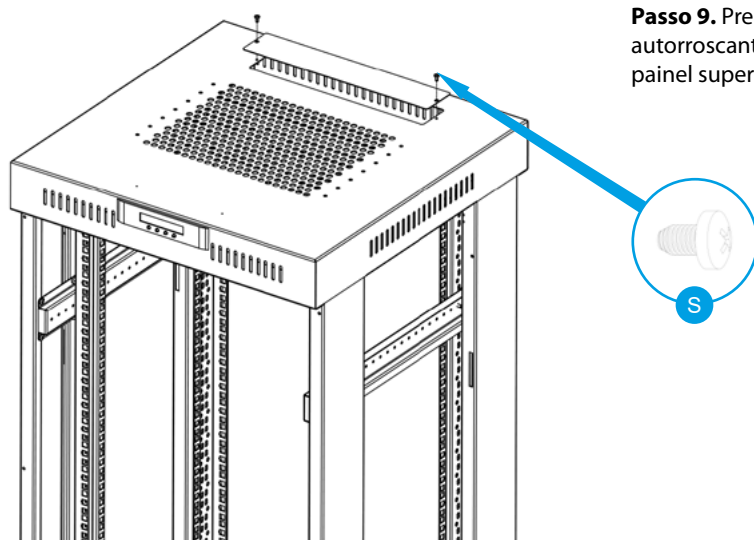

Passo 9. Prepare e utilize um parafuso autorroscante M4 (S) para fixar a tampa do painel superior (J).

Passo 10. Prepare e utilize parafusos autorroscantes M4 (S) para fixar os batentes da porta (M), 12U~27U (8pcs), 32U~47U (12pcs)



Passo 11. Prepare e coloque os espaçadores da porta (W) para a porta frontal e o painel traseiro (itens A e B) nos locais adequados. Monte os painéis laterais (C) apenas no final.

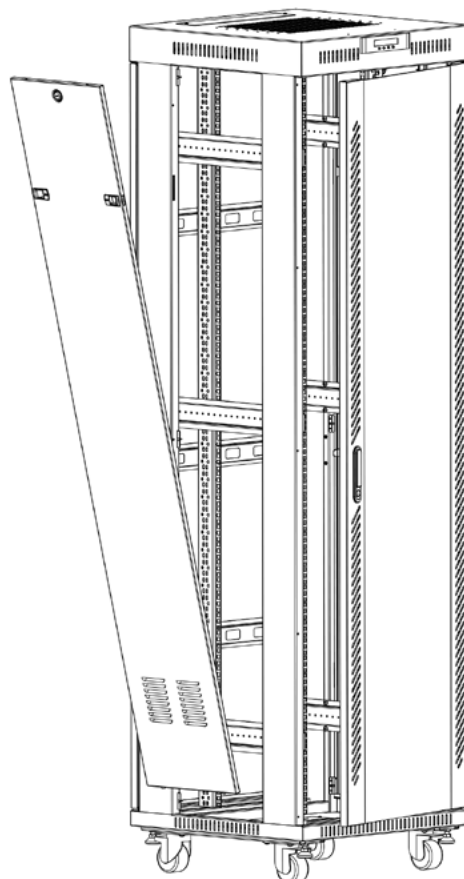
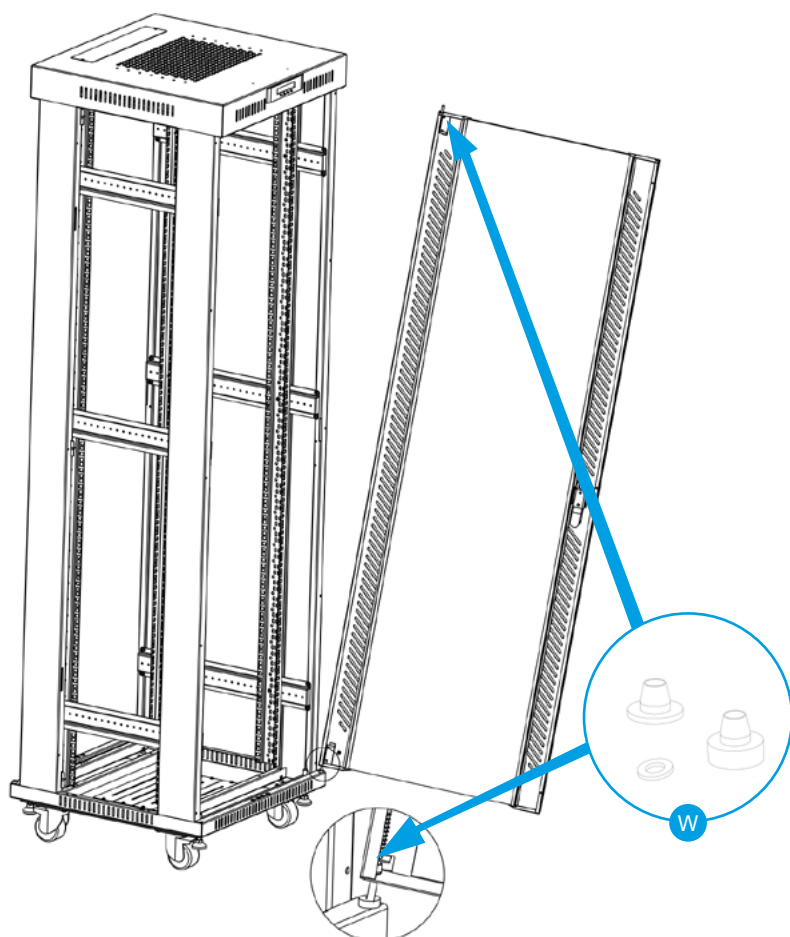
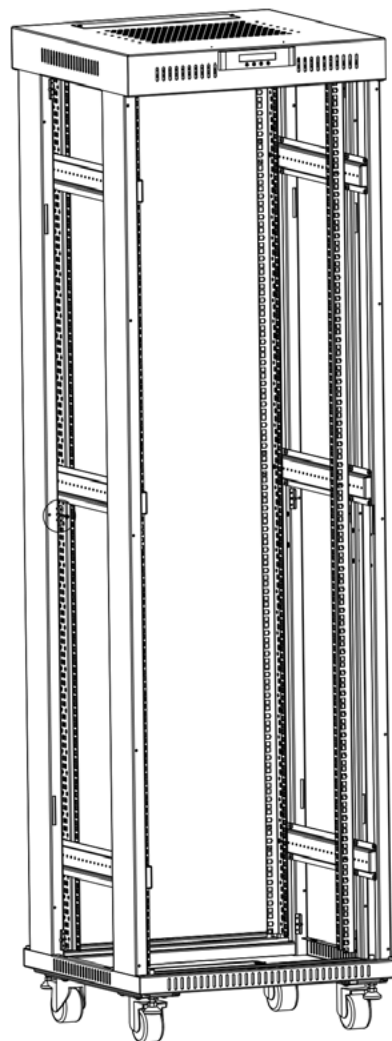







1. Montage





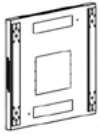
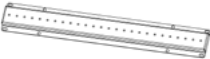
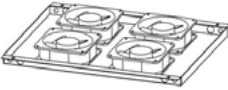

Befolgen Sie die Anweisungen in diesem Handbuch unbedingt genau.







1.1 Vorbereitungen

Bereiten Sie auf der Fläche, auf der die Montage erfolgt, ausreichend freien Platz vor. Nehmen Sie alle Elemente vorsichtig aus der Transportverpackung. Die weiteren Montageschritte basieren auf der bereitgestellten Abbildung.

1.1.1. Komponententabelle

Schrankelemente		
Artikelnr.	Zeichnung	Liefermenge
A		1
B		1
C		2
D		2
E		1
F		1
G		15U~27U 4 32U~47U 6
H		1
I		4
J		3 4

K		4
L		4
M		15U~27U 8 32U~47U 12
N		1
O		3
W		4

Schrauben			
Artikelnr.	Zeichnung	Liefermenge	
Q		17	
R		15U~27U	38
		32U~47U	54
S		15U~27U	24
		32U~47U	28
R2		15U~27U	18
		32U~47U	26
V		20	
V2		17	

2. Montageschritte

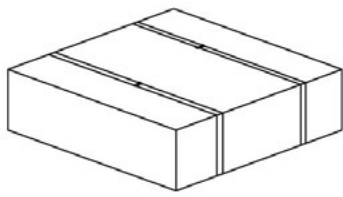

OBEN & UNTEN - PAKET 1/3

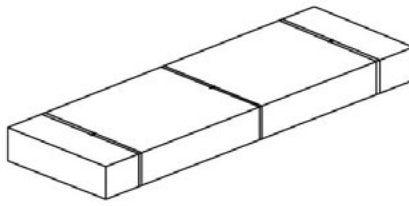

VORDER-, RÜCK- UND
SEITENTÜREN - PAKET 2/3

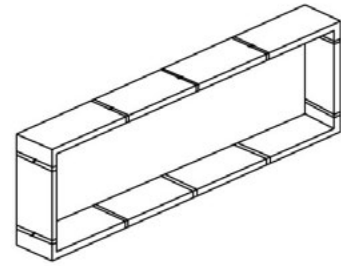

RAHMEN - PAKET 3/3

Schritt 1. Entfernen Sie das Schloss der Vordertür (N), die Schlösser der Seitenwände sowie das Schloss der Rückwand (O); die Komponenten befinden sich in Paket 1/3. Entfernen Sie anschließend die vordere Glastür (A), die Rückwand (B) und die Seitenwände (C) aus Paket 2/3. In diesem Schritt beginnen wir mit der Montage der Schlösser an den oben genannten Komponenten.

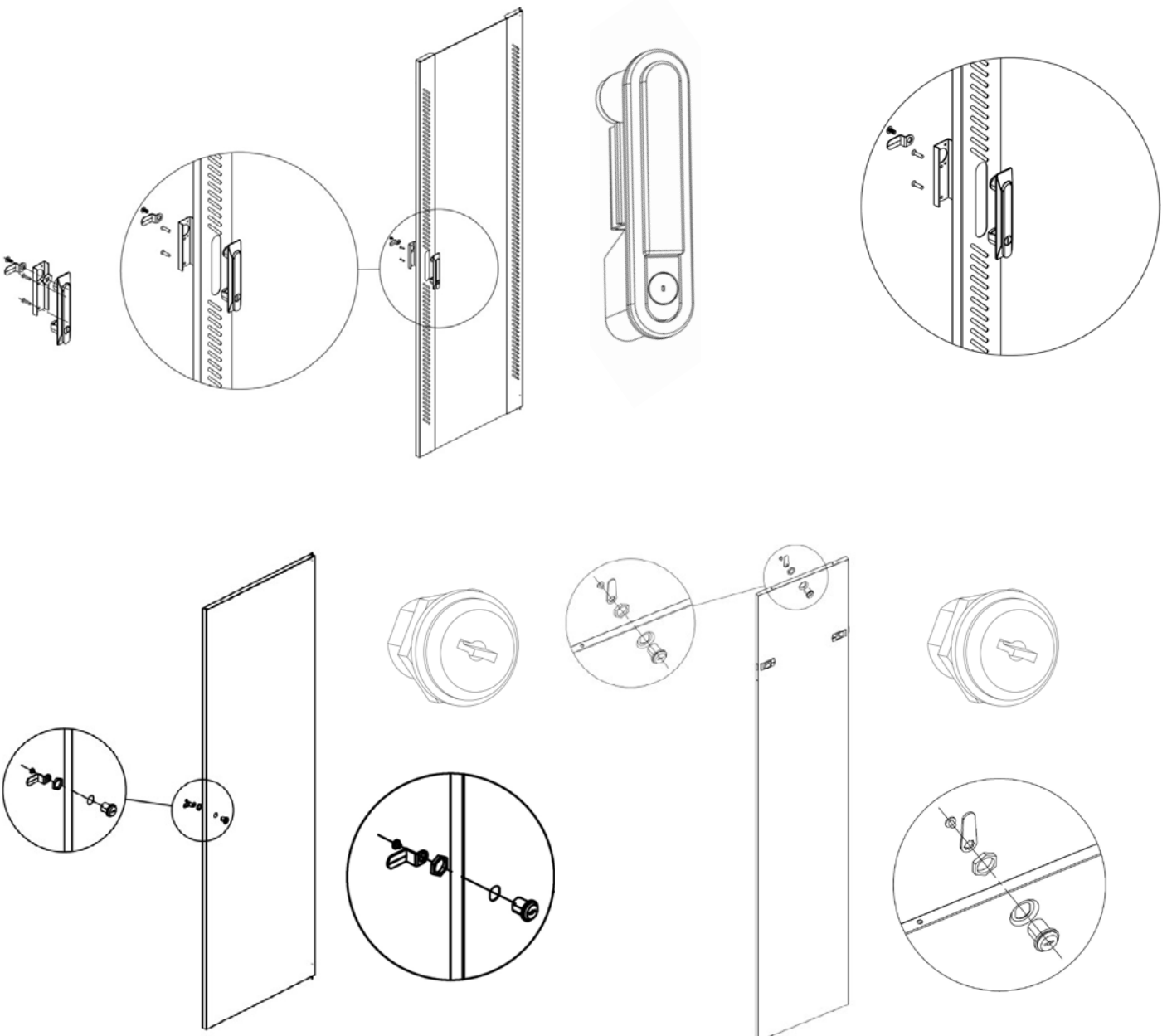

Schritt 2. Packen Sie die Rahmenteile (D) aus Paket 3/3 aus. Ordnen Sie die Rahmen anschließend parallel zueinander an, wobei die quadratischen Öffnungen nach innen zeigen. Den unteren Teil des Rahmens erkennen Sie an den Erdungselementen.

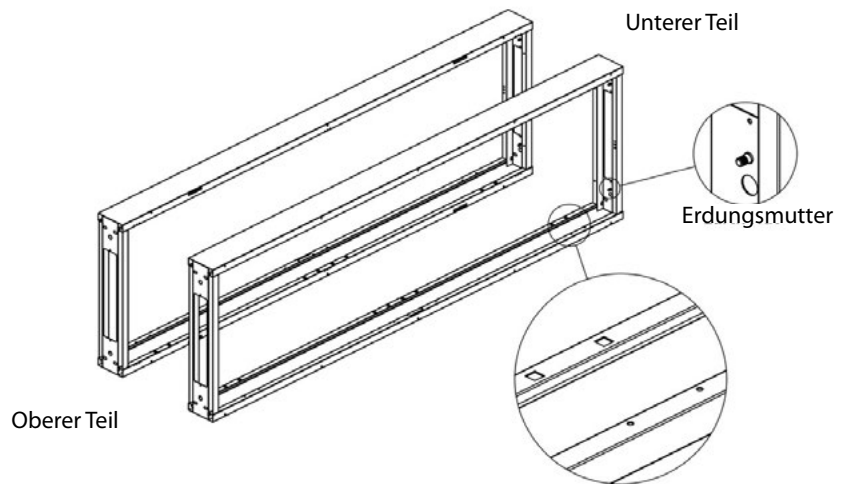

Schritt 3. Setzen Sie die obere Abdeckung (E) auf die oberen Teile des Rahmens (D) und verbinden Sie sie anschließend mit einer M8-Innensechskantschraube (Q).

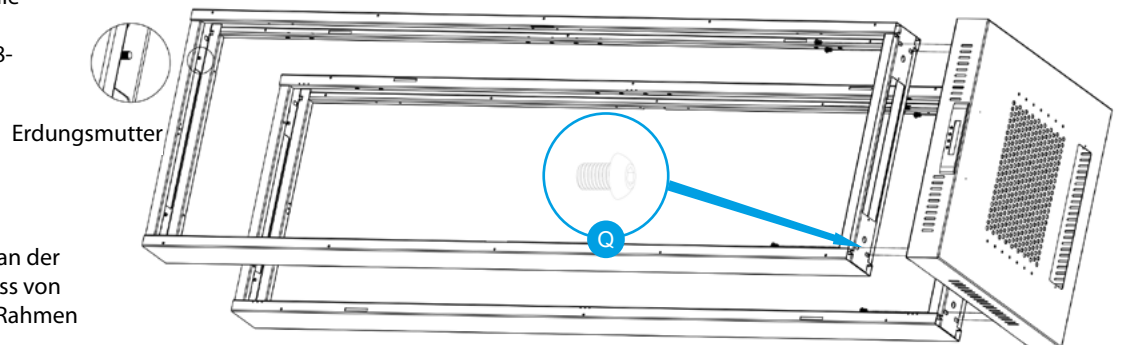

Hinweis: Die Rahmen sollten so an der Abdeckung montiert werden, dass von innen kein freier Spalt zwischen Rahmen und Abdeckung bleibt.

Schritt 4. Platzieren Sie die untere Abdeckung (F) am unteren Teil des Rahmens (D) und verwenden Sie die M8-Innensechskantschraube (Q), um sie zu verbinden.

Hinweis: Die Rahmen sollten so an der Abdeckung montiert werden, dass von innen kein freier Spalt zwischen Rahmen und Abdeckung bleibt.

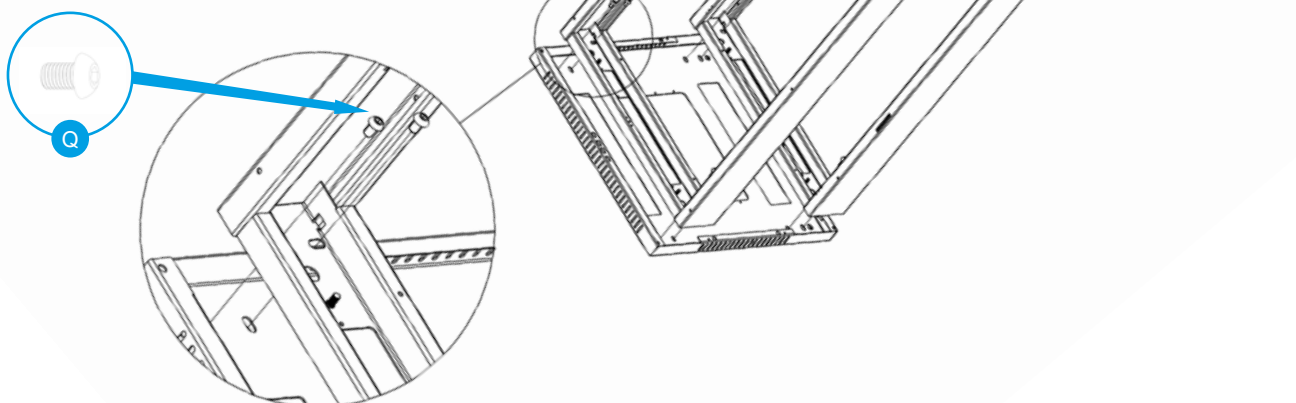

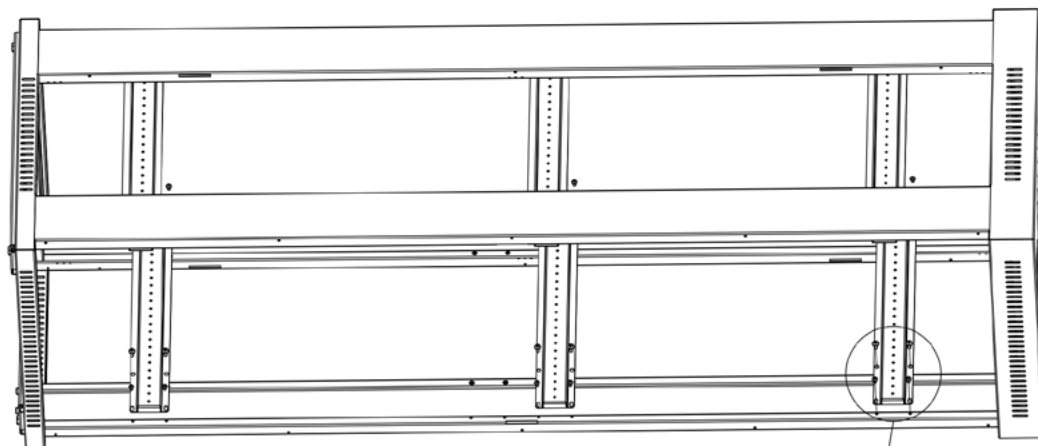

Schritt 5. Platzieren Sie die Querstrebe (G) auf dem Rahmen (D), wobei Sie die für das Schloss vorgesehene Öffnung aussparen. Verwenden Sie eine M5*10-Schraube (R2) und eine M5-Blechschaube (R), um die Querstrebe zu befestigen.

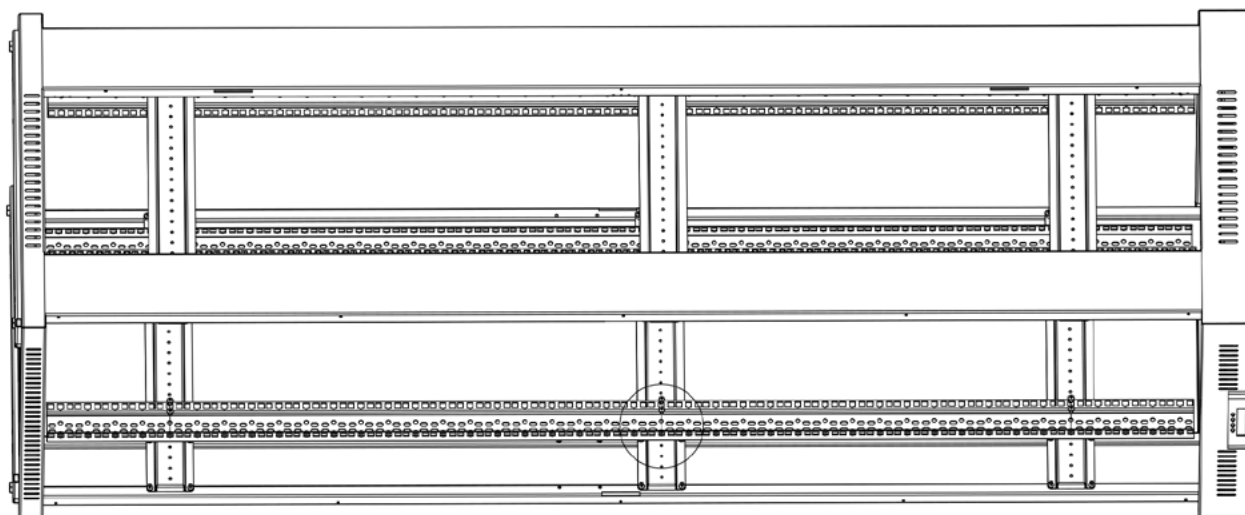
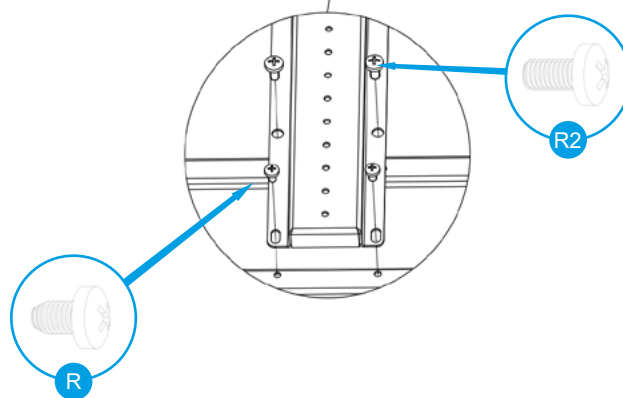

Schritt 6. Bereiten Sie eine M5*10-Blechschaube (R) vor, um die vertikalen Montageschienen (I) an den horizontalen Quertraversen (G) zu befestigen.

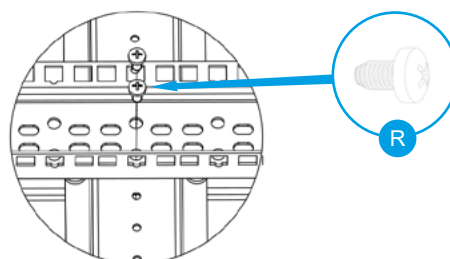

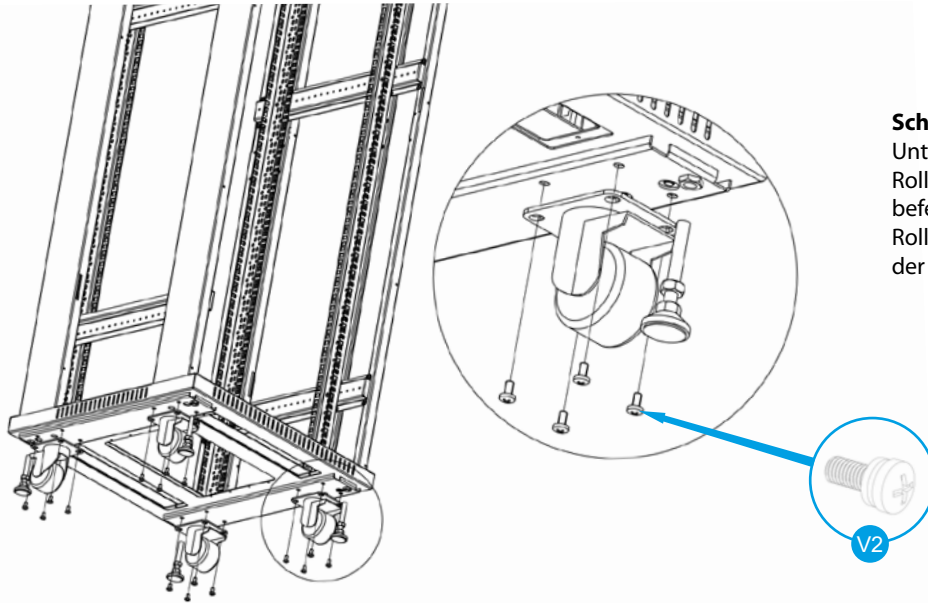

Schritt 7. Bereiten Sie Schrauben mit Unterlegscheibe (V2) vor, um die vier Rollen (L) an der unteren Abdeckung (F) zu befestigen. Alternativ können Sie statt der Rollen die im Set enthaltenen FüÙe (K) an der Abdeckung befestigen.

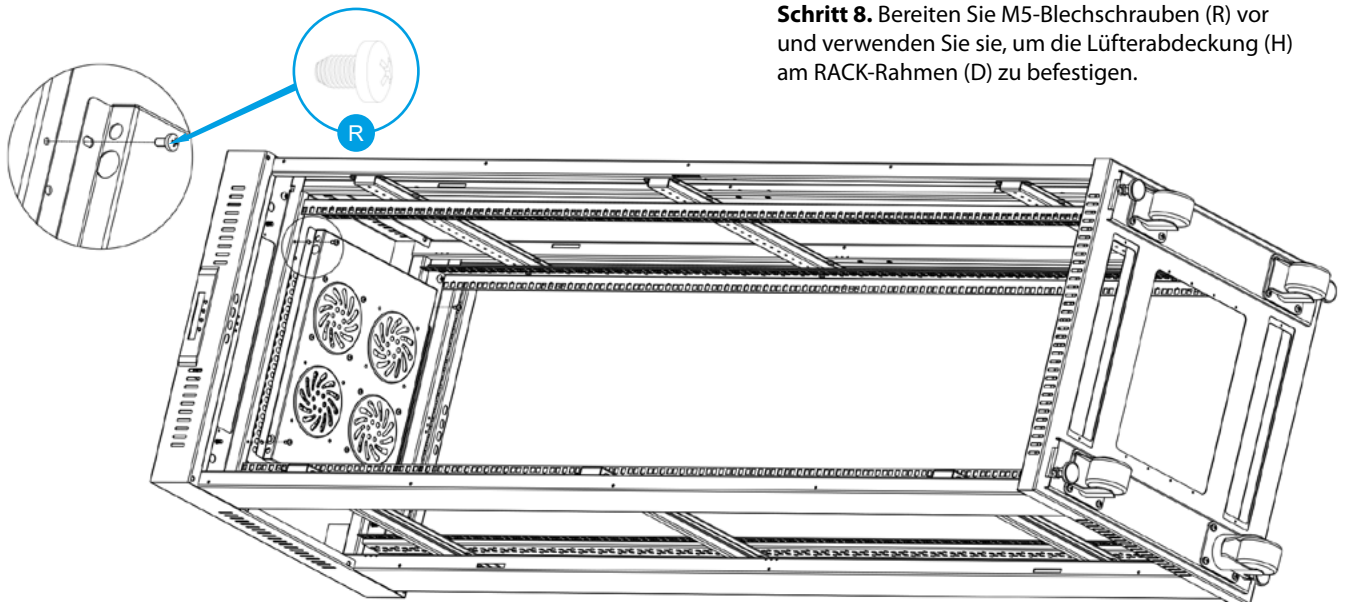

Schritt 8. Bereiten Sie M5-Blechsrauben (R) vor und verwenden Sie sie, um die Lüfterabdeckung (H) am RACK-Rahmen (D) zu befestigen.

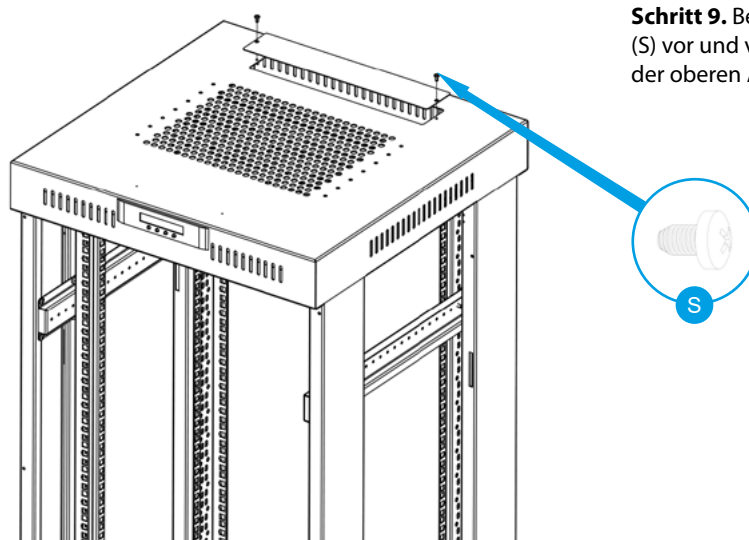

Schritt 9. Bereiten Sie eine M4-Blechschaube (S) vor und verwenden Sie sie zur Befestigung der oberen Abdeckungskappe (J).

Schritt 10. Bereiten Sie M4-Blechschraben (S) vor und verwenden Sie sie zur Befestigung der Türanschlüge (M), 12U~27U (8), 32U~47U (12).

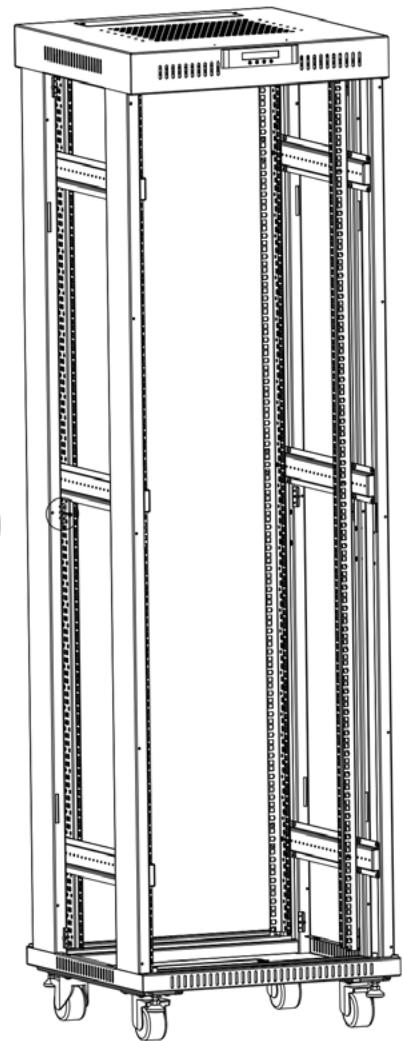

Schritt 11. Bereiten Sie die Türabstandshalter (W) für die Vordertür und die Rückwand (Items A und B) vor und setzen Sie sie an den entsprechenden Stellen ein. Montieren Sie die Seitenwände (C) ganz zum Schluss.

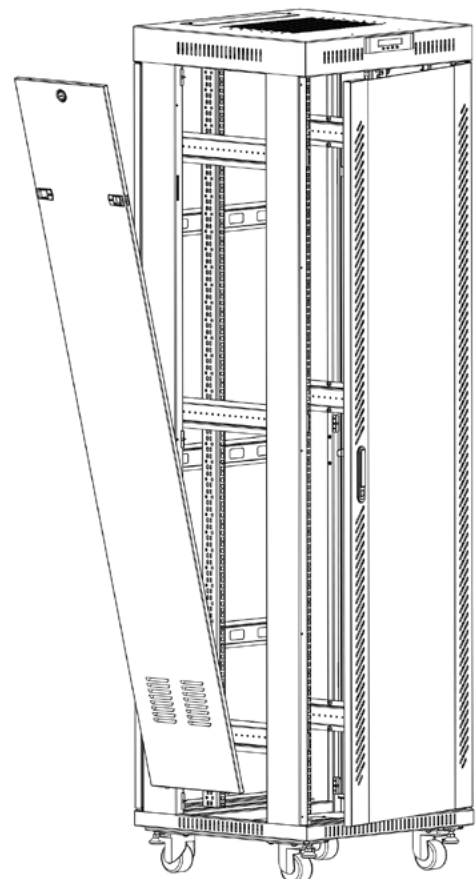
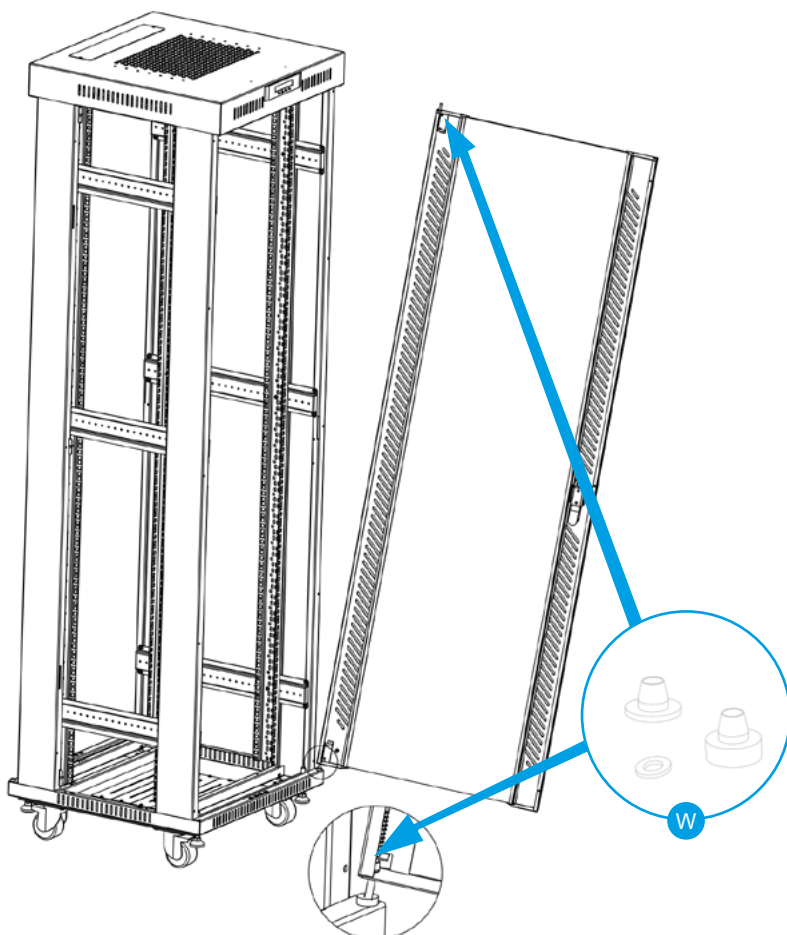







1. Montering





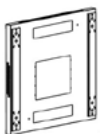
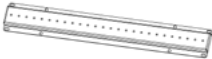
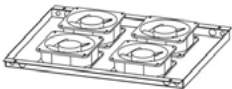

Var noga med att strikt följa instruktionerna i denna manual.







1.1 Förberedelser

Förbered tillräckligt med fritt utrymme på ytan där monteringen ska utföras. Ta försiktigt ut alla delar ur transportlådan. De fortsatta monteringsanvisningarna baseras på det medföljande diagrammet

1.1.1. Komponenttabell

Skåpdelar		
Artikelnr.	Ritning	Medföljande antal
A		1
B		1
C		2
D		2
E		1
F		1
G		15U~27U 4 32U~47U 6
H		1
I		4
J		3 4

K		4
L		4
M		15U~27U 8 32U~47U 12
N		1
O		3
W		4

Skrudar			
Artikelnr.	Ritning	Medföljande antal	
Q		17	
R		15U~27U	38
		32U~47U	54
S		15U~27U	24
		32U~47U	28
R2		15U~27U	18
		32U~47U	26
V		20	
V2		17	

2. Monteringssteg

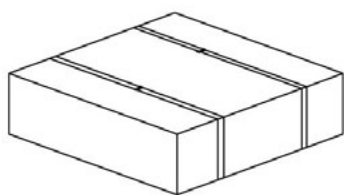

TOPP OCH BOTTEN - PAKET
1/3

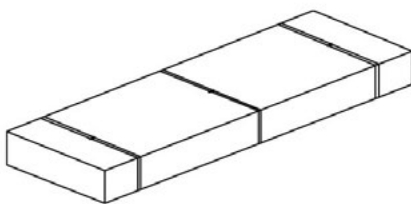

FRÄMRE, BAKRE OCH
SIDODÖRRAR - PAKET 2/3

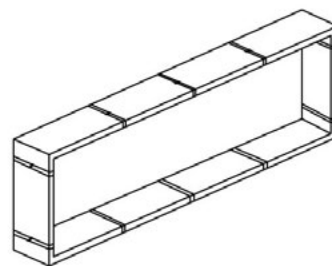

RAMPAKET 3/3

Steg 1. Ta bort låset till framdörren (N), låsen till sidopanelerna och låset till bakpanelen (O); komponenterna finns i paket 1/3. Ta sedan ut framdörren i glas (A), bakpanelen (B) och sidopanelerna (C) från paket 2/3. I detta steg börjar vi med att montera låsen på ovanstående komponenter.

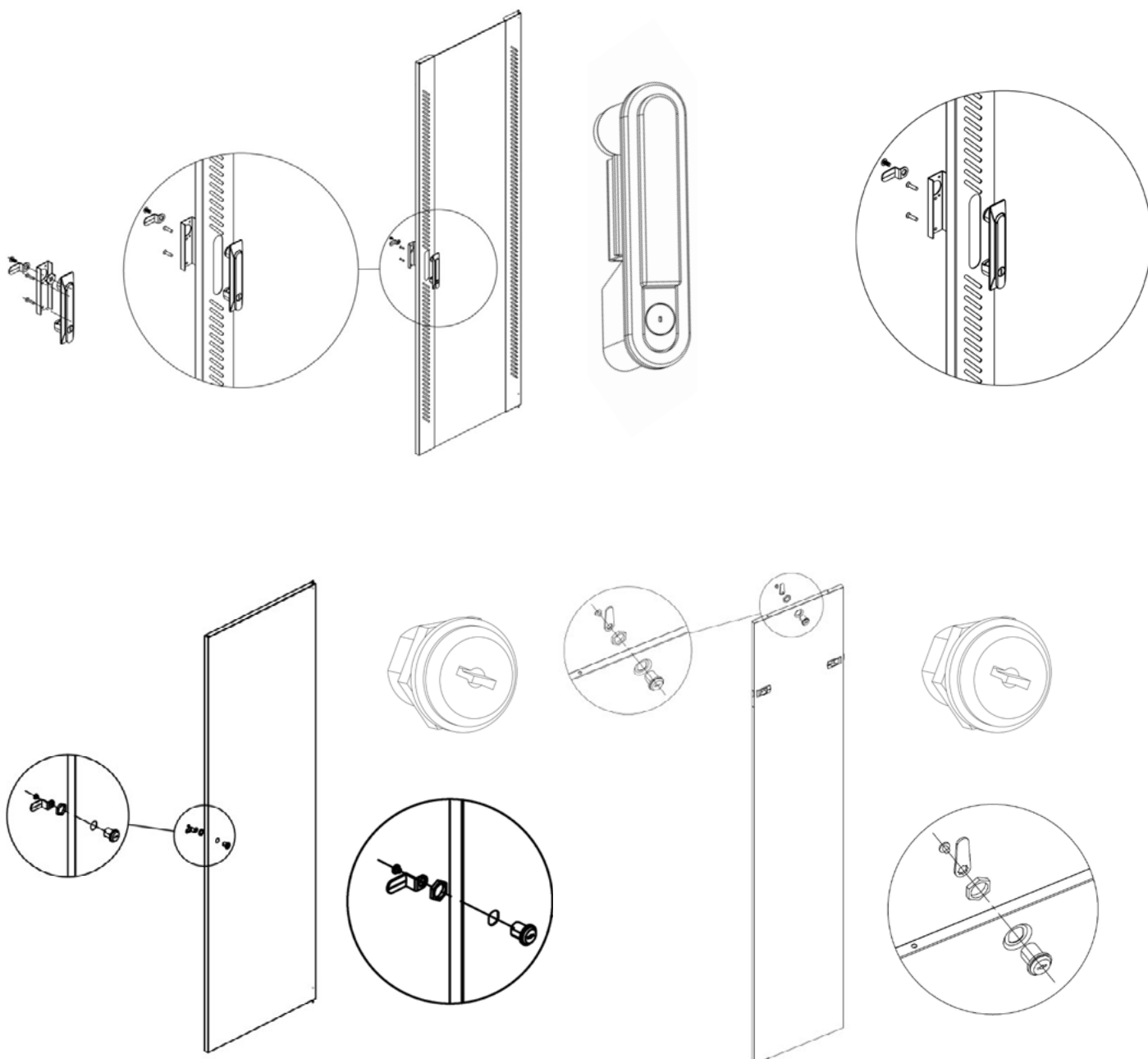

Steg 2. Packa upp ramdelarna (D) från paket 3/3. Placera sedan ramarna parallellt med varandra, med de fyrkantiga hålen vända inåt. Du kan identifiera den nedre delen av ramen genom jordningsdelarna.

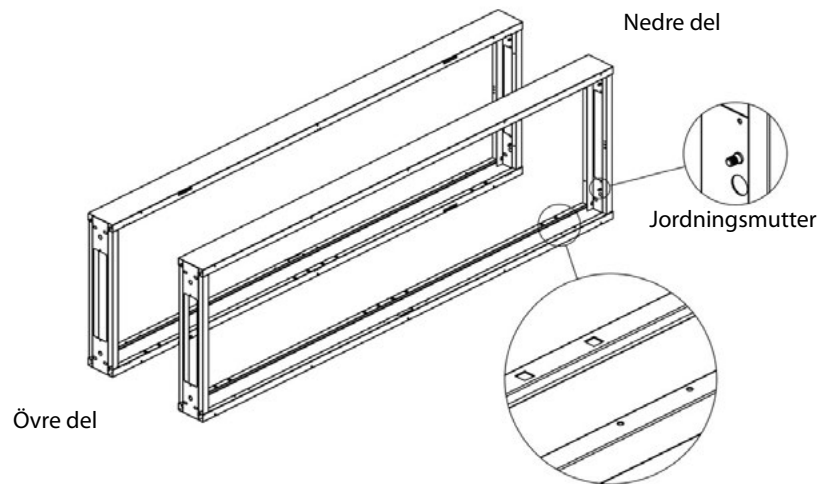

Steg 3. Montera topplocket (E) på de övre delarna av ramen (D) och sammanfoga dem sedan med en M8 insexskruv (Q).

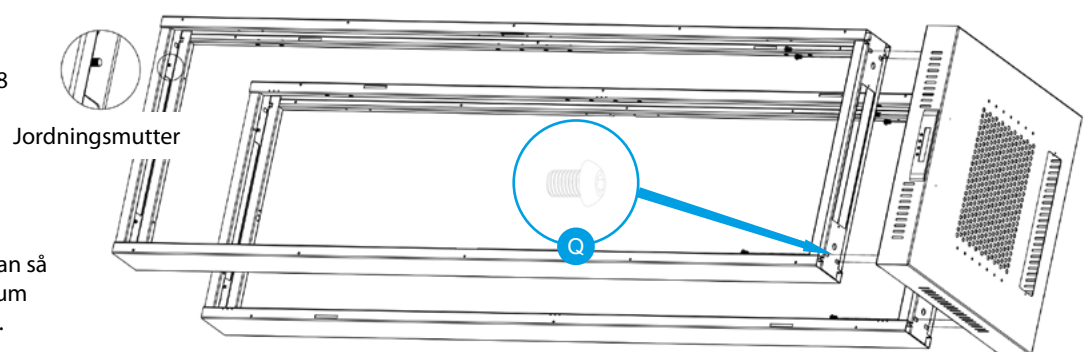

Obs: Ramarna ska monteras på kåpan så att det inte finns något fritt mellanrum mellan ramen och kåpan på insidan.

Steg 4. Placera bottenkåpan (F) på den nedre delen av ramen (D) och använd M8 insexskruven (Q) för att sammanfoga dem.

Obs: Ramarna ska monteras på kåpan så att det inte finns något fritt mellanrum mellan ramen och kåpan på insidan.

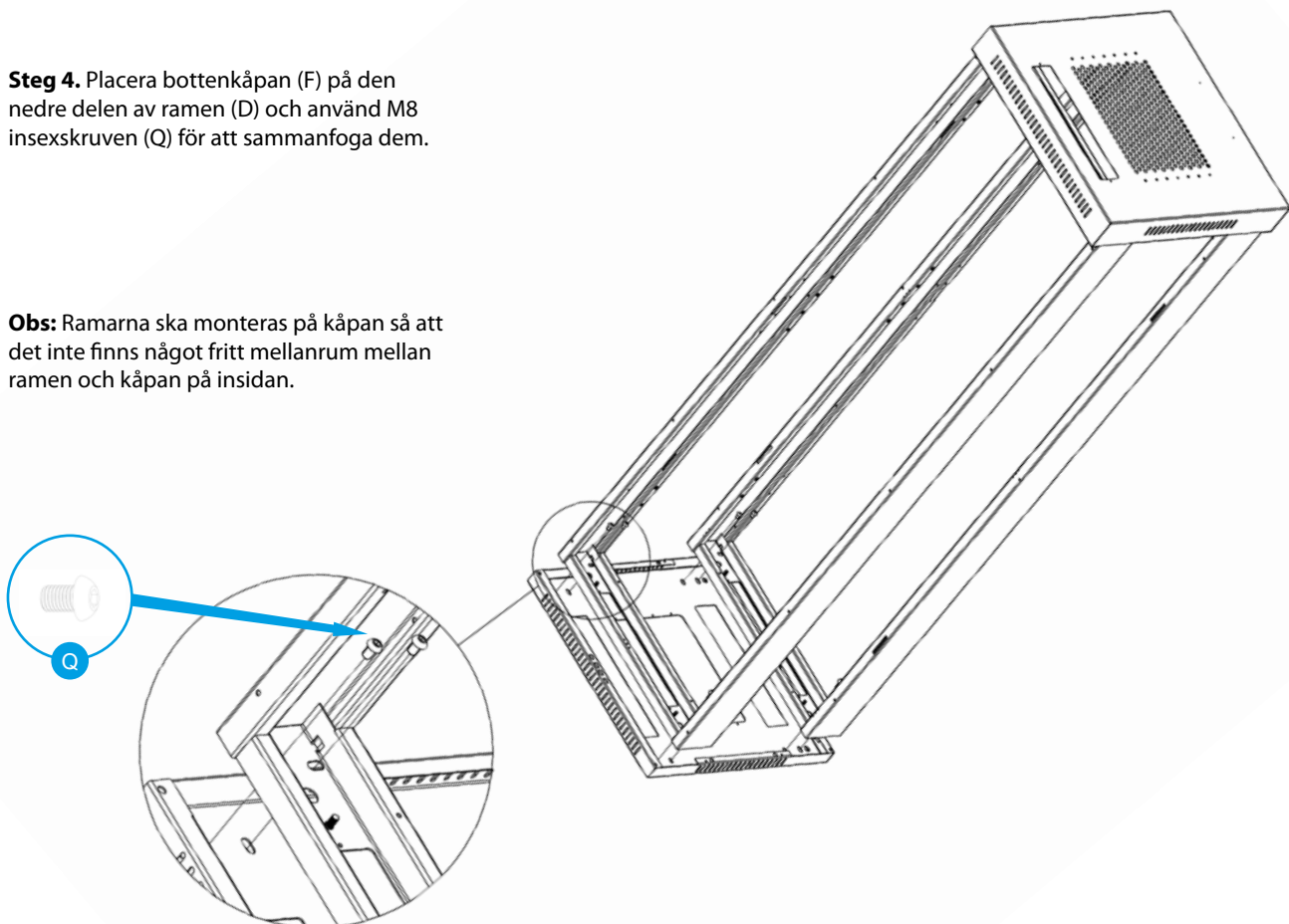

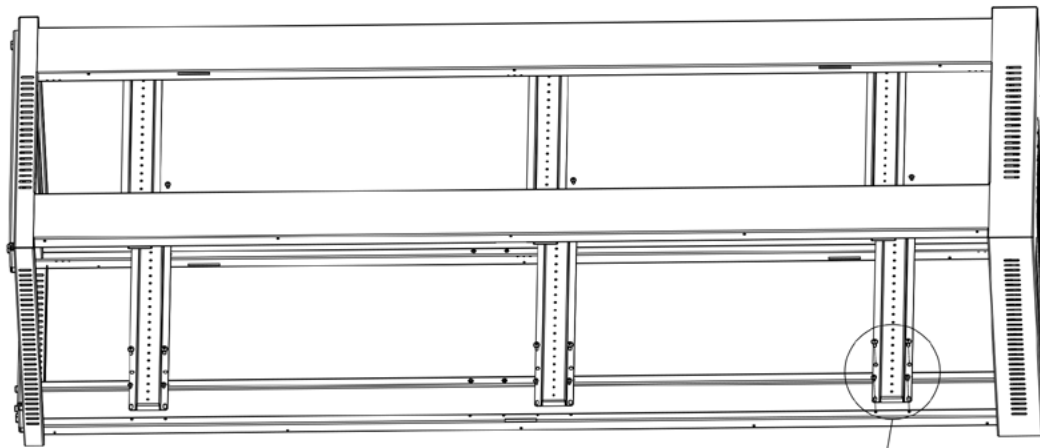

Steg 5. Placera tvärbalken (G) på ramen (D) och undvik hålet som är avsett för låset. Använd en M5*10-skruv (R2) och en M5 självgängande skruv (R) för att fästa tvärbalken.

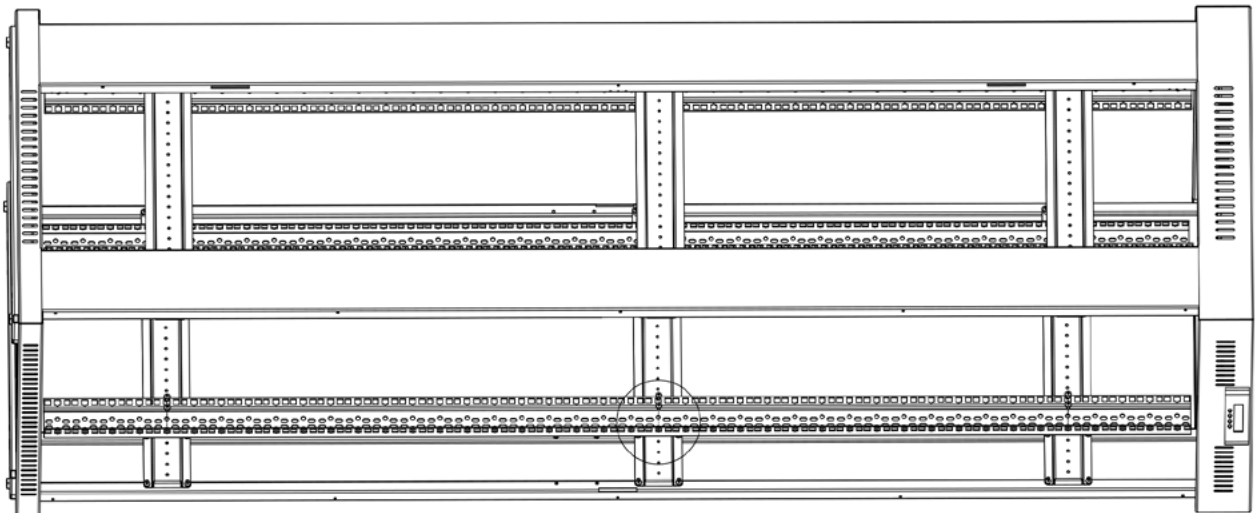
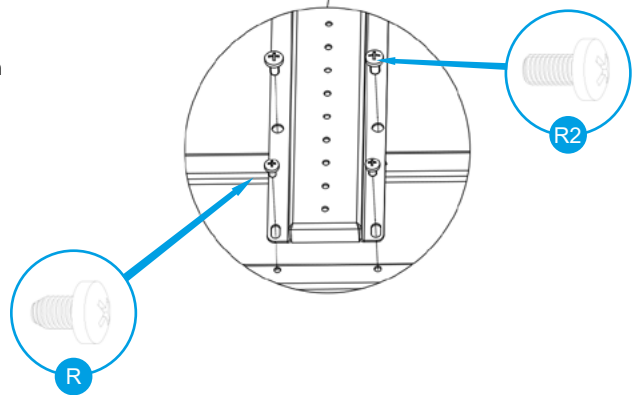

Steg 6. Förbered en M5*10 självgängande skruv (R) för att fästa de vertikala monteringskenorna (I) vid de horisontella tvärbalkarna (G).

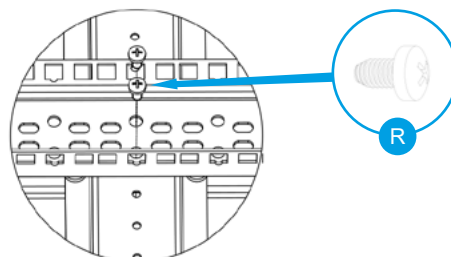

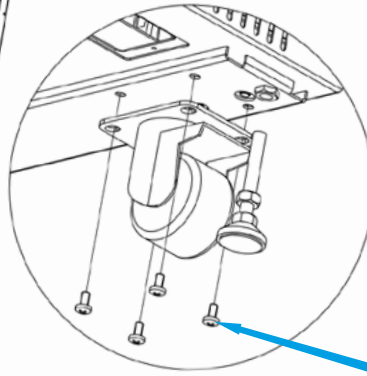
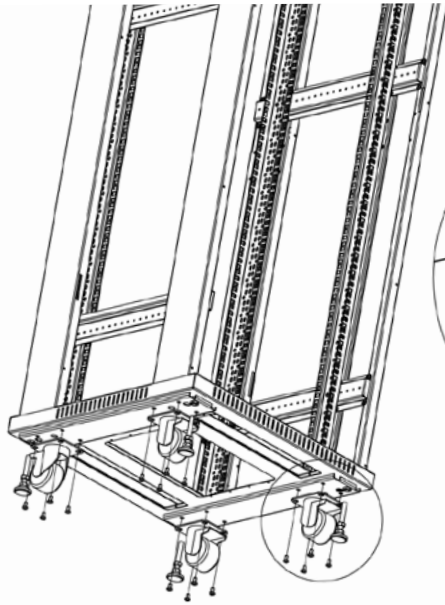

Steg 7. Förbered skruvar med bricka (V2) för att fästa de fyra hjulen (L) på bottenkåpan (F). I stället för hjulen kan du även fästa fötterna (K), som ingår i satsen, på kåpan.

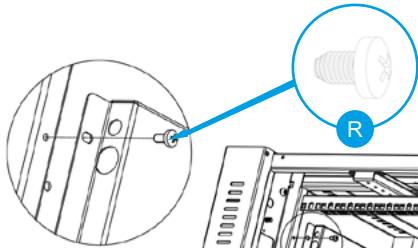
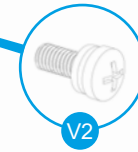

Steg 8. Förbered M5 självgående skruvar (R) och använd dem för att fästa flätkåpan (H) till RACK-ramen (D).

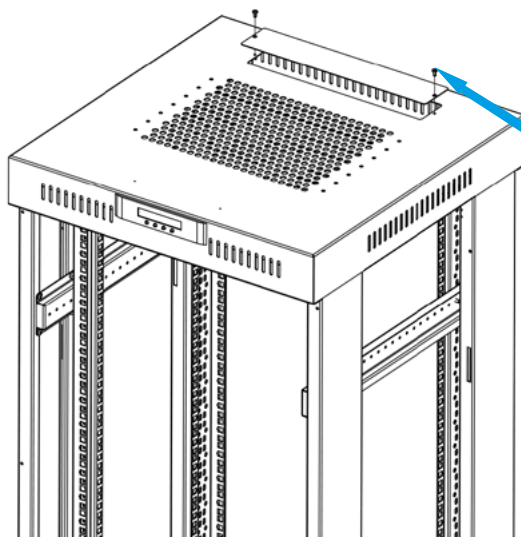
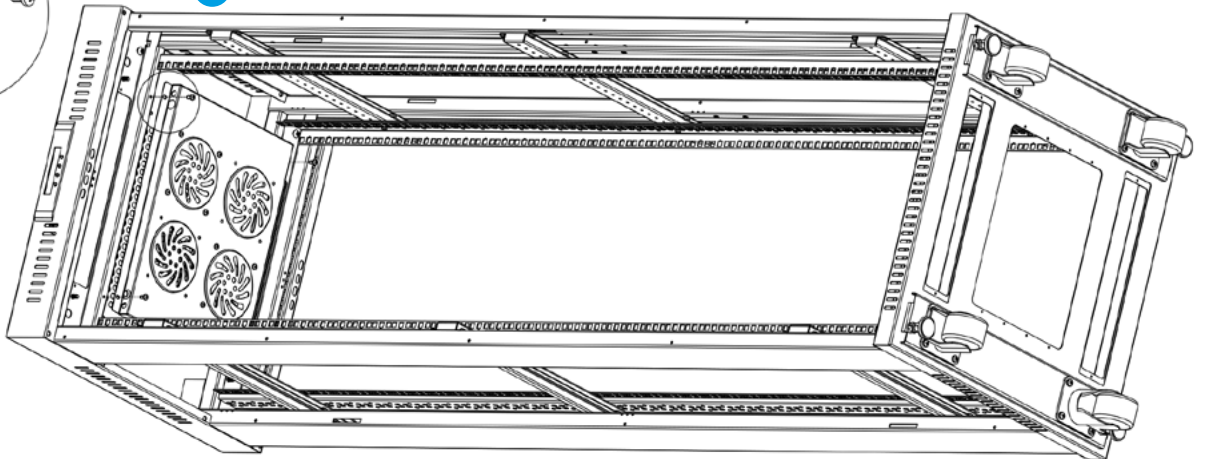

Steg 9. Förbered och använd en M4 självgående skruv (S) för att fästa topplocket till panelen (J).

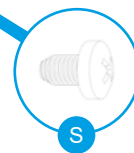

Steg 10. Förbered och använd M4 självgående skruvar (S) för att fästa dörrestoppen (M), 12U~27U (8), 32U~47U (12).

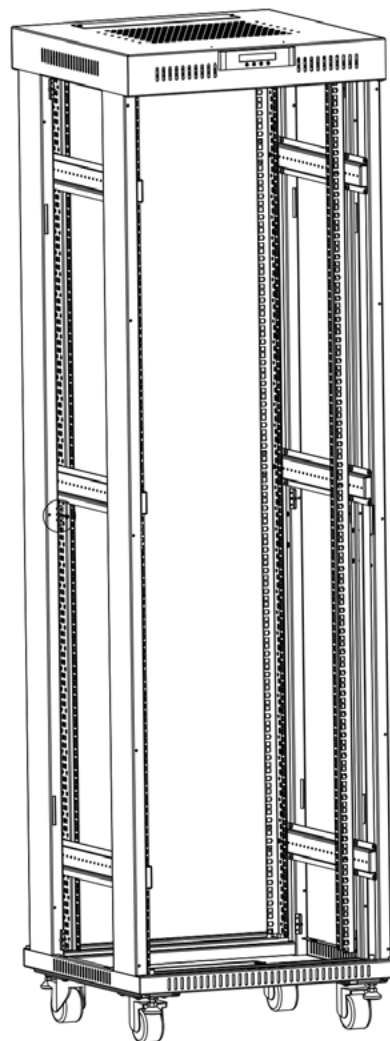
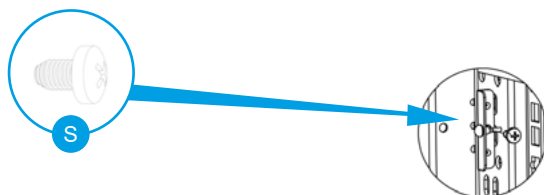

Steg 11. Förbered och placera dörddistansdelarna (W) för främrdörren och bakpanelen (items A och B) på rätt platser. Montera sidopanelerna (C) allra sist.

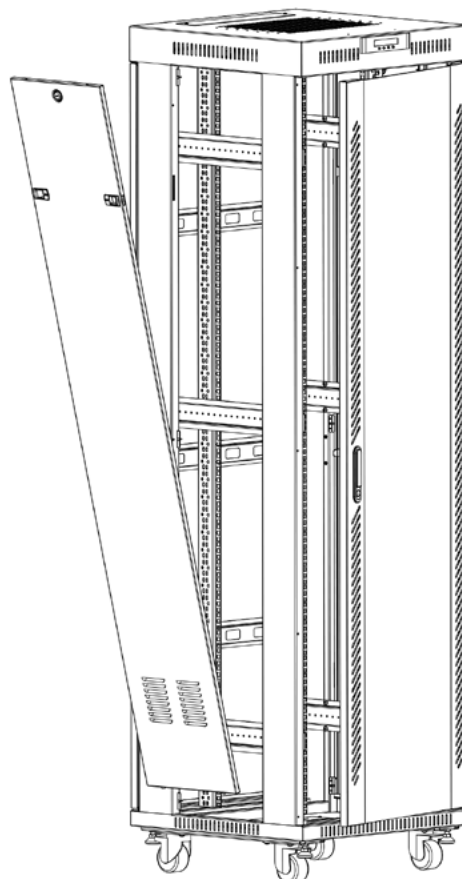
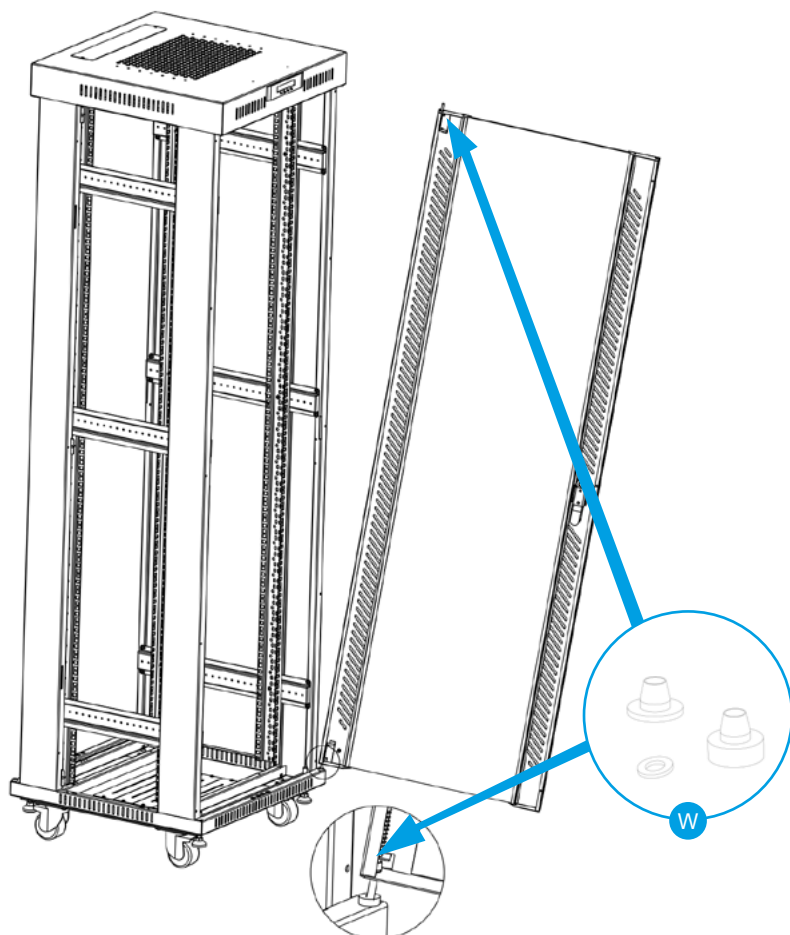









1. Assemblaggio





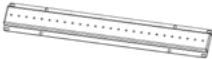
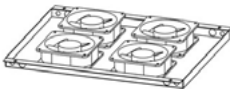

Assicurarsi di seguire rigorosamente le istruzioni di questo manuale.







1.1 Preparazione

Preparare una quantità adeguata di spazio libero sulla superficie su cui avverrà il montaggio. Rimuovere con attenzione tutti gli elementi dalla scatola di trasporto. Le ulteriori istruzioni di montaggio si baseranno sul diagramma fornito

1.1.1. Tabella dei componenti

Elementi dell'armadio		
N. articolo	Disegno	Quantità fornita
A		1
B		1
C		2
D		2
E		1
F		1
G		15U~27U 4 32U~47U 6
H		1
I		4
J		3 4

K		4
L		4
M		15U~27U 8 32U~47U 12
N		1
O		3
W		4

Viti			
N. articolo	Disegno	Quantità fornita	
Q		17	
R		15U~27U	38
		32U~47U	54
S		15U~27U	24
		32U~47U	28
R2		15U~27U	18
		32U~47U	26
V		20	
V2		17	

2. Fasi di installazione

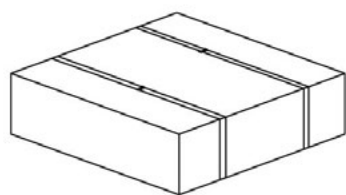

**PARTE SUPERIORE E
INFERIORE - COLLO 1/3**

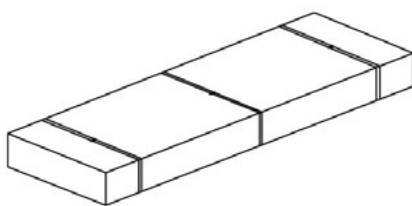

**PORTE ANTERIORE, POSTERIORE
E LATERALI - COLLO 2/3**

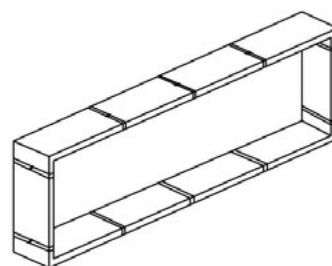

TELAIO - COLLO 3/3

Passo 1. Rimuovere la serratura della porta anteriore (N), le serrature dei pannelli laterali e la serratura del pannello posteriore (O); i componenti si trovano nel collo 1/3. Quindi rimuovere la porta anteriore in vetro (A), il pannello posteriore (B) e i pannelli laterali (C) dal collo 2/3. In questa fase iniziamo montando le serrature sui componenti sopra indicati.

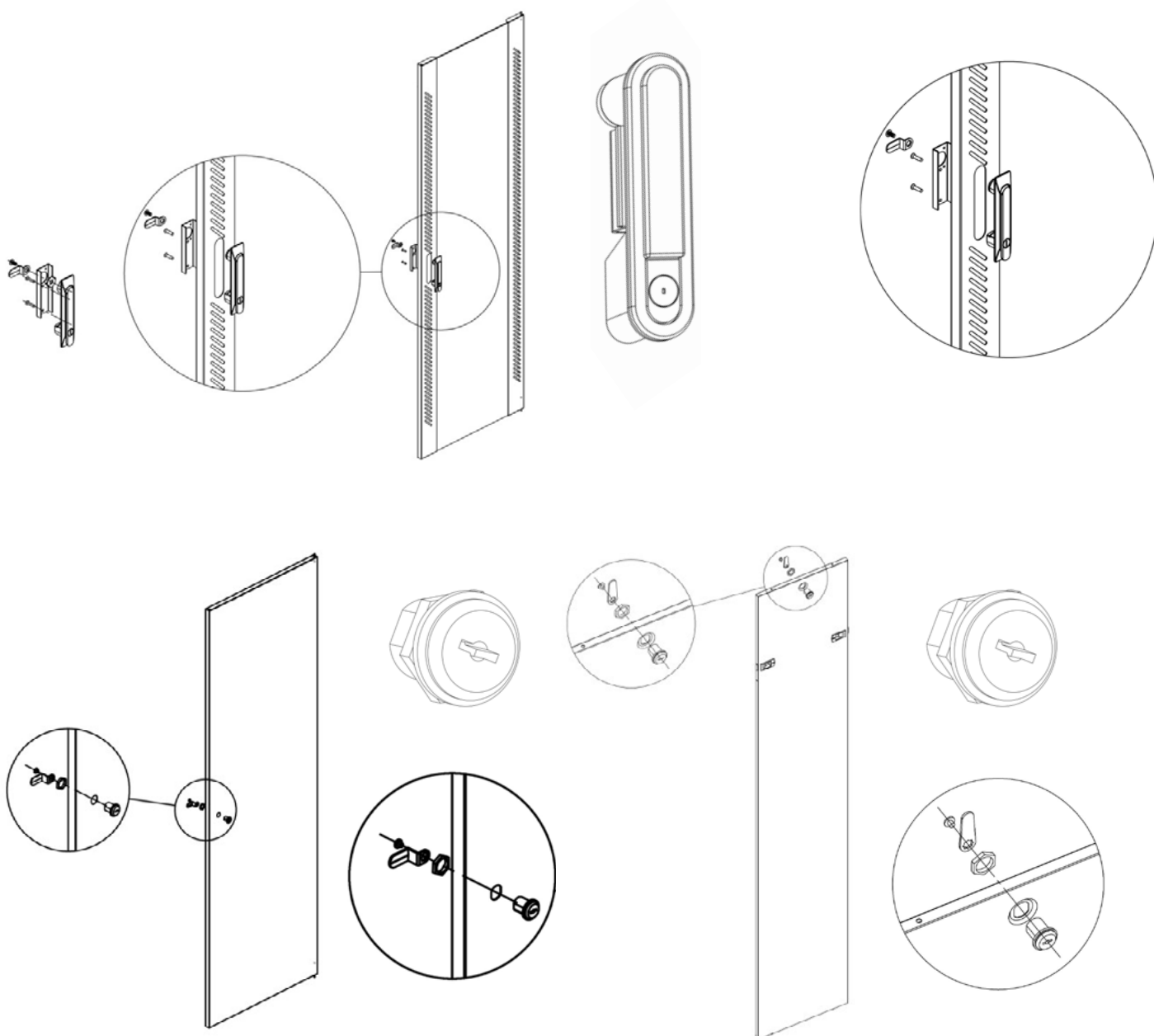

Passo 2. Estrarre le parti del telaio (D) dal collo 3/3. Disporre quindi i telai parallelamente tra loro, con i fori quadrati rivolti verso l'interno. È possibile identificare la parte inferiore del telaio tramite gli elementi di messa a terra.

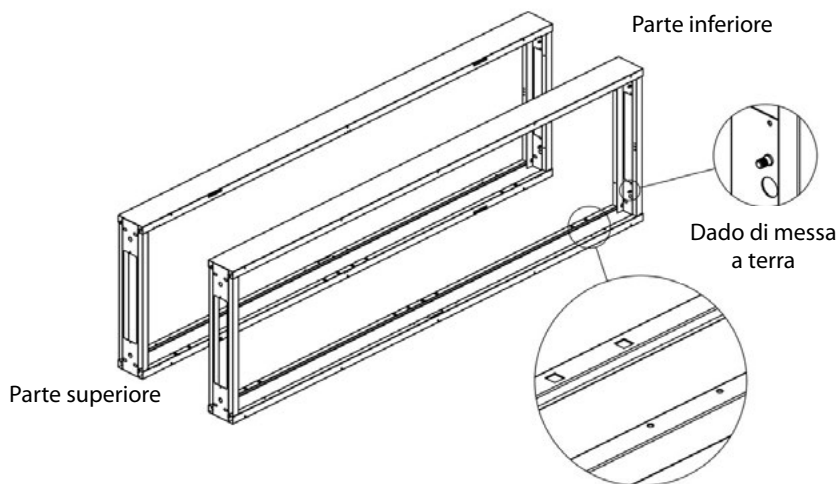

Passo 3. Montare il coperchio superiore (E) sulle parti superiori del telaio (D) e quindi collegarli con una vite a brugola M8 (Q).

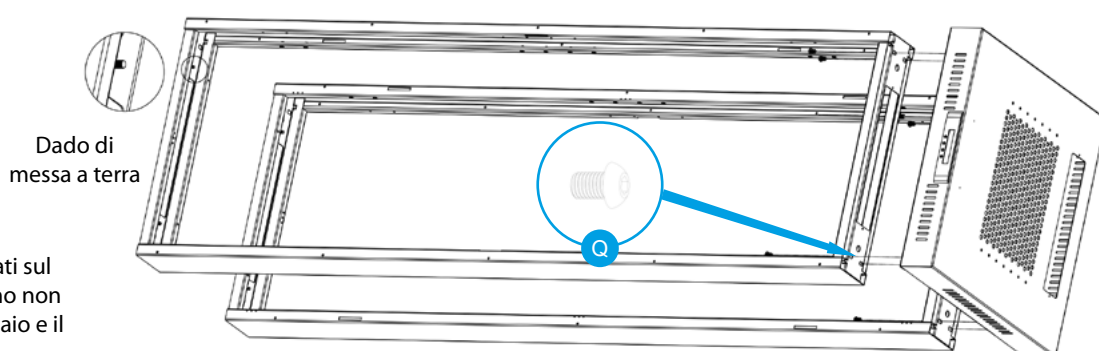

Nota: I telai devono essere montati sul coperchio in modo che dall'interno non vi sia alcuno spazio libero tra il telaio e il coperchio.

Passo 4. Posizionare il coperchio inferiore (F) sulla parte inferiore del telaio (D) e utilizzare la vite a brugola M8 (Q) per collegarli.

Nota: I telai devono essere montati sul coperchio in modo che dall'interno non vi sia alcuno spazio libero tra il telaio e il coperchio.

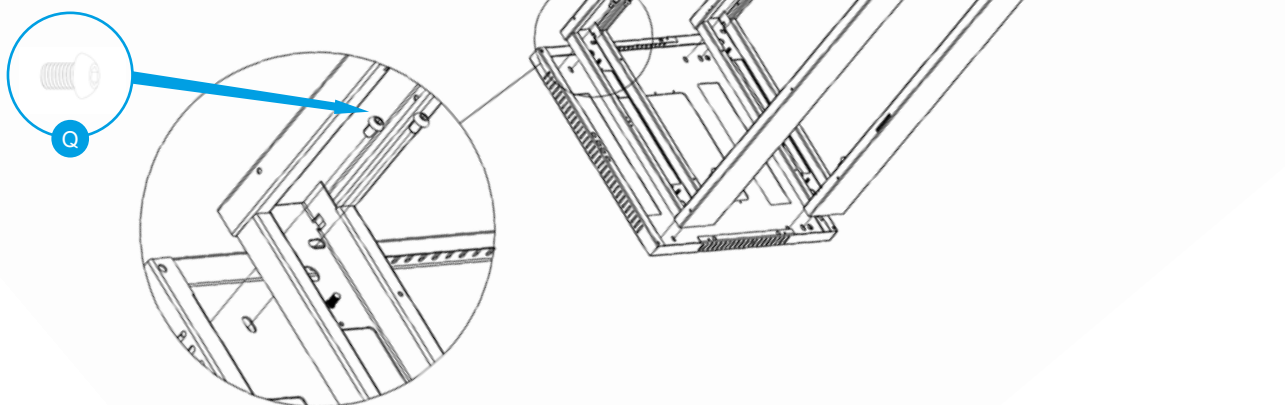

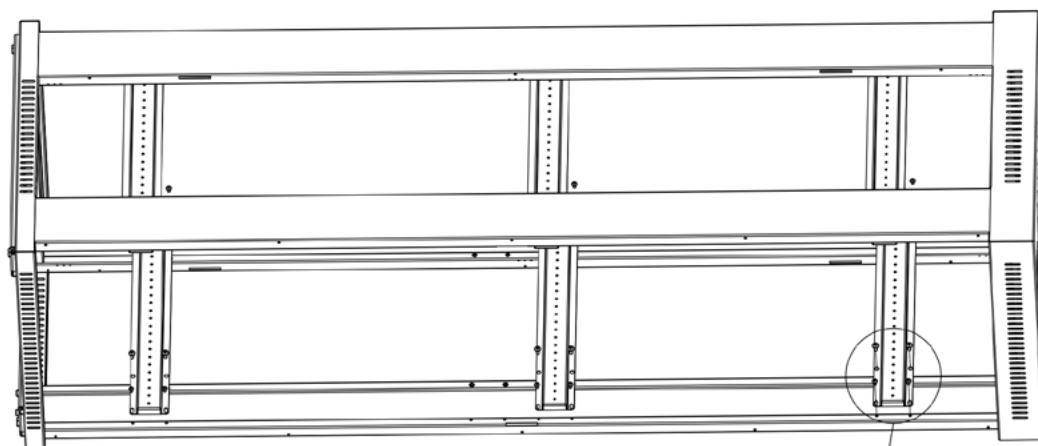

Passo 5. Posizionare la traversa (G) sul telaio (D), evitando il foro destinato alla serratura. Utilizzare una vite M5*10 (R2) e una vite autofilettante M5 (R) per fissare la traversa.

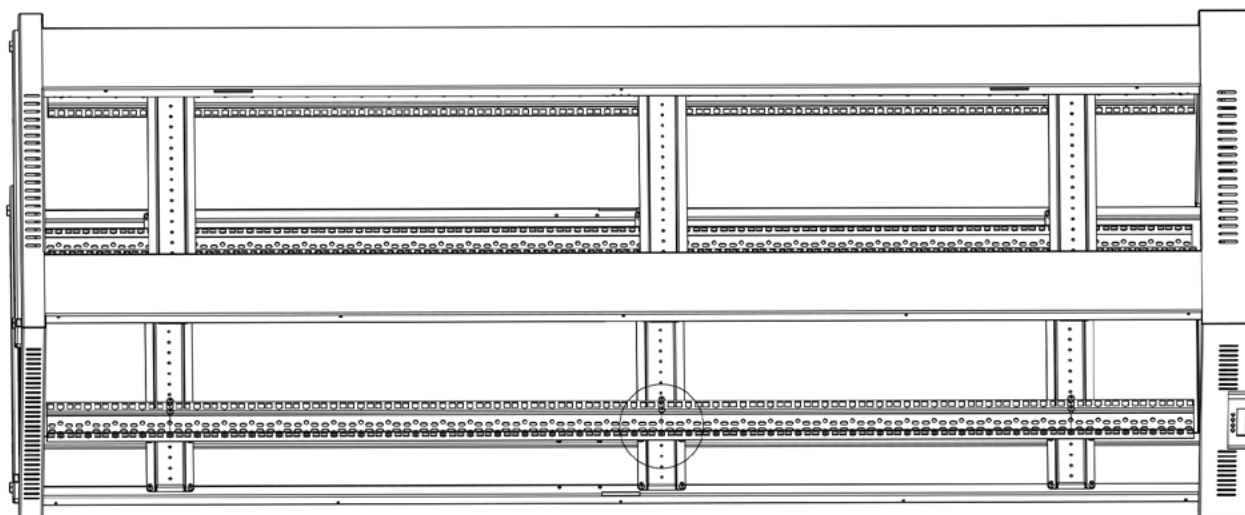
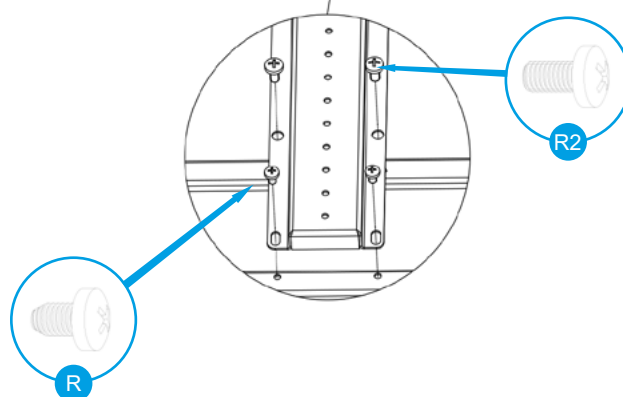

Passo 6. Preparare una vite autofilettante M5*10 (R) per fissare le guide di montaggio verticali (I) alle traverse orizzontali (G).

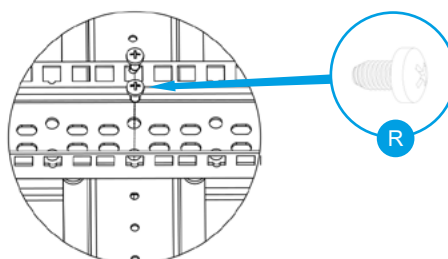

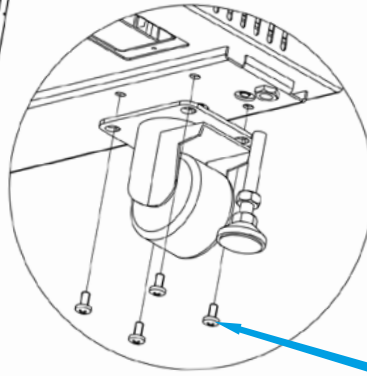
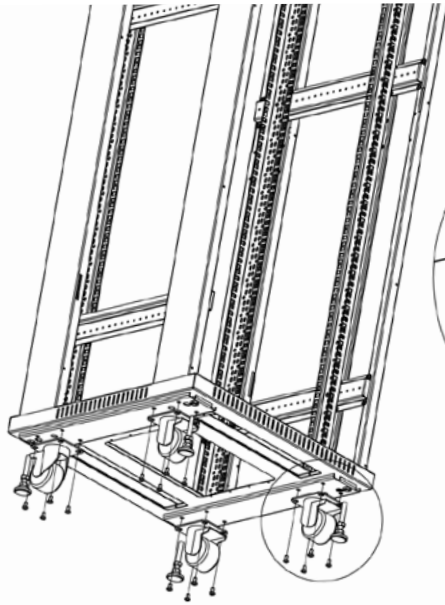

Passo 7. Preparare viti con rondella (V2) per fissare le quattro ruote (L) al coperchio inferiore (F). In alternativa, al posto delle ruote, è possibile fissare al coperchio i piedini (K) inclusi nel kit.

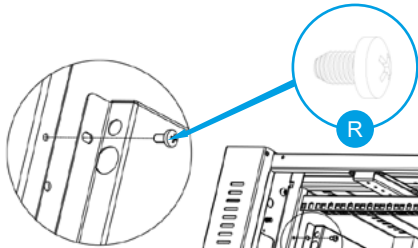
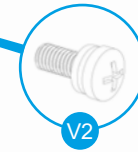

Passo 8. Preparare viti autofilettanti M5 (R) e utilizzarle per fissare il coperchio della ventola (H) al telaio RACK (D).

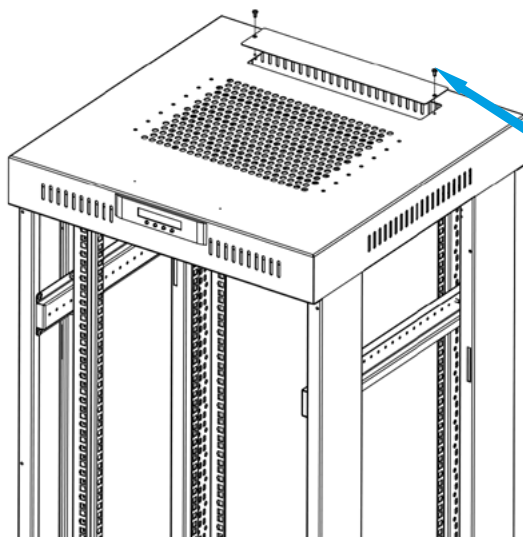
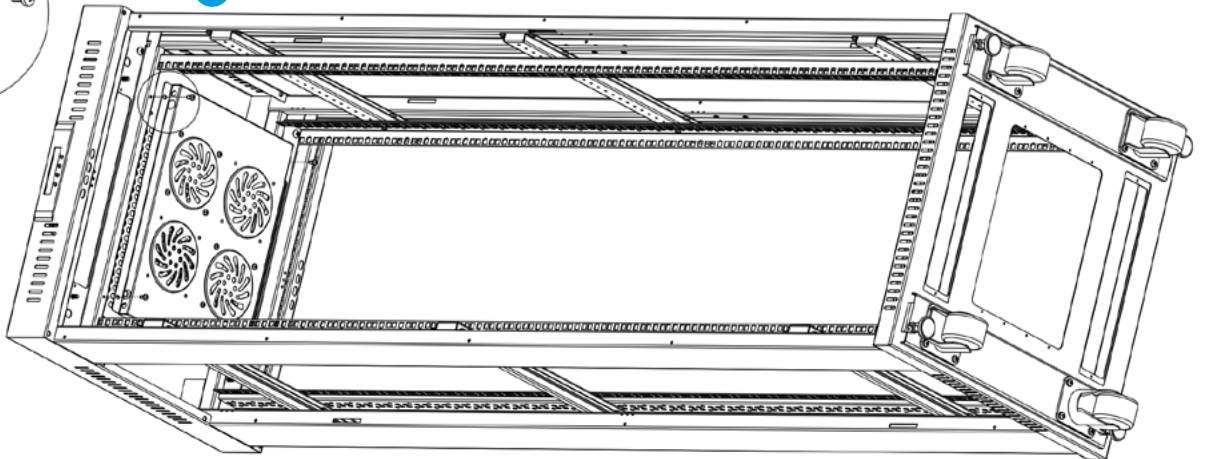

Passo 9. Preparare e utilizzare una vite autofilettante M4 (S) per fissare il coperchio del pannello superiore (J).

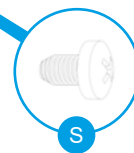

Passo 10. Preparare e utilizzare viti autofilettanti M4 (S) per fissare i fermi porta (M), 12U~27U (8), 32U~47U (12).

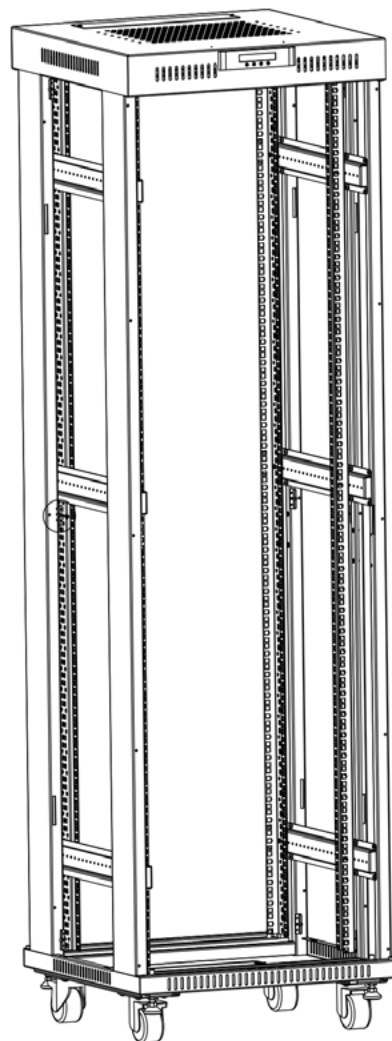
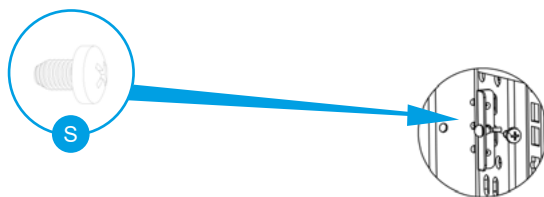

Passo 11. Preparare e posizionare i distanziali delle porte (W) per la porta anteriore e il pannello posteriore (items A e B) nei punti corretti. Montare i pannelli laterali (C) solo alla fine.

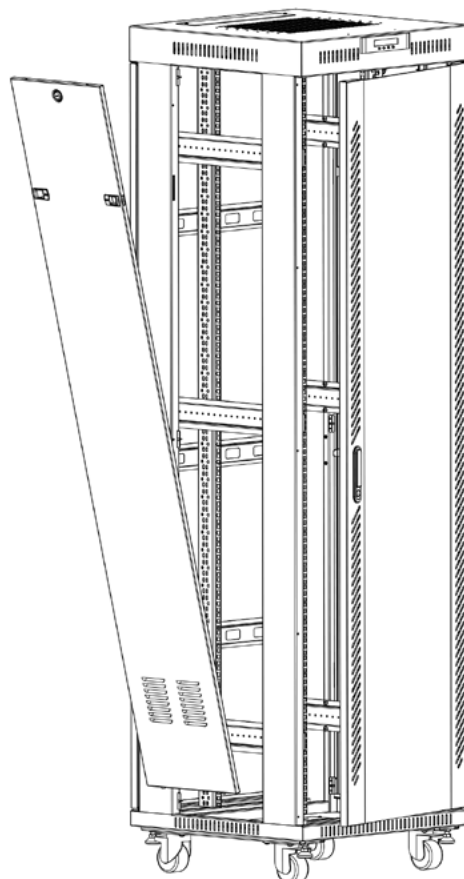
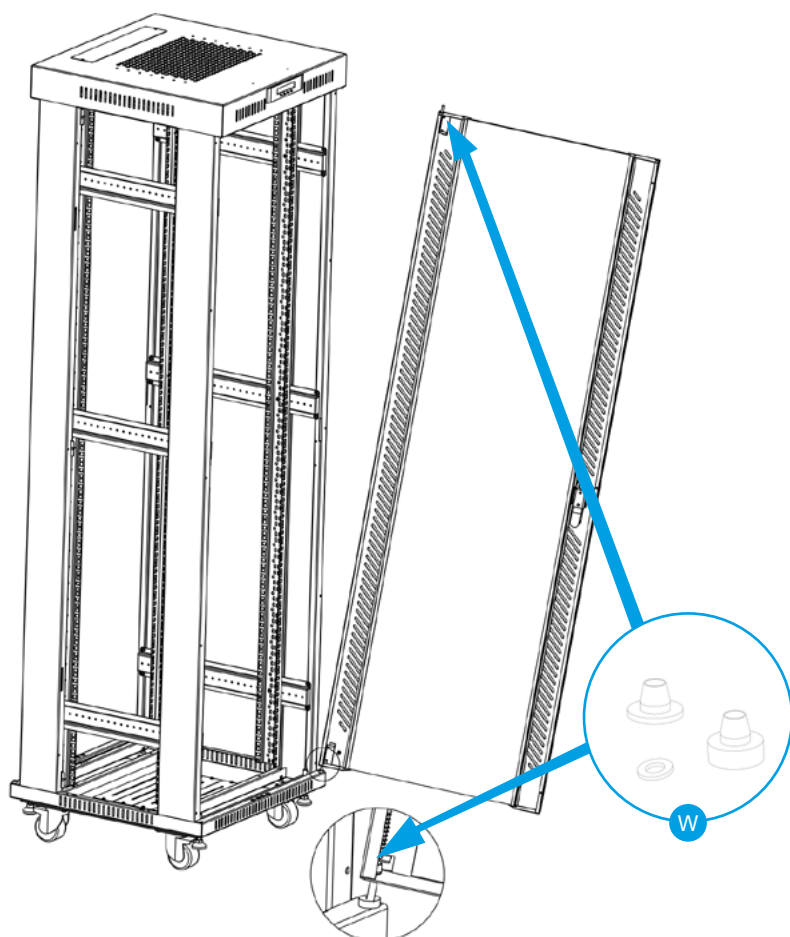











1. Montaż



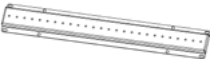
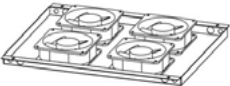

i **Należy ściśle przestrzegać zaleceń zawartych w tej instrukcji.**







1.1 Przygotowanie

Przygotuj odpowiednią ilość miejsca na podłożu na którym odbędzie się montaż. Ostrożnie wyjmij wszystkie elementy z kartonu transportowego. Dalsze instrukcje montażu będą opierać się o zawarty schemat.

1.1.1. Zestawienie elementów

Części szafy		
Nr elementu	Rysunek elementu	Liczba w zestawie
Element A		1
Element B		1
Element C		2
Element D		2
Element E		1
Element F		1
Element G		15U~27U 4 32U~47U 6
Element H		1
Element I		4
Element J		3 4
Element K		4

Element L		4
Element M		15U~27U 8 32U~47U 12
Element N		1
Element O		3
Element W		4

Śruby			
Nr. elementu	Rysunek elementu	Liczba w zestawie	
Element Q		17	
Element R		15U~27U	38
		32U~47U	54
Element S		15U~27U	24
		32U~47U	28
Element R2		15U~27U	18
		32U~47U	26
Element V		20	
Element V2		17	

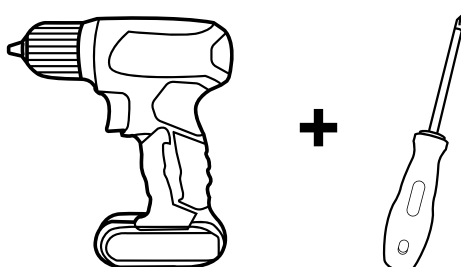

2. Etapy montażu

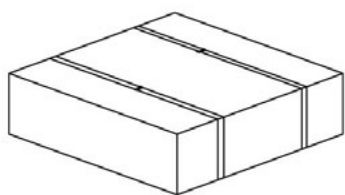

PAKIET GÓRA I DÓŁ 1/3

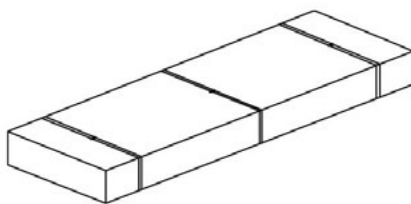

PAKIET DRZWI PRZEDNIE,
TYLNE I BOCZNE 2/3

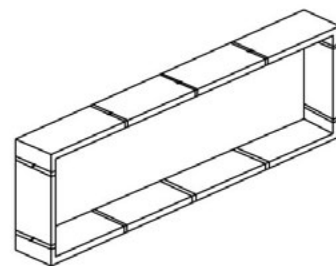

PAKIET RAMY 3/3

Krok 1. Wyjmij zamek drzwi przednich (N), zamek paneli bocznych oraz panelu tylnego (O), elementy znajdują się w opakowaniu 1/3. Następnie wyjmij przednie szklane drzwi (A), tylne drzwi stalowe (B) oraz panele boczne (C) z opakowania 2/3. Na tym etapie zaczynamy montaż zamków do podanych elementów.

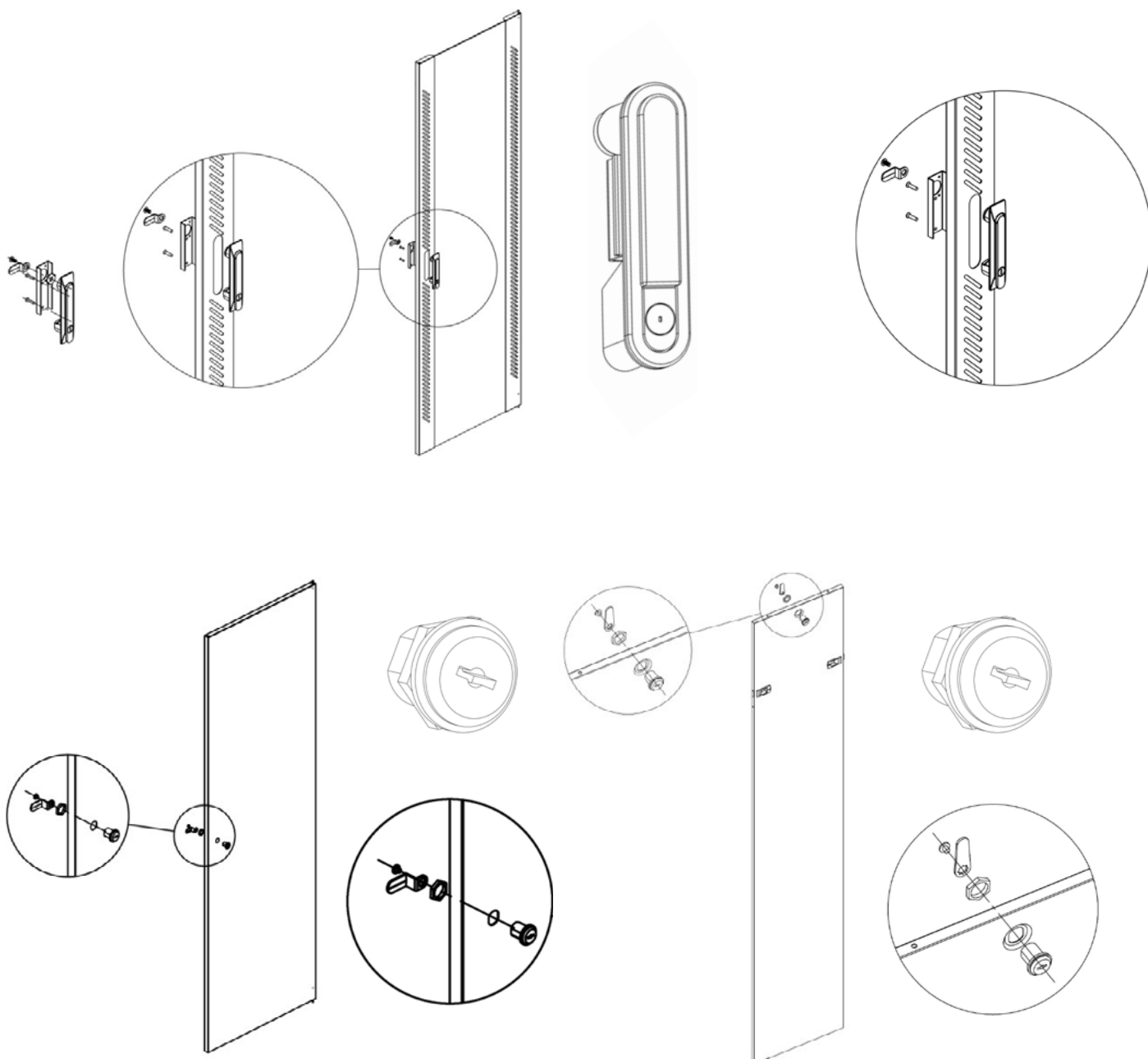

Krok 2. Rozpakuj elementy ramy (J) z opakowania 3/3. Następnie ułóż ramy równoległe, z otworami z nitonakrętek skierowanymi do wewnątrz, do siebie. Dolną część ramy rozpoznasz po elemencie do zamontowania uziemienia.

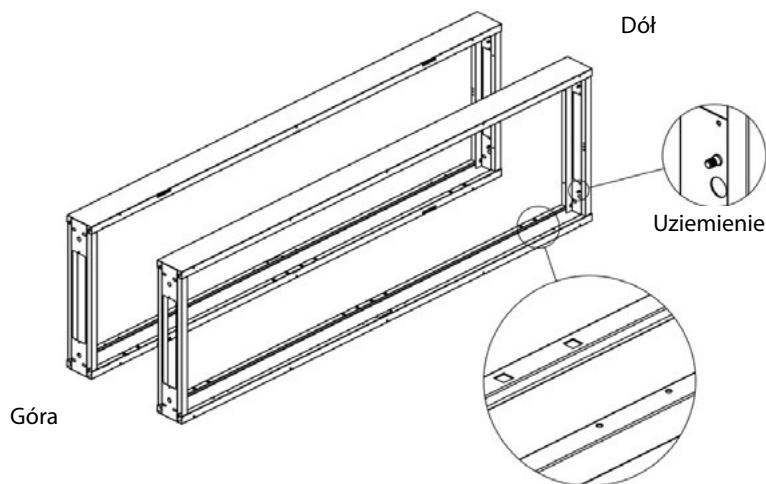

Krok 3. Nałóż górną pokrywę (E) na górną część ramy (D), a następnie połącz je śrubą imbusową M8 (Q).

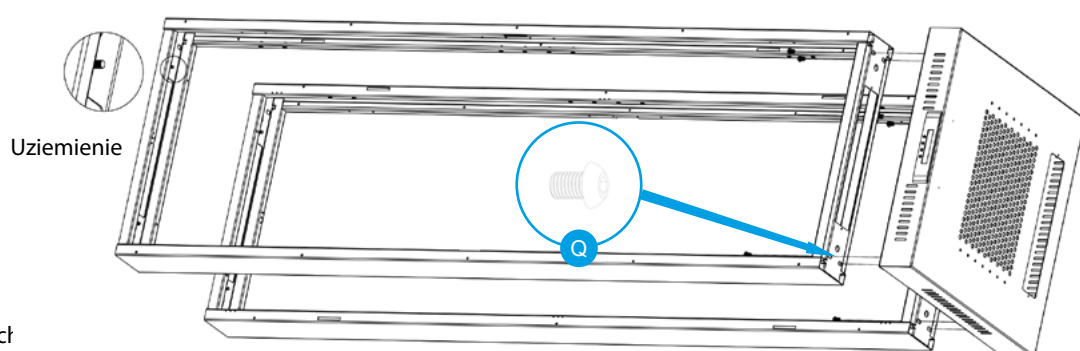

Uwaga: Ramy powinny być zamontowane na pokrywie w taki sposób, aby nie pozostawiać wolnych szczelin pomiędzy ramą a pokrywą od wewnątrz.

Krok 4. Umieść dolną pokrywę (element F) na dolnej części ramy (D), a następnie połącz je za pomocą śruby imbusowej M8 (Q).

Uwaga: Ramy powinny być zamontowane na pokrywie w taki sposób, aby nie pozostawiać wolnych szczelin pomiędzy ramą a pokrywą od wewnątrz.

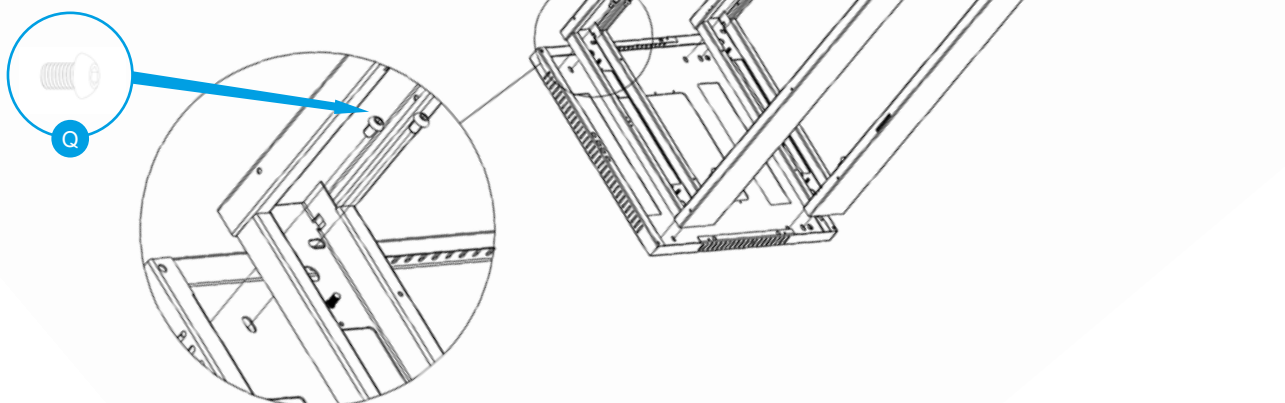

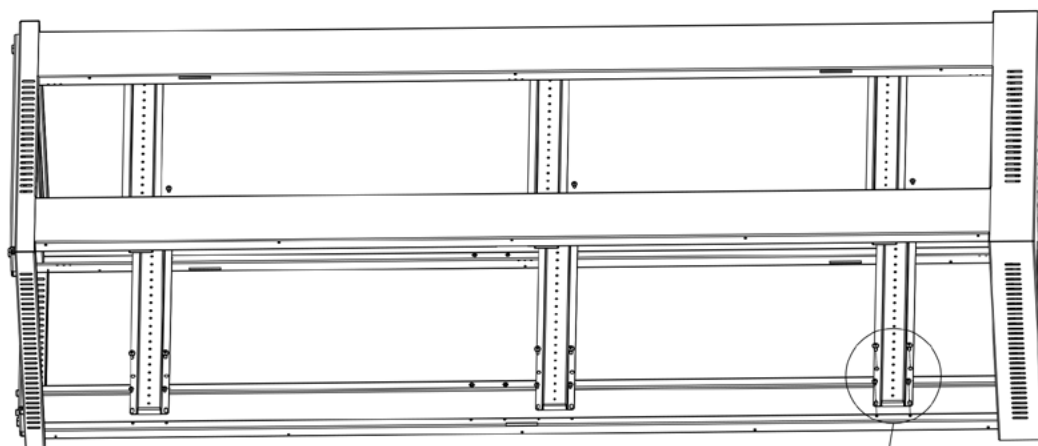

Krok 5. Umieść poprzeczkę (G) na ramie (D), omijając otwór w ramie przygotowany dla zamka! Następnie użyj śruby M5*10 (R2) oraz samo-gwintującej śruby M5 (R) do przymocowania poprzeczki.

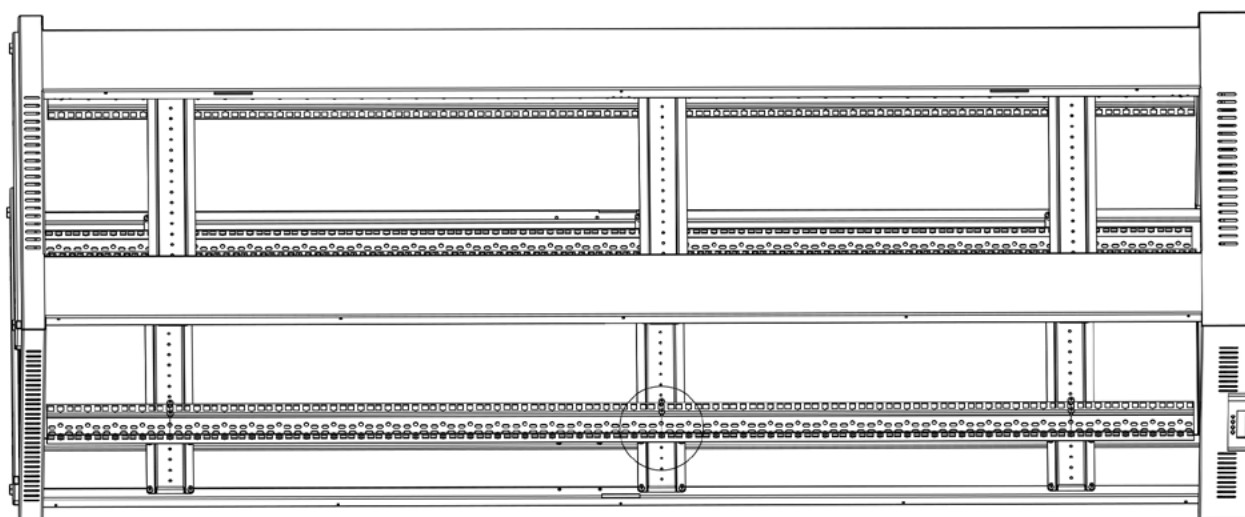
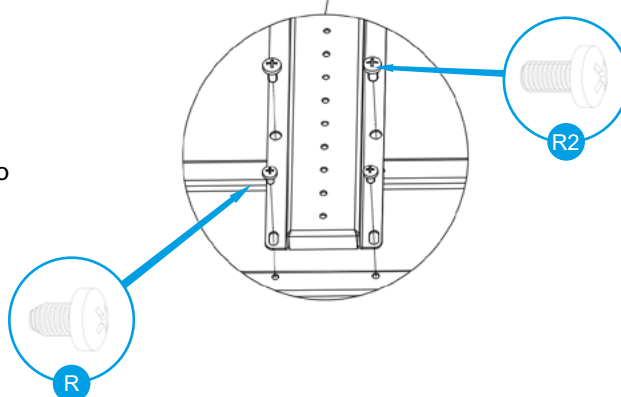

Krok 6. Przygotuj samogwintujące wkręty M5*10 (R) do zamocowania pionowych szyn montażowych (I) do poziomych poprzeczek (G).

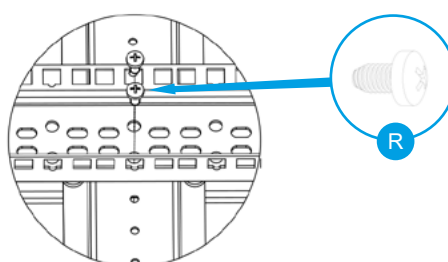

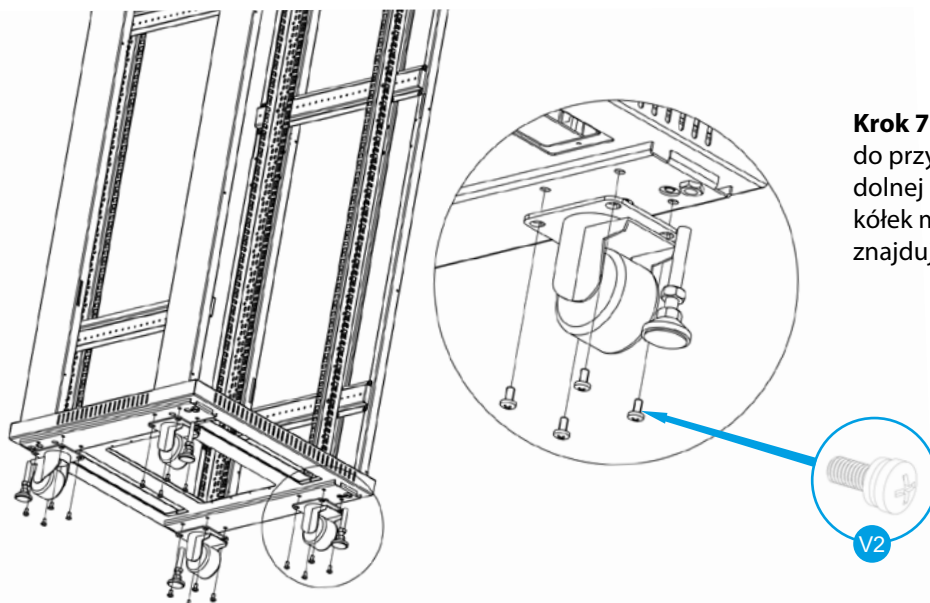

Krok 7. Przygotuj śruby z podkładkami (V2) do przymocowania czterech kółek (L) do dolnej pokrywy (F). Alternatywnie, zamiast kółek możesz przymocować nóżki (K) znajdujące się w zestawie.

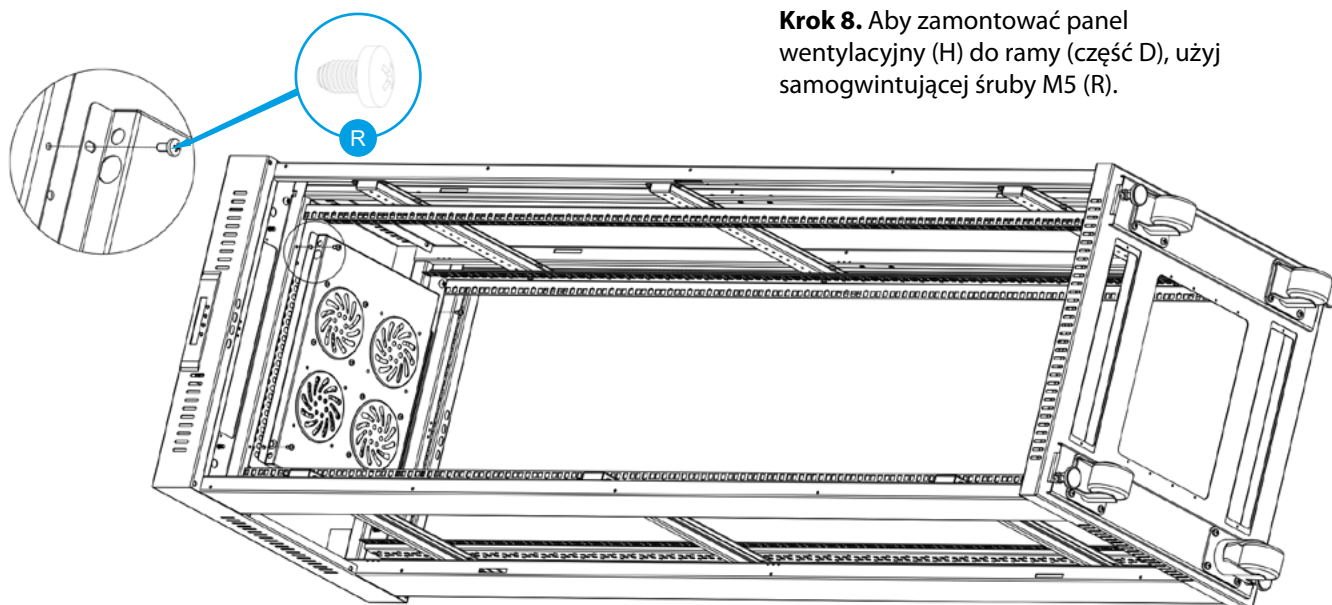

Krok 8. Aby zamontować panel wentylacyjny (H) do ramy (część D), użyj samogwintującej śruby M5 (R).

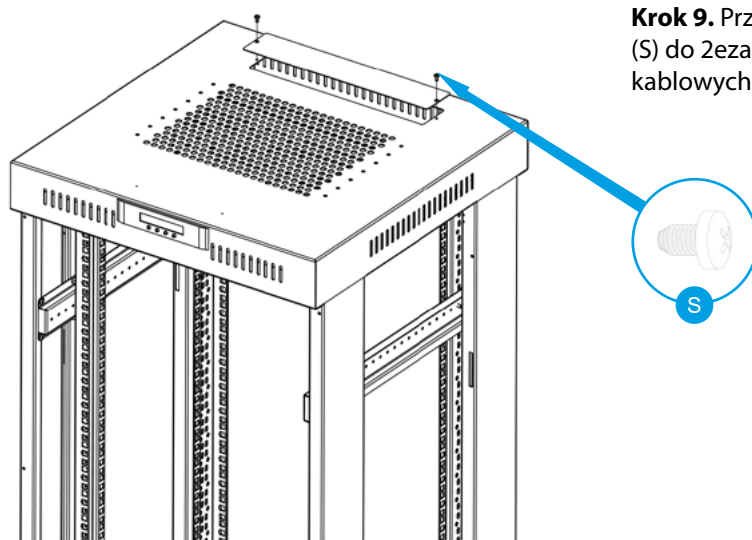

Krok 9. Przygotuj wkręty samogwintujące M4 (S) do zezamocowania zaślepek (J) otworów kablowych górnego i dolnego panelu.

Krok 10. Przygotuj wkręty samogwintujące M4 (S), aby zamocować stopery do drzwi (M). Dla rozmiarów 12U~27U (8szt), 47U~42U (12).

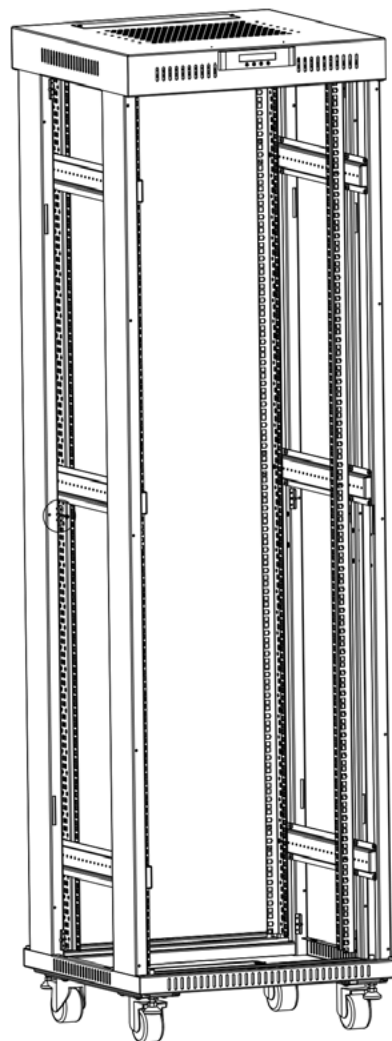
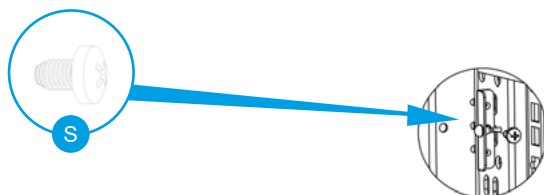

Krok 11. Przygotuj i umieść w odpowiednim miejscu dystanse drzwi (W) dla przednich drzwi oraz tylnych (A i B). Boczne panele (C) załóż na samym końcu.

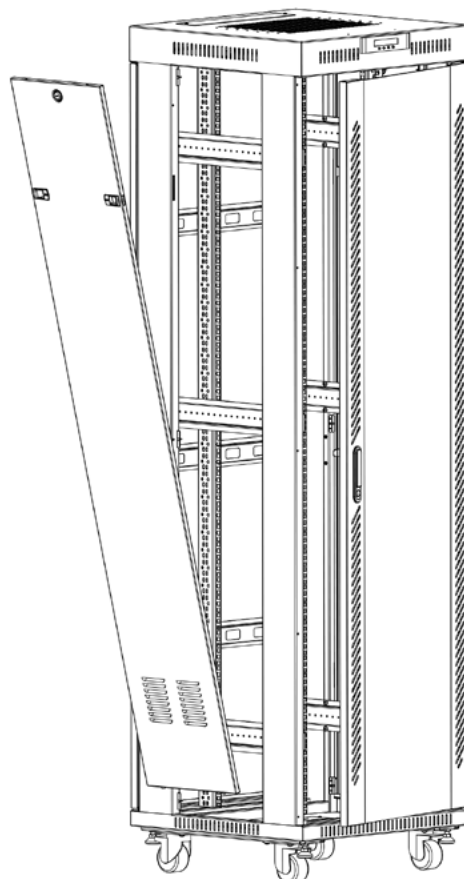
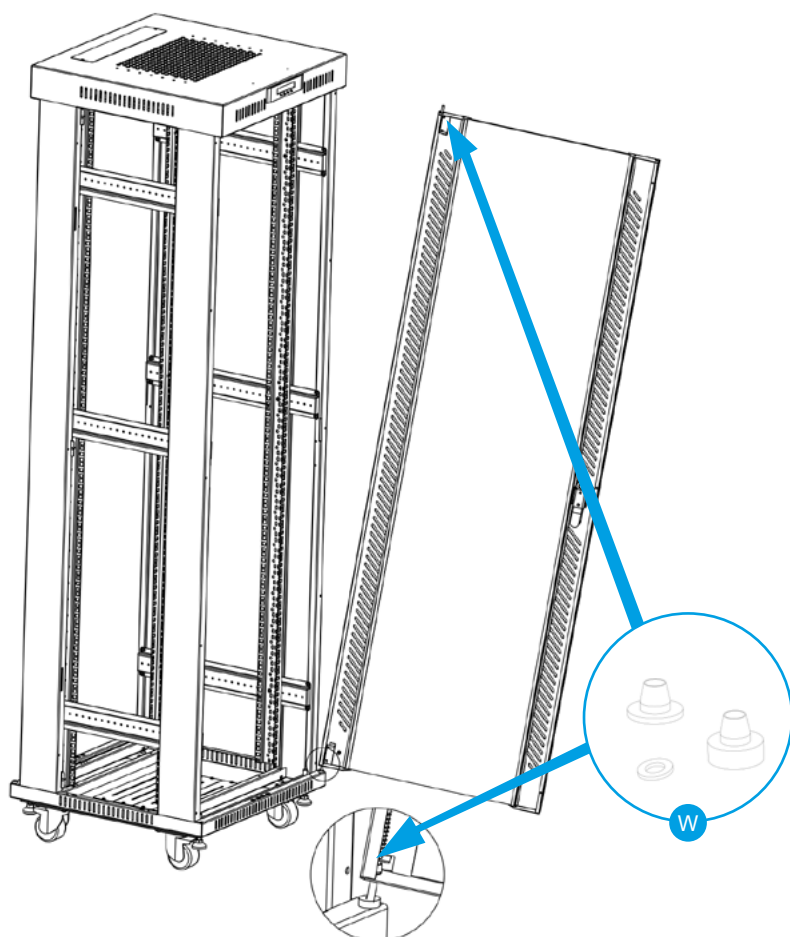









1. Montáž





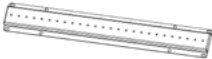
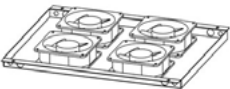

Dbejte na to, abyste přísně dodržovali pokyny uvedené v tomto návodu.







1.1 Příprava

Připravte dostatečné množství volného prostoru na ploše, na které bude montáž probíhat. Opatrně vyjměte všechny prvky z přepravní krabice. Další pokyny k montáži budou vycházet z přiloženého schématu.

1.1.1. Tabulka komponentů

Díly skříně		
Č. položky	Nákres	Dodané množství
A		1
B		1
C		2
D		2
E		1
F		1
G		15U~27U 4 32U~47U 6
H		1
I		4
J		3 4

K		4
L		4
M		15U~27U 8 32U~47U 12
N		1
O		3
W		4

Šrouby			
Č. položky	Nákres	Dodané množství	
Q		17	
R		15U~27U	38
		32U~47U	54
S		15U~27U	24
		32U~47U	28
R2		15U~27U	18
		32U~47U	26
V		20	
V2		17	

2. Kroky instalace

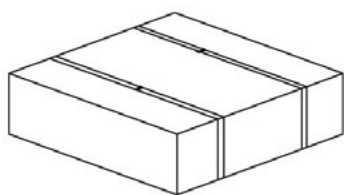

HORNÍ A DOLNÍ ČÁST - BALENÍ
1/3

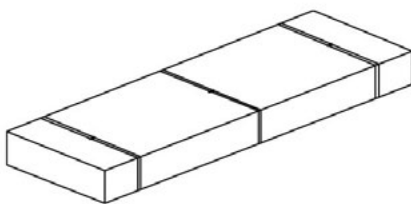

PŘEDNÍ, ZADNÍ A BOČNÍ DVEŘE -
BALENÍ 2/3

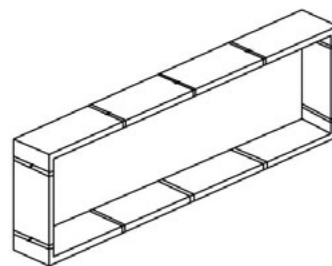

RÁM - BALENÍ 3/3

Krok 1. Odstraňte zámek předních dveří (N), zámky bočních panelů a zámek zadního panelu (O); součásti se nacházejí v balení 1/3. Poté vyjměte přední skleněné dveře (A), zadní panel (B) a boční panely (C) z balení 2/3. V této fázi začínáme montáží zámků na výše uvedené součásti.

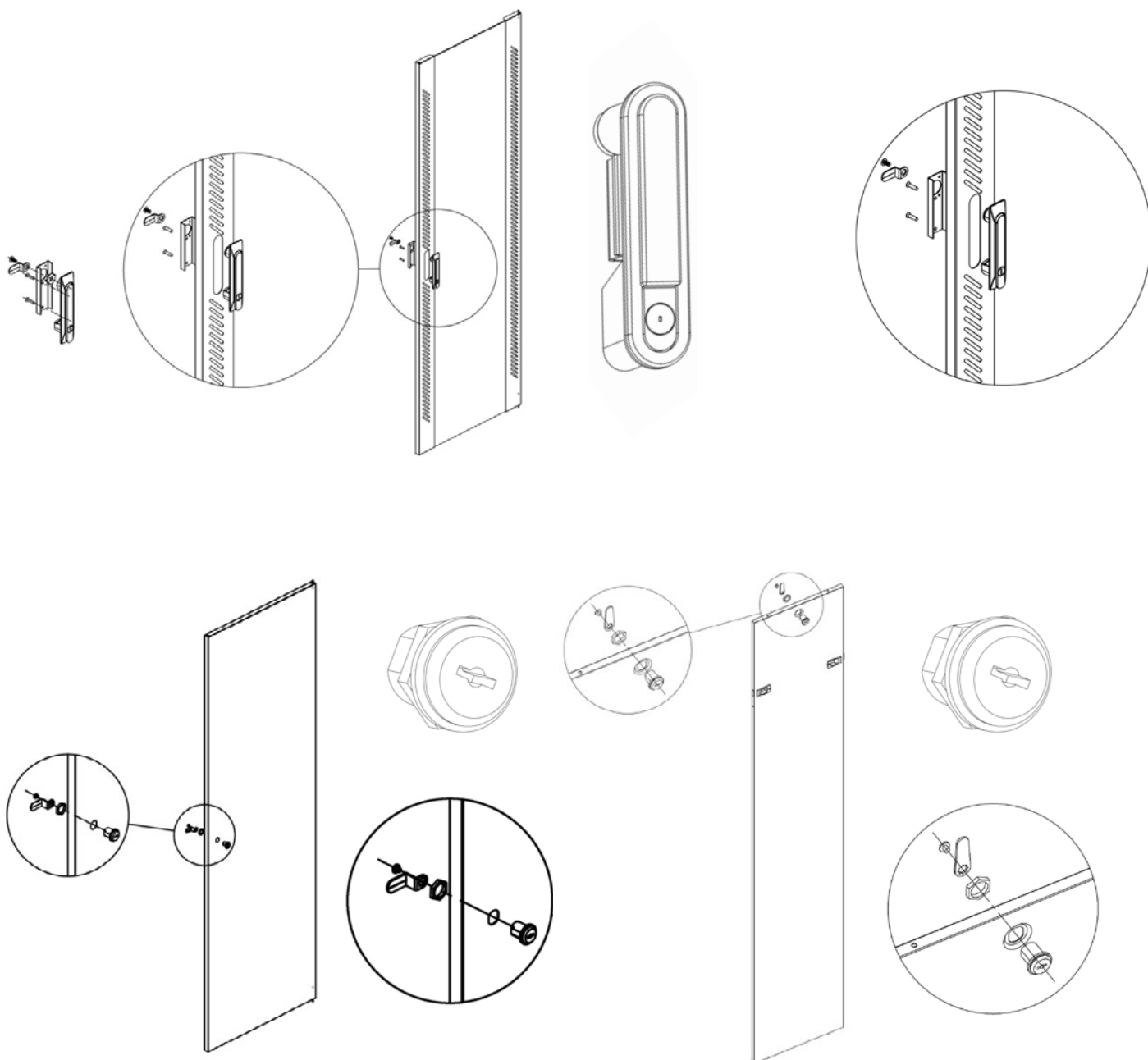

Krok 2. Vybalte části rámu (D) z balení 3/3. Poté uspořádejte rámy rovnoběžně vedle sebe tak, aby čtvercové otvory směřovaly dovnitř. Spodní část rámu poznáte podle uzemňovacích prvků.

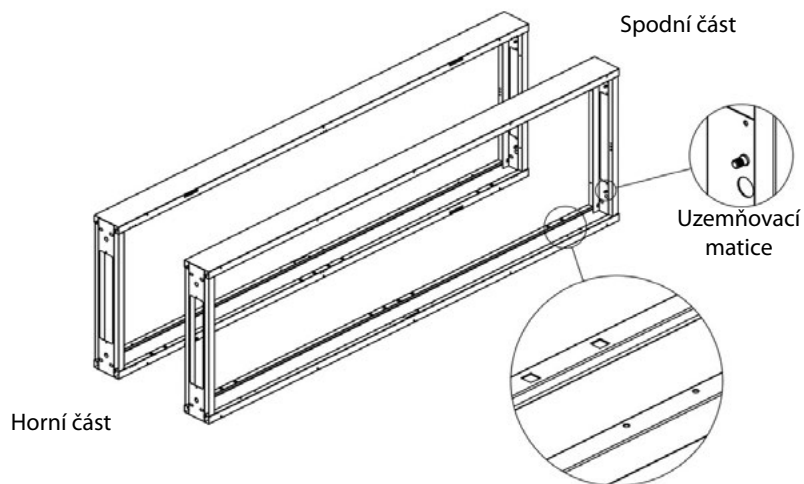

Krok 3. Připevněte horní kryt (E) k horním částem rámu (D) a poté je spojte šroubem s vnitřním šestihranem M8 (Q).

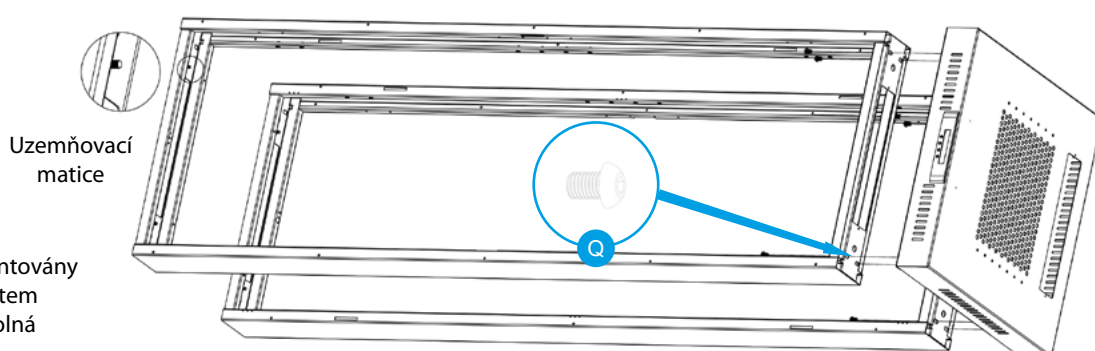

Poznámka: Rámy musí být namontovány na kryt tak, aby mezi rámem a krytem z vnitřní strany nevznikla žádná volná mezera.

Krok 4. Umístěte spodní kryt (F) na spodní část rámu (D) a použijte šroub s vnitřním šestihranem M8 (Q) k jejich spojení.

Poznámka: Rámy musí být namontovány na kryt tak, aby mezi rámem a krytem z vnitřní strany nevznikla žádná volná mezera.

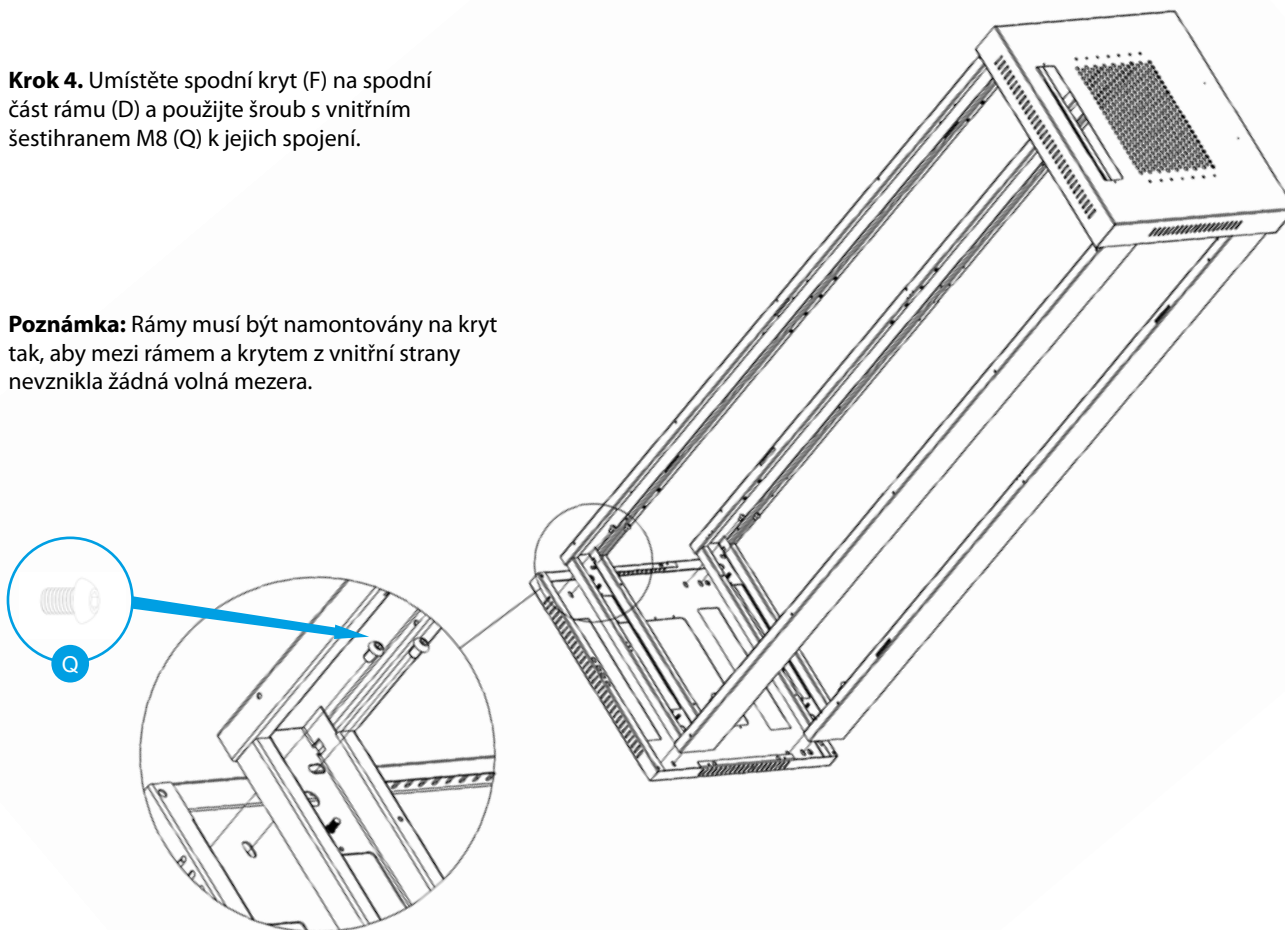

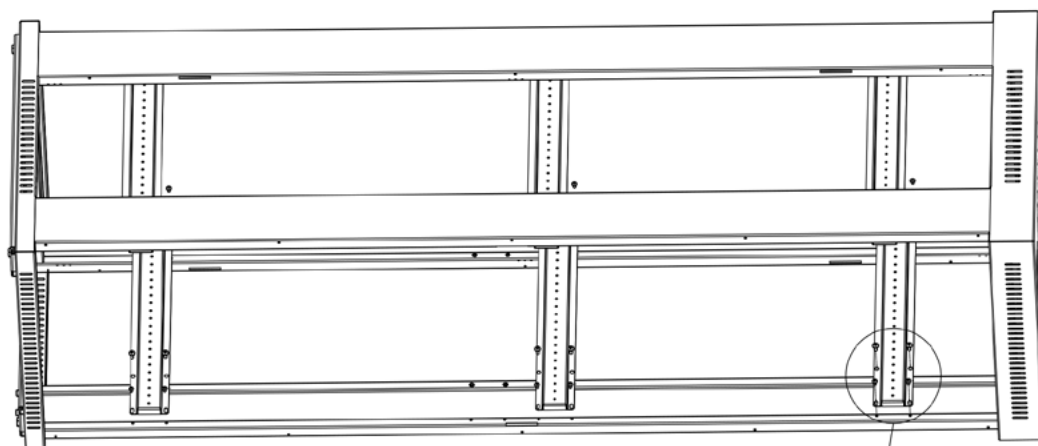

Krok 5. Umístěte příčník (G) na rám (item D) tak, abyste se vyhnuli otvoru určenému pro zámek. K upevnění příčníku použijte šroub M5*10 (R2) a samořezný šroub M5 (R).

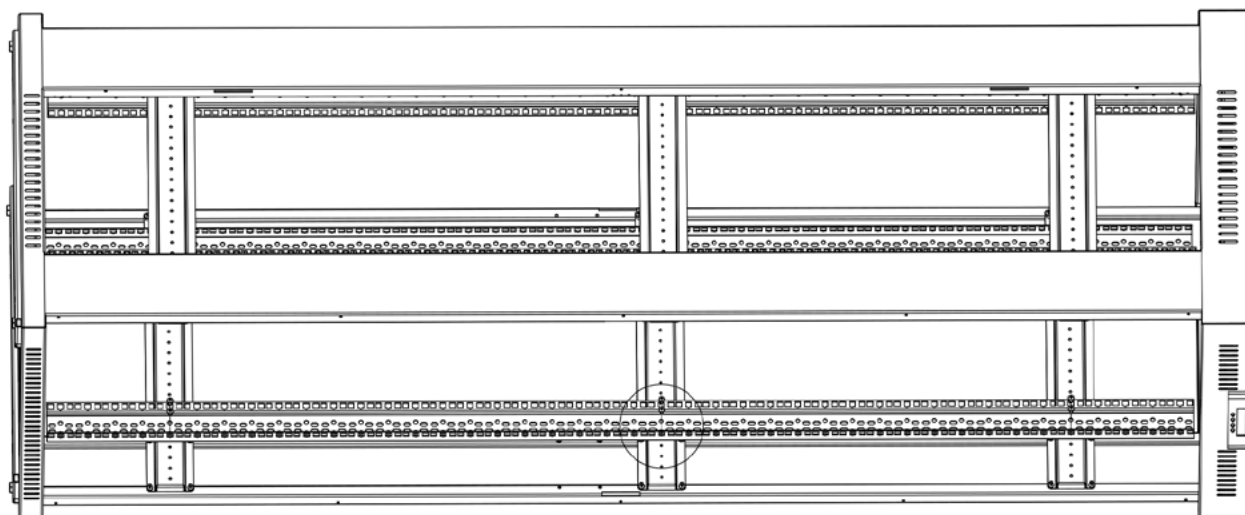
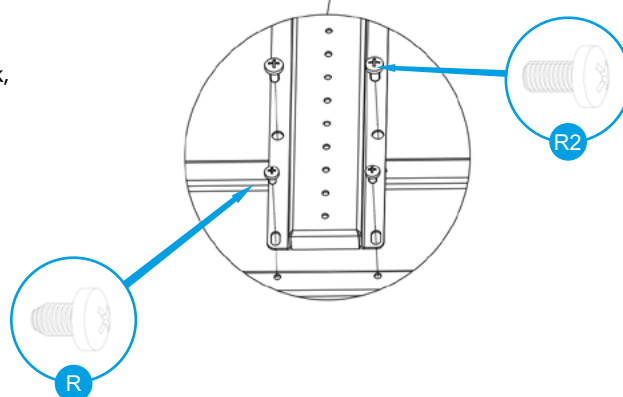

Krok 6. Připravte samořezný šroub M5*10 (R) k upevnění vertikálních montážních lišt (I) k vodorovným příčkám (G).

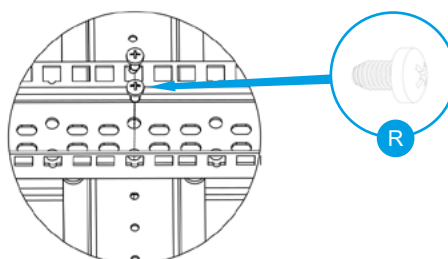

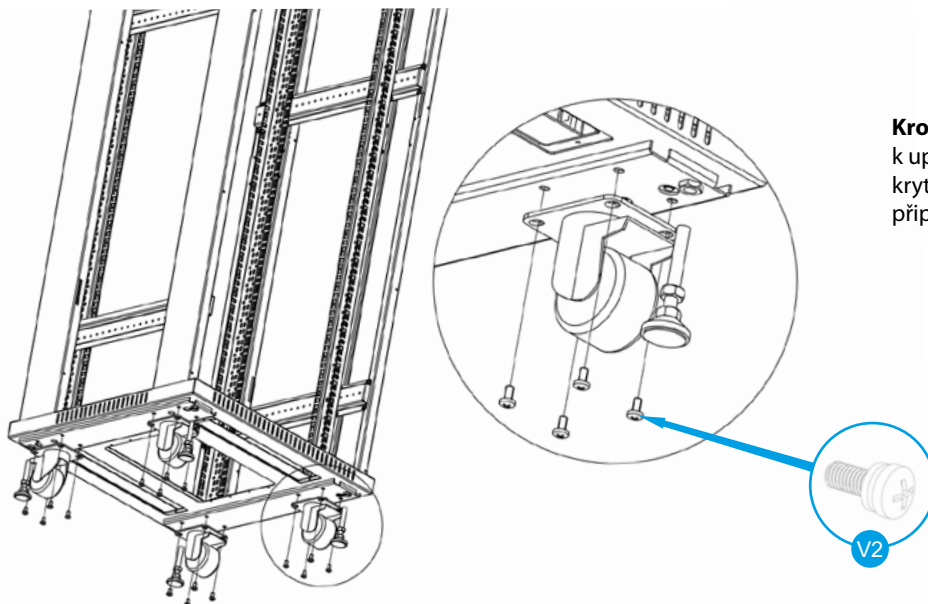

Krok 7. Připravte šrouby s podložkou (V2) k upevnění čtyř koleček (L) ke spodnímu krytu (F). Místo koleček můžete ke krytu připevnit nožky (K), které jsou součástí sady.

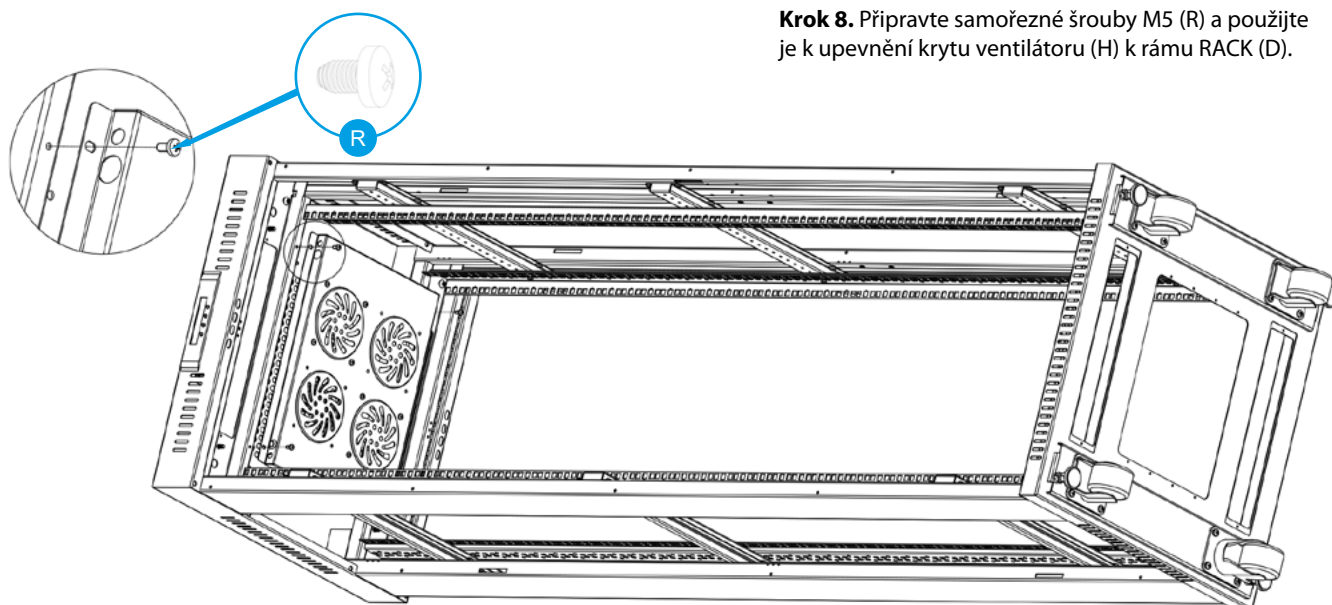

Krok 8. Připravte samořezné šrouby M5 (R) a použijte je k upevnění krytu ventilátoru (H) k rámu RACK (D).

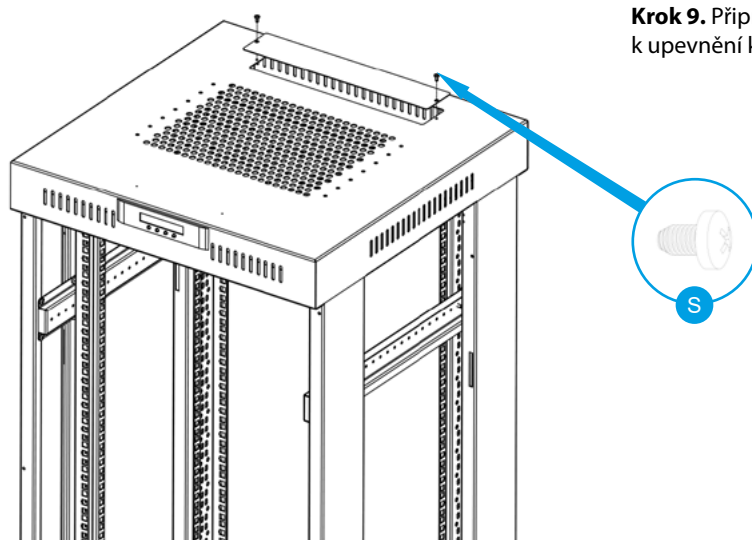

Krok 9. Připravte a použijte samořezný šroub M4 (S) k upevnění krytky horního panelu (J).

Krok 10. Připravte a použijte samořezné šrouby M4 (S) k upevnění dorazů dveří (M), 12U~27U (8), 32U~47U (12).

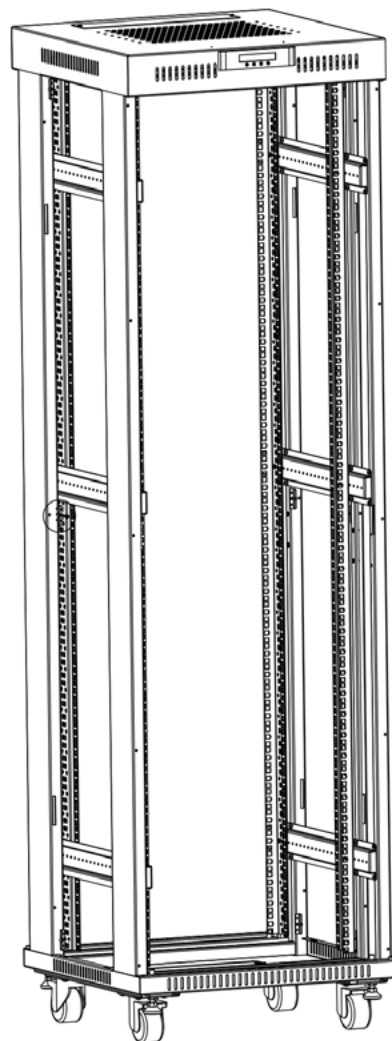

Krok 11. Připravte a umístěte rozpěrky dveří (W) pro přední dveře a zadní panel (A a B) na správná místa. Boční panely (C) namontujte až úplně nakonec.

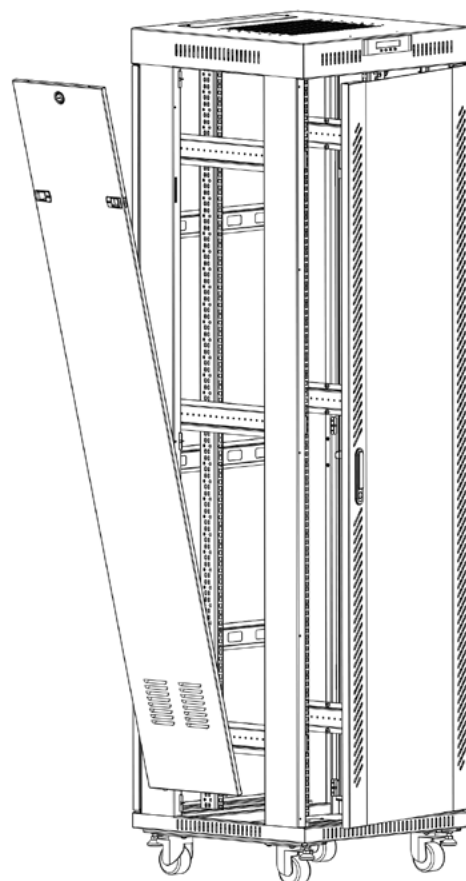
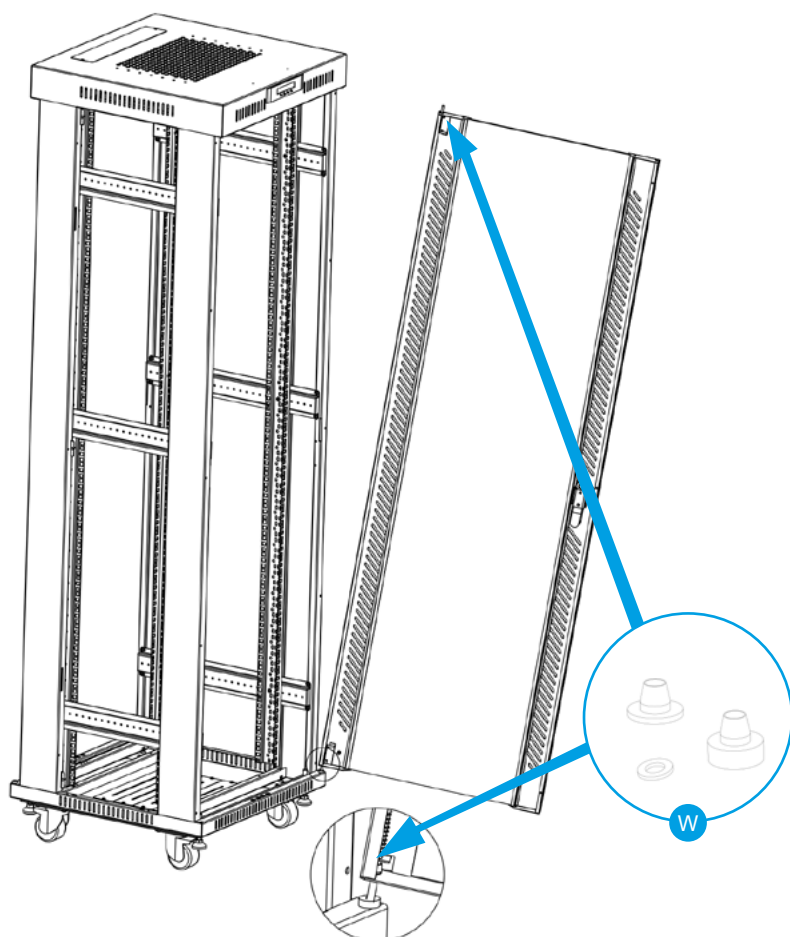









1. Montáž





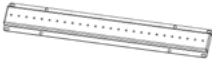
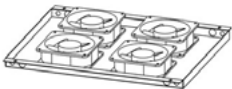

Dbajte na to, aby ste prísne dodržiavali pokyny uvedené v tomto návode.







1.1 Príprava

Prípravte dostatočné množstvo voľného priestoru na povrchu, na ktorom bude montáž prebiehať. Opatrne vyberte všetky prvky z prepravnej krabice. Ďalšie pokyny na montáž budú vychádzať z priloženého diagramu

1.1.1. Tabuľka komponentov

Diely skrine		
Č. položky	Nákres	Dodané množstvo
A		1
B		1
C		2
D		2
E		1
F		1
G		15U~27U 4 32U~47U 6
H		1
I		4
J		3 4

K		4
L		4
M		15U~27U 8 32U~47U 12
N		1
O		3
W		4

Skrutky			
Č. položky	Nákres	Dodané množství	
Q		17	
R		15U~27U	38
		32U~47U	54
S		15U~27U	24
		32U~47U	28
R2		15U~27U	18
		32U~47U	26
V		20	
V2		17	

2. Kroky inštalácie

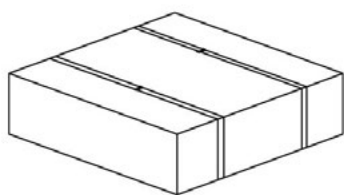

**HORNÁ A DOLNÁ ČASŤ -
BALENIE 1/3**

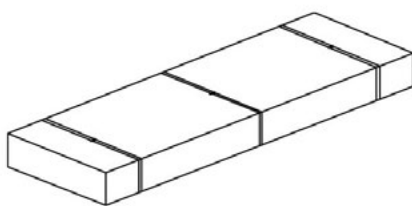

**PREDNÉ, ZADNÉ A BOČNÉ DVERE
- BALENIE 2/3**

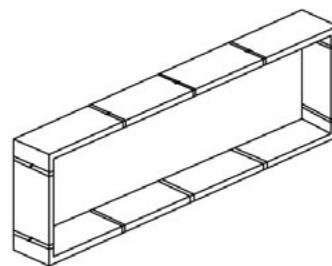

RÁM - BALENIE 3/3

Krok 1. Odstráňte zámok predných dverí (N), zámky bočných panelov a zámok zadného panelu (O); súčasti sa nachádzajú v balení 1/3. Potom vyberte predné sklenené dvere (A), zadný panel (B) a bočné panely (C) z balenia 2/3. V tejto fáze začíname montážou zámkov na vyššie uvedené súčasti.

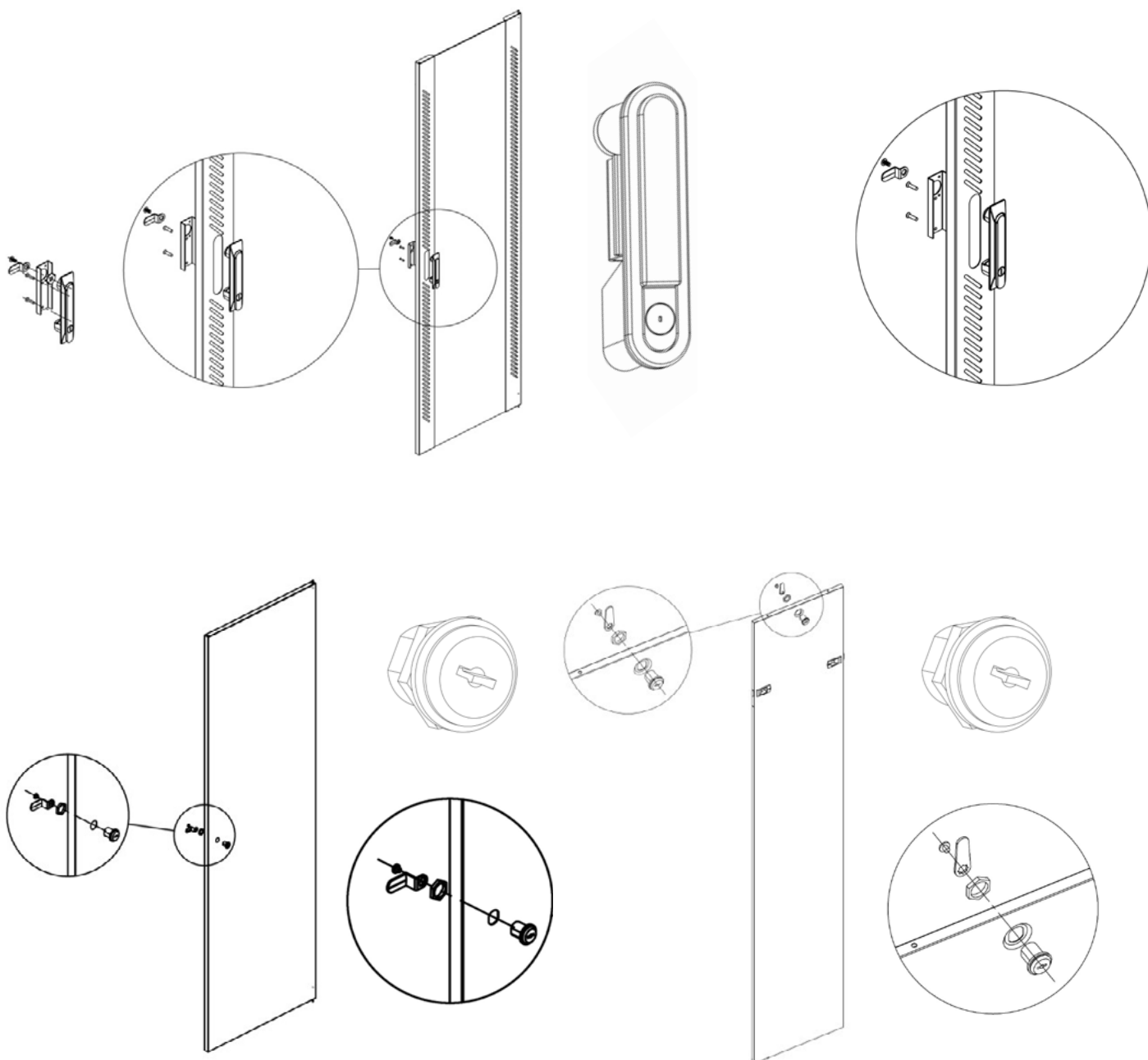

Krok 2. Vybalte časti rámu (D) z balenia 3/3. Potom usporiadajte rámy rovnobežne vedľa seba tak, aby štvorcové otvory smerovali dovnútra. Spodnú časť rámu rozpoznáte podľa uzemňovacích prvkov.

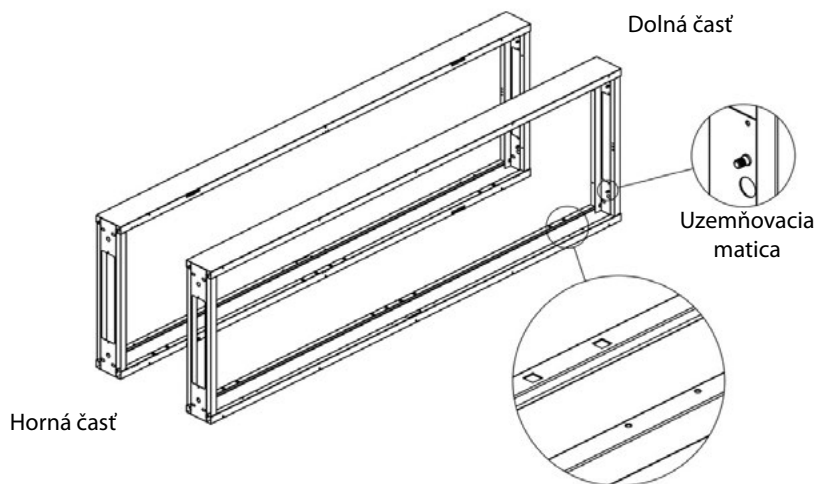

Krok 3. Pripevnite horný kryt (E) k horným častiam rámu (D) a potom ich spojte skrutkou s vnútorným šesťhranom M8 (Q).

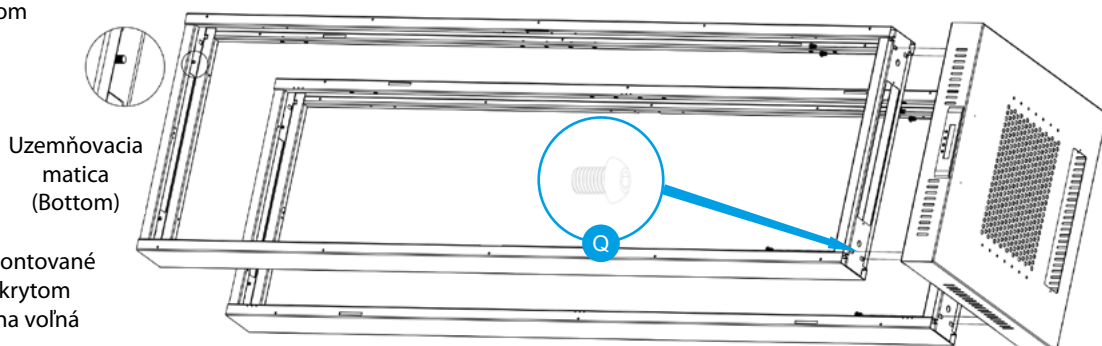

Poznámka: Rámy musia byť namontované na kryte tak, aby medzi rámom a krytom z vnútornej strany nevznikla žiadna voľná medzera.

Krok 4. Umiestnite spodný kryt (F) na spodnú časť rámu (D) a použite skrutku s vnútorným šesťhranom M8 (Q) na ich spojenie.

Poznámka: Rámy musia byť namontované na kryte tak, aby medzi rámom a krytom z vnútornej strany nevznikla žiadna voľná medzera.

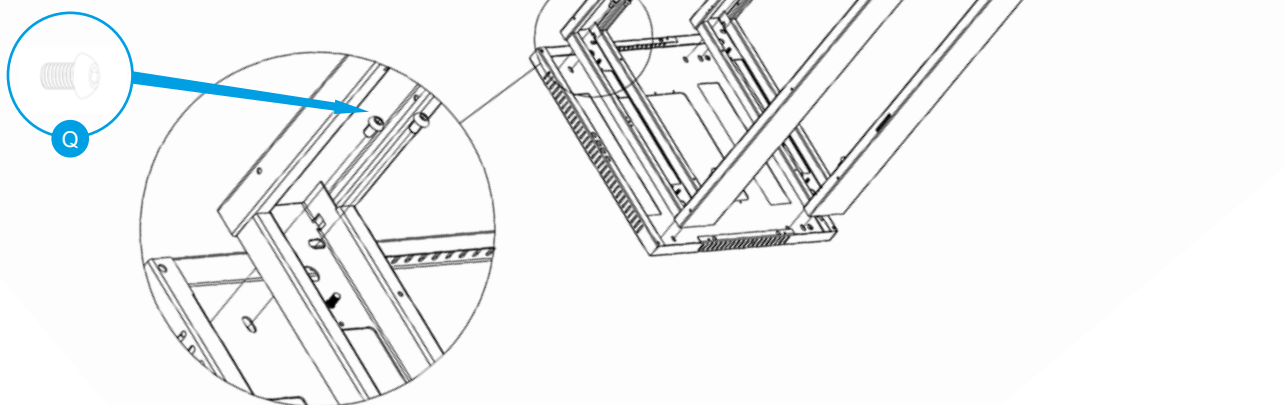

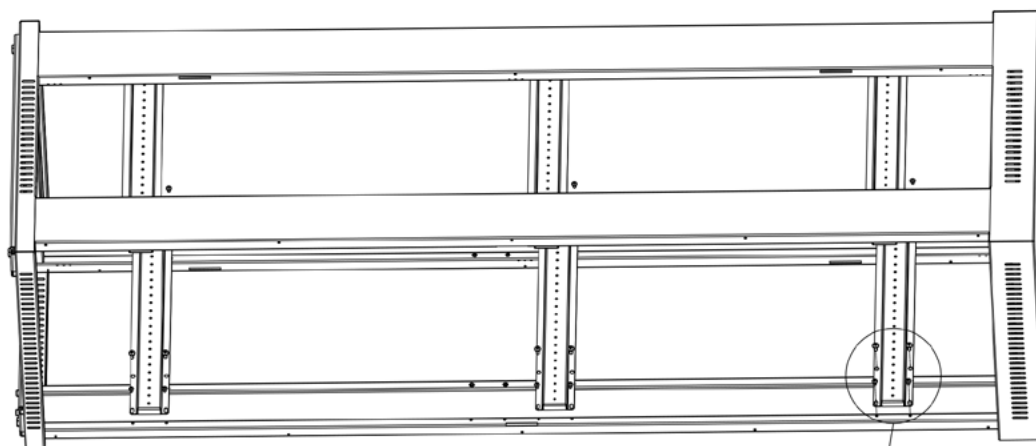

Krok 5. Umiestnite priečník (G) na rám (D) tak, aby ste sa vyhli otvoru určenému pre zámok. Na upevnenie priečníka použite skrutku M5*10 (R2) a samoreznú skrutku M5 (R).

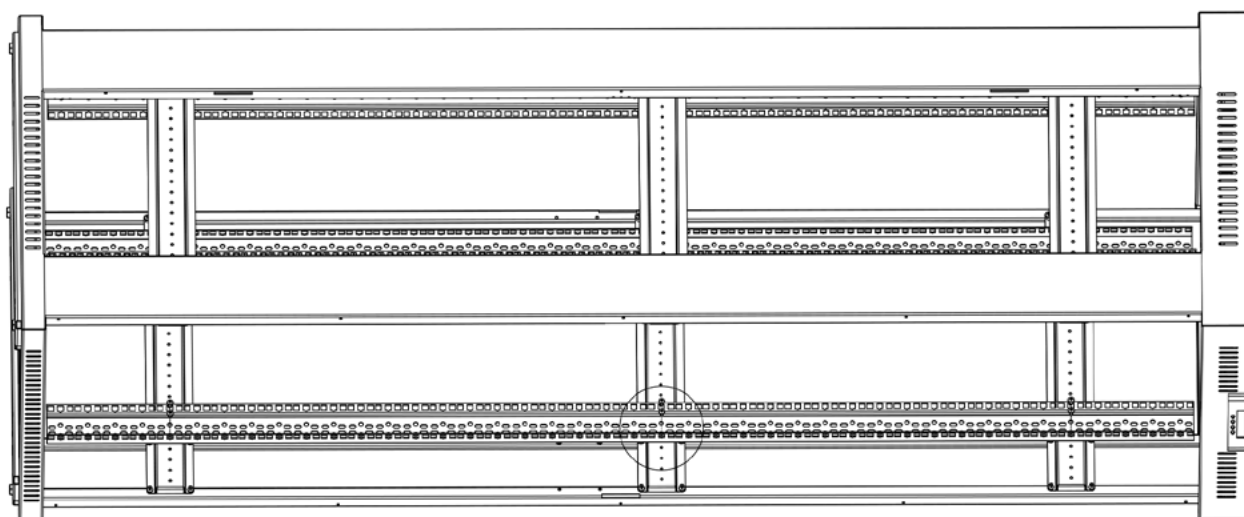
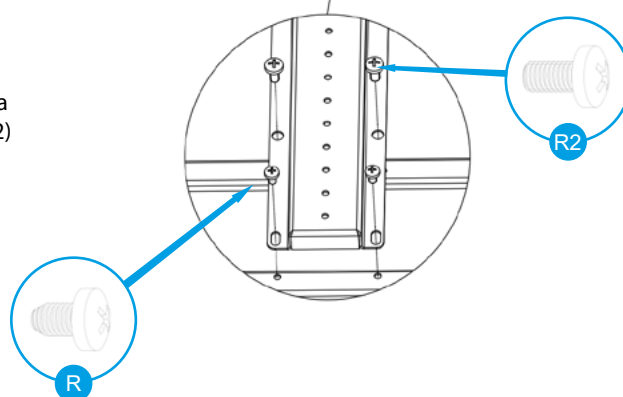

Krok 6. Pripravte samoreznú skrutku M5*10 (R) na upevnenie vertikálnych montážnych líšt (I) k horizontálnym priečnikom (G).

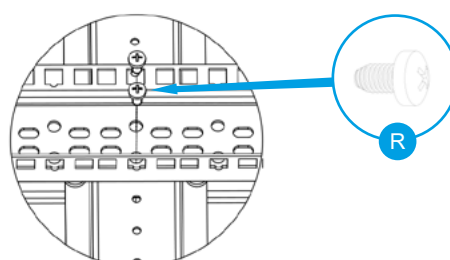

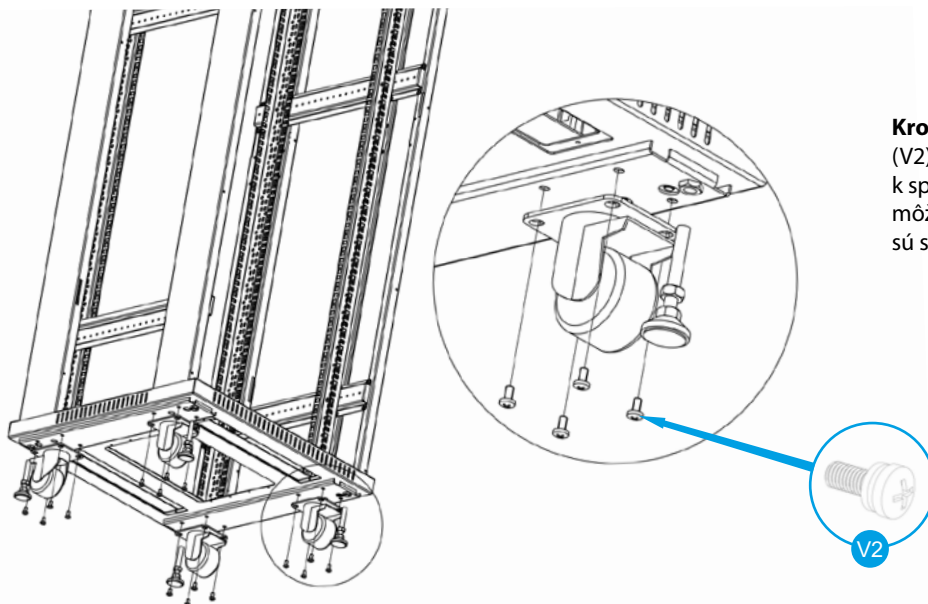

Krok 7. Pripravte skrutky s podložkou (V2) na upevnenie štyroch koliesok (L) k spodnému krytu (F). Namiesto koliesok môžete ku krytu pripievať nožičky (K), ktoré sú súčasťou súpravy.

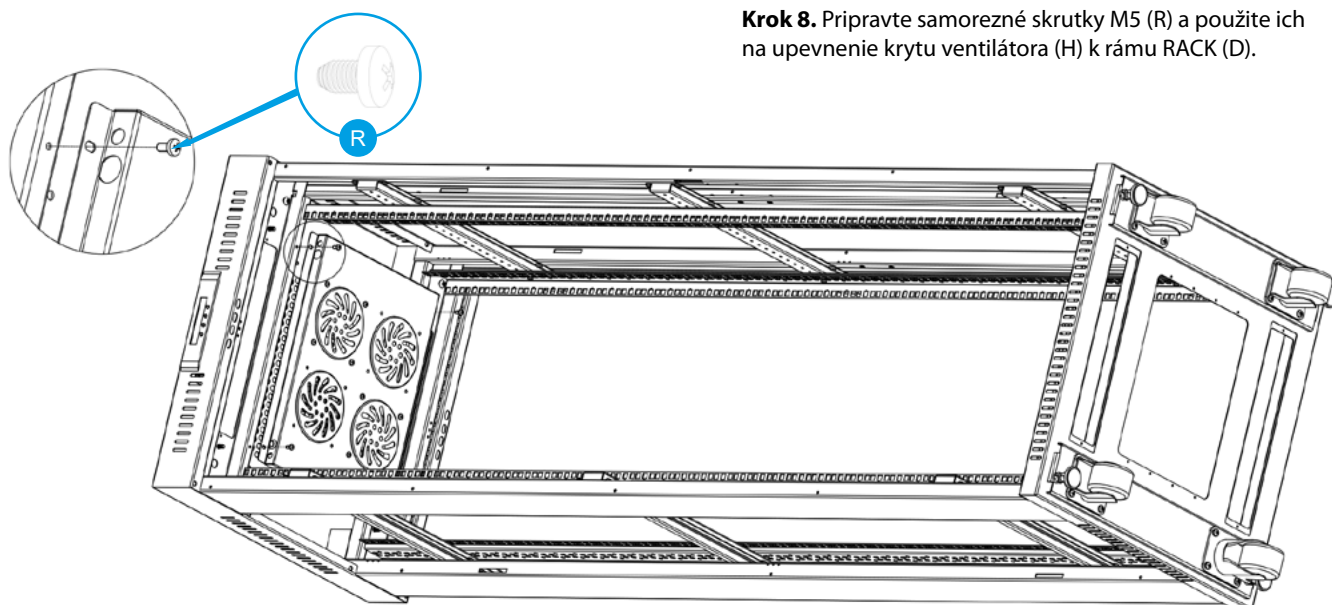

Krok 8. Pripravte samorezné skrutky M5 (R) a použite ich na upevnenie krytu ventilátora (H) k rámu RACK (D).

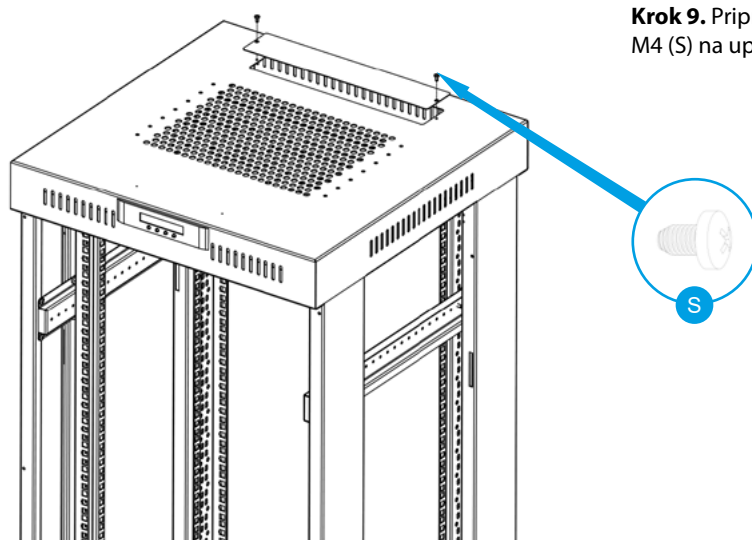

Krok 9. Pripravte a použite samoreznú skrutku M4 (S) na upevnenie krytky horného panelu (J).

Krok 10. Pripravte a použite samorezné skrutky M4 (S) na upevnenie dorazov dverí (item M), 12U~27U (8), 32U~47U (12).

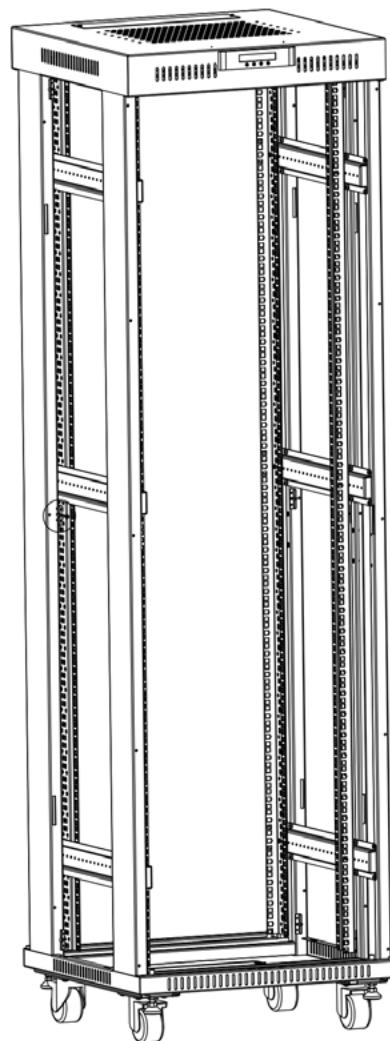

Krok 11. Pripravte a umiestnite dištančné prvky dverí (W) pre predné dvere a zadný panel (A a B) na správne miesta. Bočné panely (C) namontujte až úplne na konci.

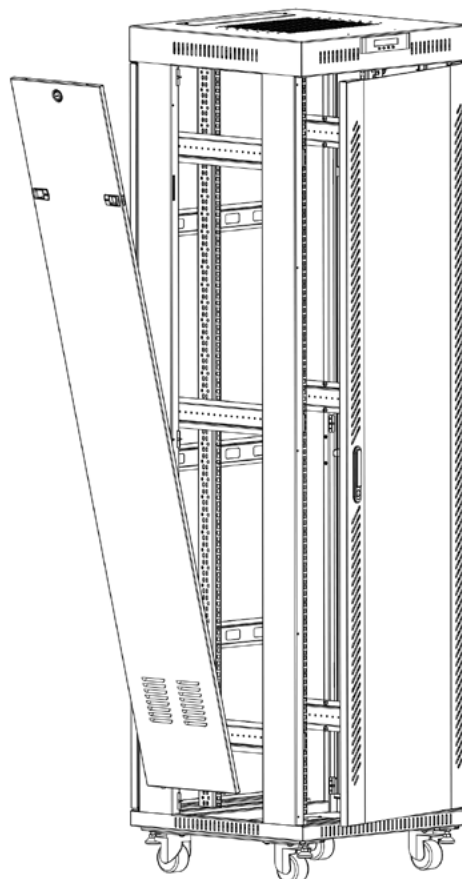
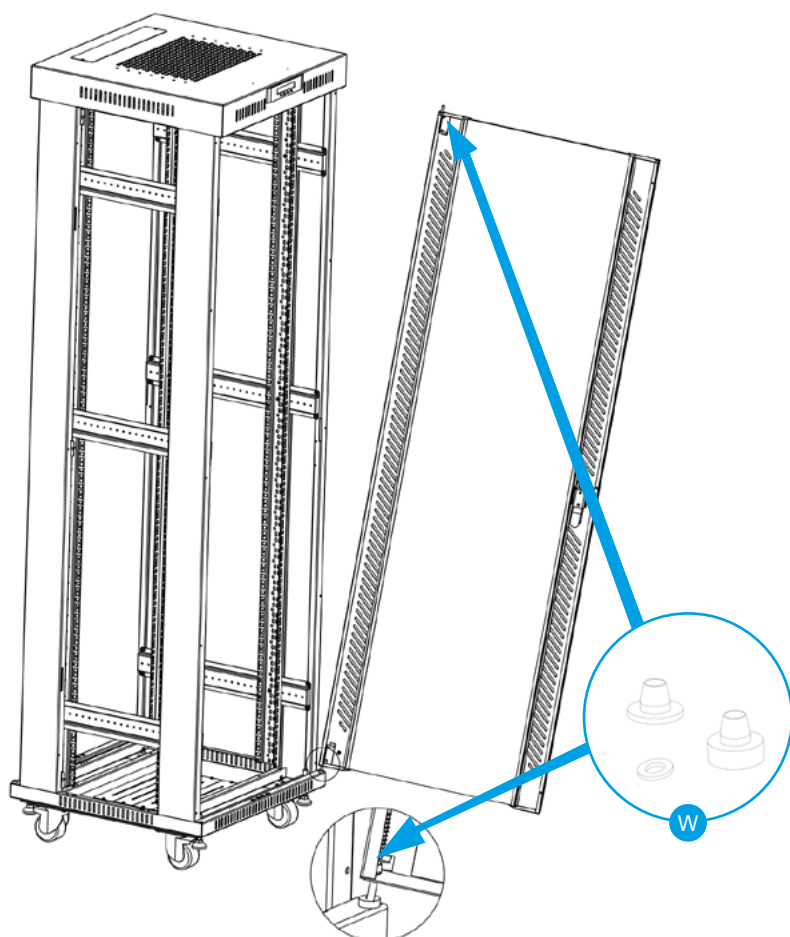







1. Asamblare





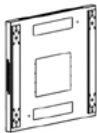
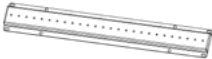
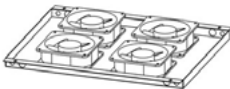

Asigurați-vă că urmați cu strictețe instrucțiunile din acest manual.







1.1 Pregătiri

Pregătiți suficient spațiu liber pe suprafața pe care va avea loc montajul. Scoateți cu grijă toate elementele din cutia de transport. Instrucțiunile suplimentare de montaj se vor baza pe diagrama furnizată

1.1.1. Tabelul componentelor

Elemente ale dulapului		
Nr. articol	Desen	Cantitate furnizată
A		1
B		1
C		2
D		2
E		1
F		1
G		15U~27U 4 32U~47U 6
H		1
I		4
J		3 4

K		4
L		4
M		15U~27U 8 32U~47U 12
N		1
O		3
W		4

Șuruburi			
Nr. articol	Desen	Cantitate furnizată	
Q		17	
R		15U~27U	38
		32U~47U	54
S		15U~27U	24
		32U~47U	28
R2		15U~27U	18
		32U~47U	26
V		20	
V2		17	

2. Etape de instalare

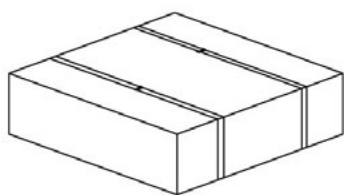

PARTEA SUPERIOARĂ ȘI
INFERIOARĂ - PACHET 1/3

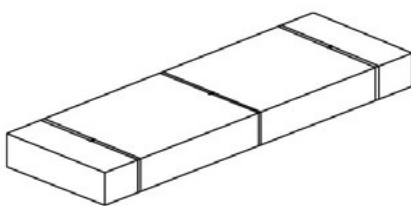

UȘA FRONTALĂ, UȘA DIN SPATE
ȘI PANOURILE LATERALE -
PACHET 2/3

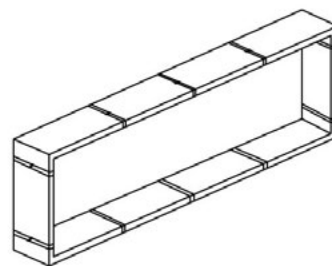

CADRU - PACHET 3/3

Pasul 1. Îndepărtați încuietoarea ușii frontale (N), încuietorile panourilor laterale și încuietoarea panoului din spate (O); componentele se află în pachetul 1/3. Apoi scoateți ușa frontală din sticlă (A), panoul din spate (B) și panourile laterale (C) din pachetul 2/3. În această etapă începem prin montarea încuietorilor pe componentele menționate mai sus.

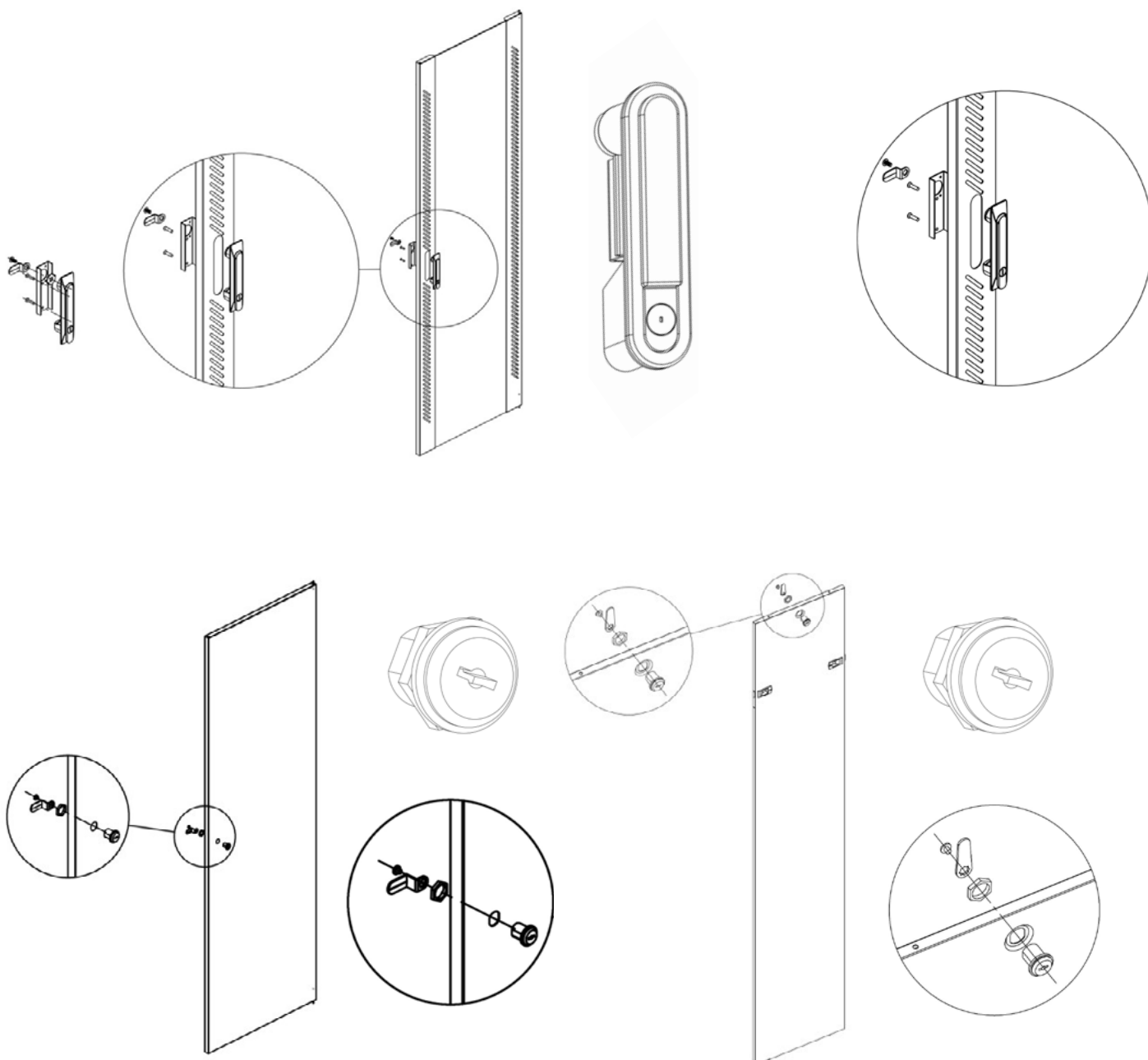

Pasul 2. Despachetați părțile cadrului (D) din pachetul 3/3. Apoi așezați cadrele paralel unul cu celălalt, cu orificiile pătrate orientate spre interior. Puteți identifica partea inferioară a cadrului după elementele de împănțare.

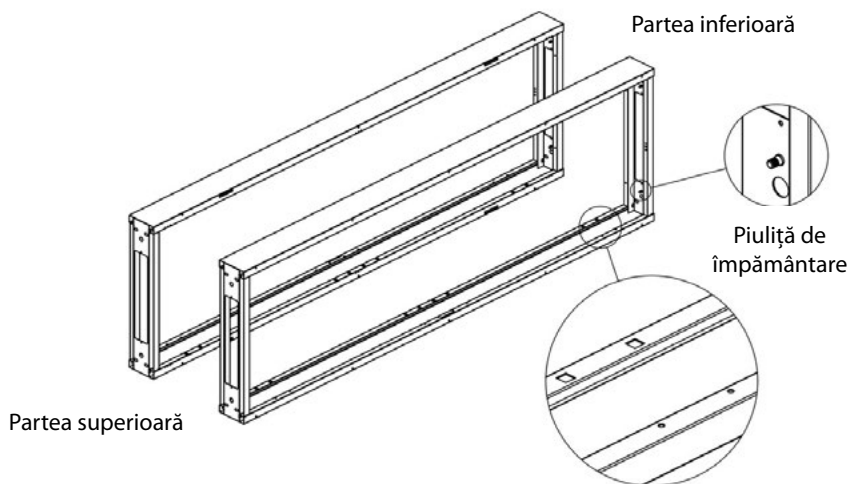

Pas 3. Montați capacul superior (E) pe părțile superioare ale cadrului (D), apoi uniți-le cu un șurub imbus M8 (Q).

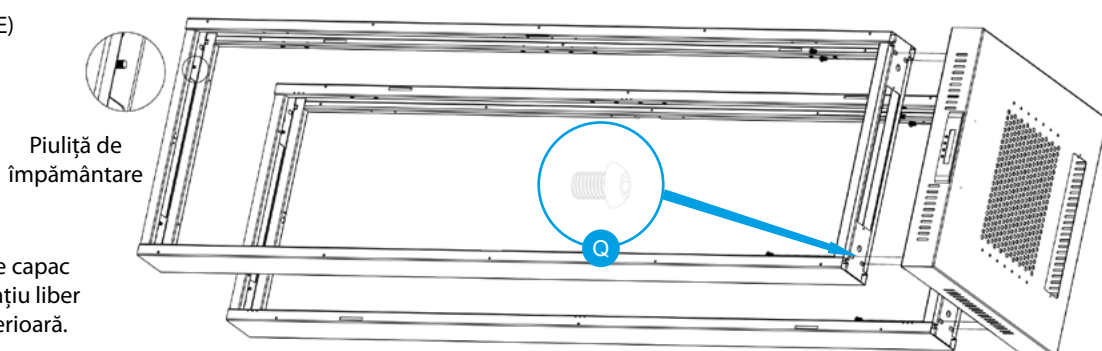

Notă: Cadrele trebuie montate pe capac astfel încât să nu existe niciun spațiu liber între cadru și capac pe partea interioară.

Pas 4. Așezați capacul inferior (F) pe partea inferioară a cadrului (D) și utilizați șurubul imbus M8 (Q) pentru a le conecta.

Notă: Cadrele trebuie montate pe capac astfel încât să nu existe niciun spațiu liber între cadru și capac pe partea interioară.

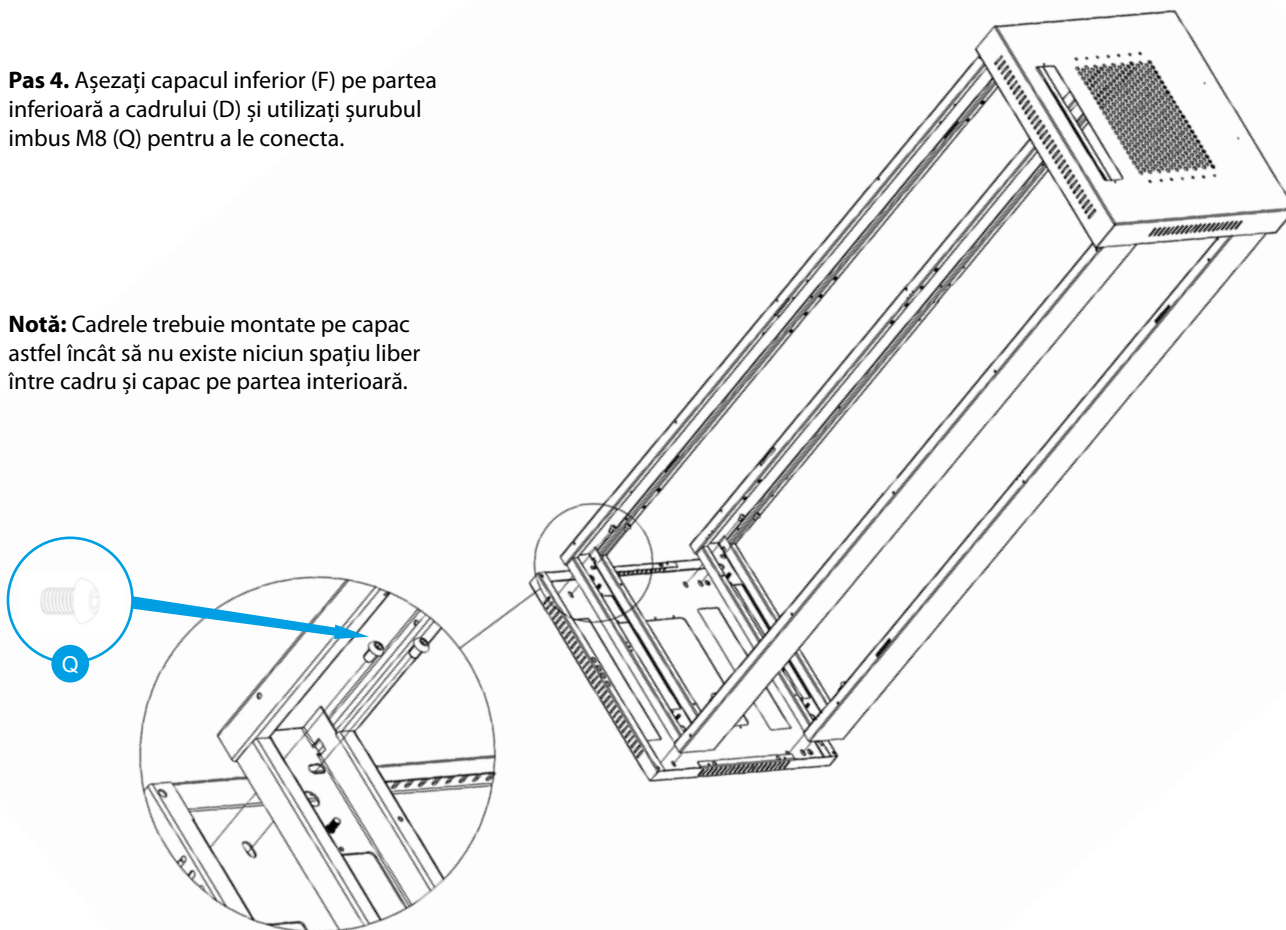

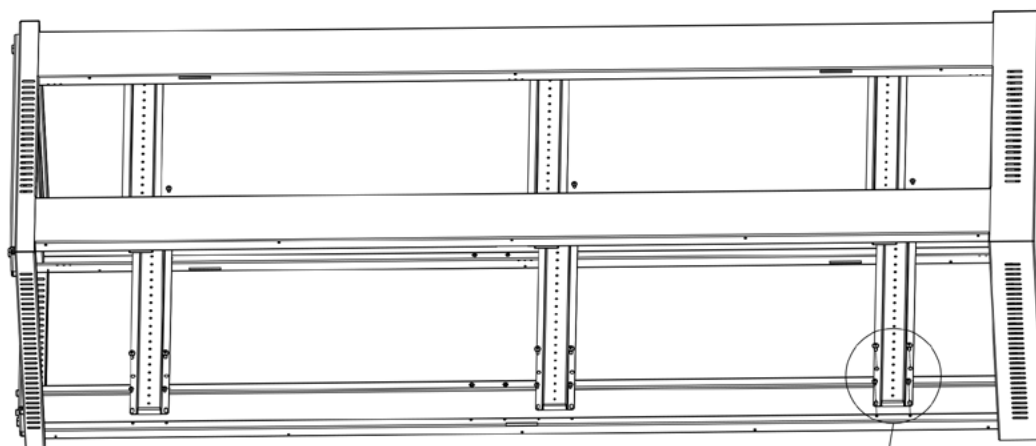

Pas 5. Așezați bara transversală (G) pe cadru (D), evitând orificiul destinat încălzirii. Folosiți un șurub M5*10 (R2) și un șurub autofiletant M5 (R) pentru a fixa bara transversală.

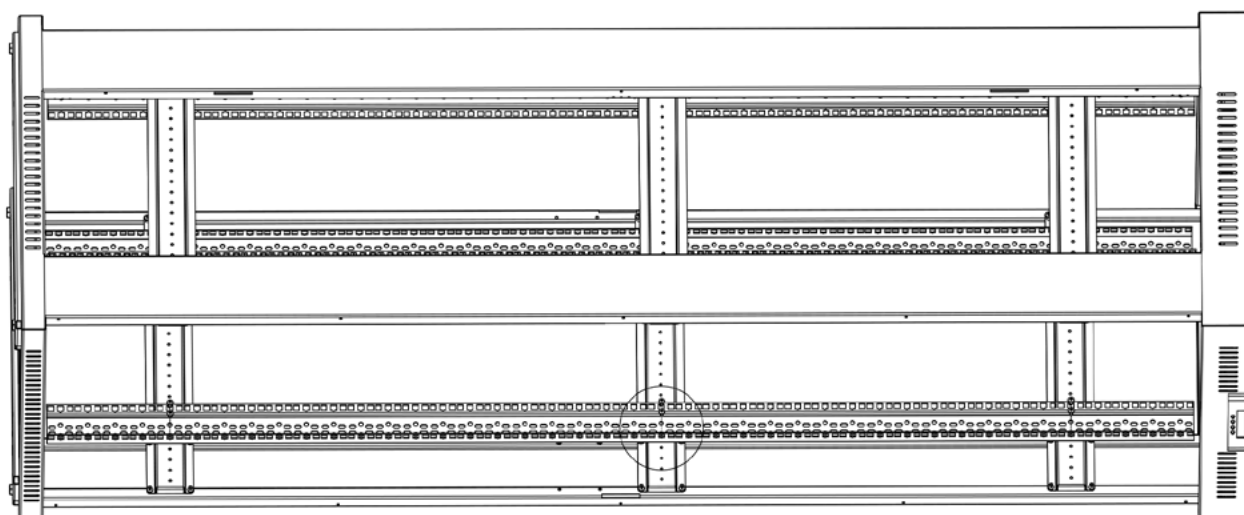
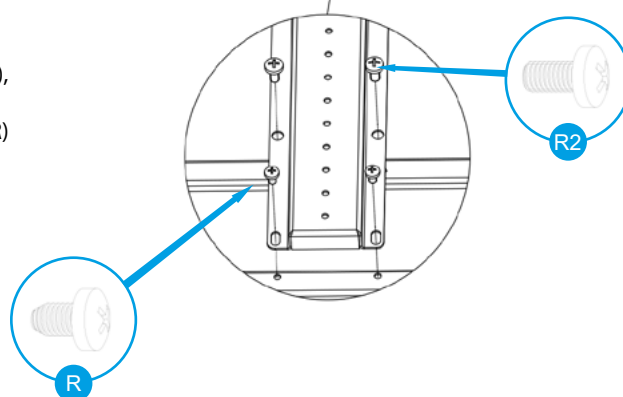

Pas 6. Pregătiți un șurub autofiletant M5*10 (R) pentru a fixa șinele verticale de montaj (I) pe traversele orizontale (G).

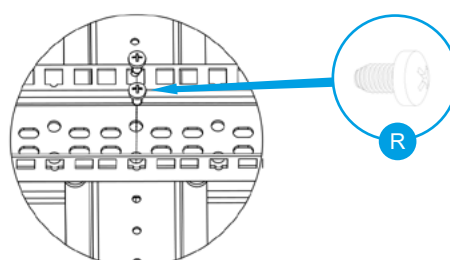

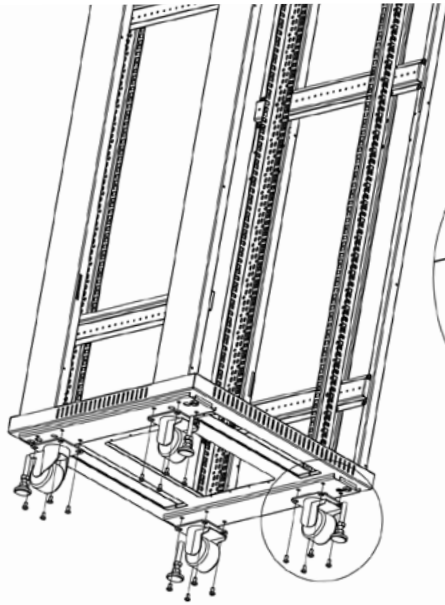

Pas 7. Pregătiți șuruburi cu șaiță (V2) pentru a fixa cele patru roți (L) pe capacul inferior (F). Alternativ, în locul roților, puteți fixa pe capac picioarele (K) incluse în kit.

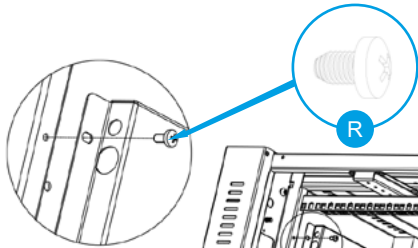
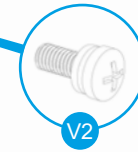
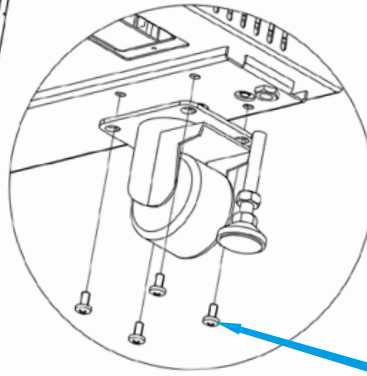

Pas 8. Pregătiți șuruburi autofiletante M5 (R) și folosiți-le pentru a fixa capacul ventilatorului (H) pe cadrul RACK (D).

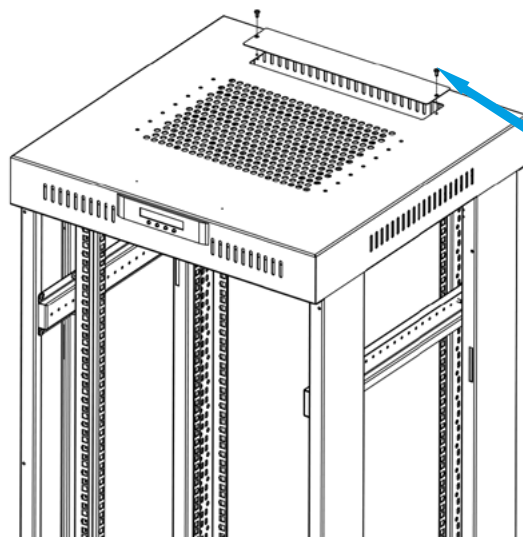
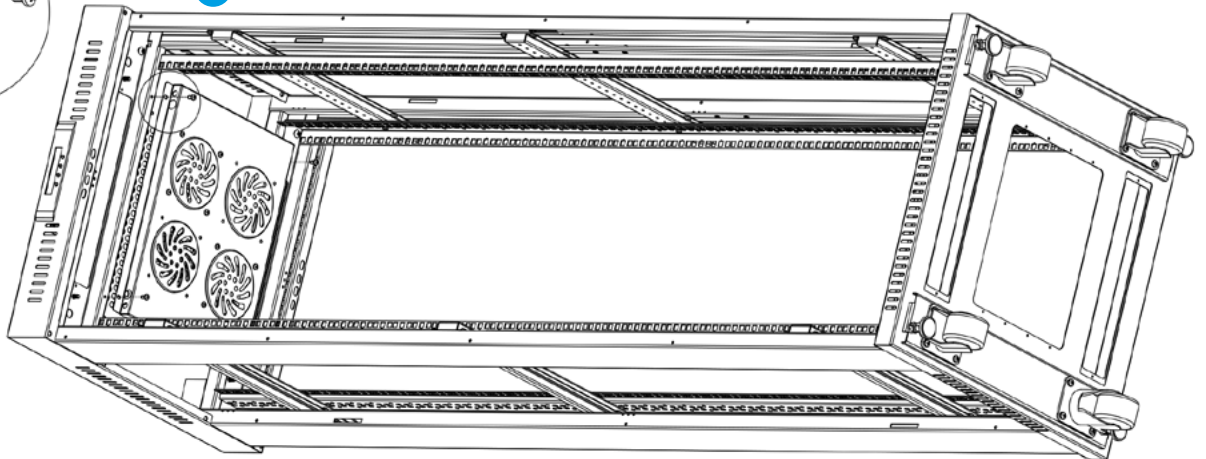

Pas 9. Pregătiți și utilizați un șurub autofiletant M4 (S) pentru a fixa capacul panoului superior (J).

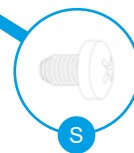

Pas 10. Pregătiți și utilizați șuruburi autofiletante M4 (S) pentru a fixa opritoarele ușii (M), 12U~27U (8), 32U~47U (12).

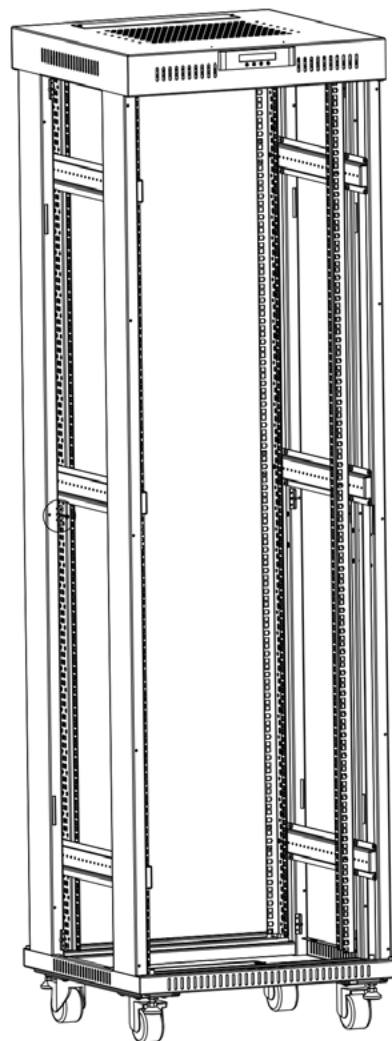

Pas 11. Pregătiți și poziționați distanțierele pentru uși (W) pentru ușa frontală și panoul din spate (items A și B) în locurile corespunzătoare. Montați panourile laterale (C) la final.

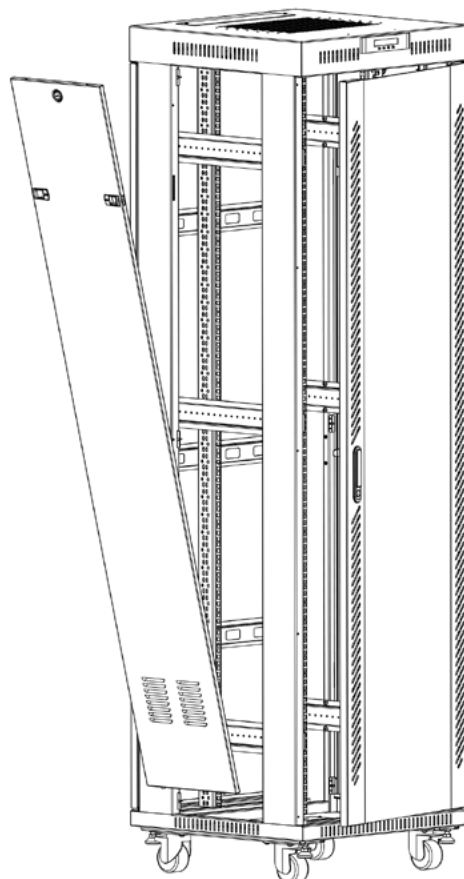
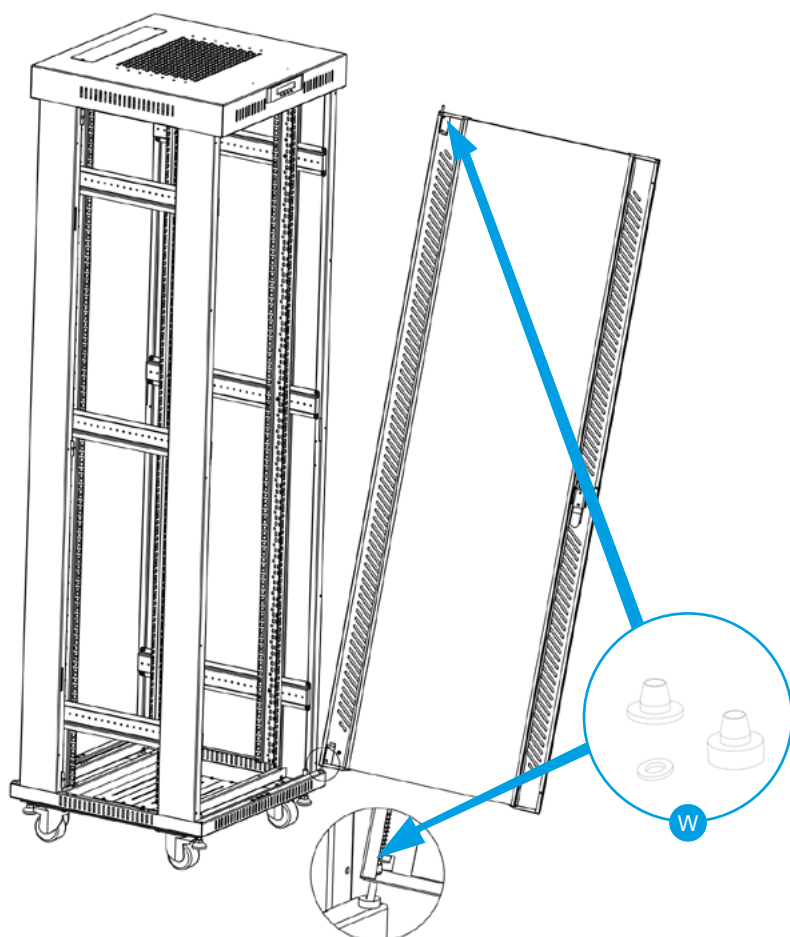







1. Монтаж





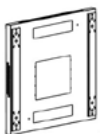
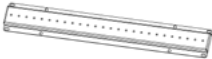
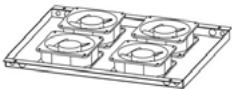

Не забравяйте стриктно да следвате инструкциите в това ръководство.







1.1 Подготовка

Подгответе достатъчно свободно място върху повърхността, на която ще се извърши монтажът. Внимателно извадете всички елементи от транспортната кутия. Следващите инструкции за монтаж ще се основават на предоставената схема

1.1.1. Таблица на компонентите

Елементи на шкафа		
№ на елемента	Чертеж	Доставено количество
A		1
B		1
C		2
D		2
E		1
F		1
G		15U~27U 4 32U~47U 6
H		1
I		4
J		3 4

K		4
L		4
M		15U~27U 8 32U~47U 12
N		1
O		3
W		4

Винтове			
№ на елемента	Чертеж	Доставено количество	
Q		17	
R		15U~27U	38
		32U~47U	54
S		15U~27U	24
		32U~47U	28
R2		15U~27U	18
		32U~47U	26
V		20	
V2		17	

2. Стъпки за монтаж

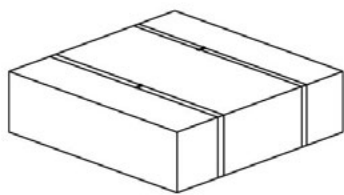

ГОРНА И ДОЛНА ЧАСТ -
ПАКЕТ 1/3

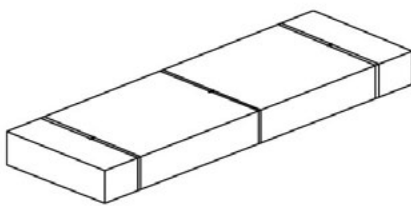

ПРЕДНА, ЗАДНА И СТРАНИЧНИ
ВРАТИ - ПАКЕТ 2/3

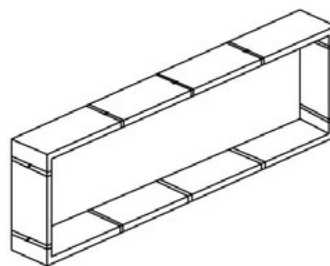

РАМКА - ПАКЕТ 3/3

Стъпка 1. Свалете ключалката на предната врата (N), ключалките на страничните панели и ключалката на задния панел (O); компонентите се намират в пакет 1/3. След това извадете предната стъклена врата (A), задния панел (Елемент В) и страничните панели (С) от пакет 2/3. На този етап започваме с монтирането на ключалките върху горепосочените компоненти.

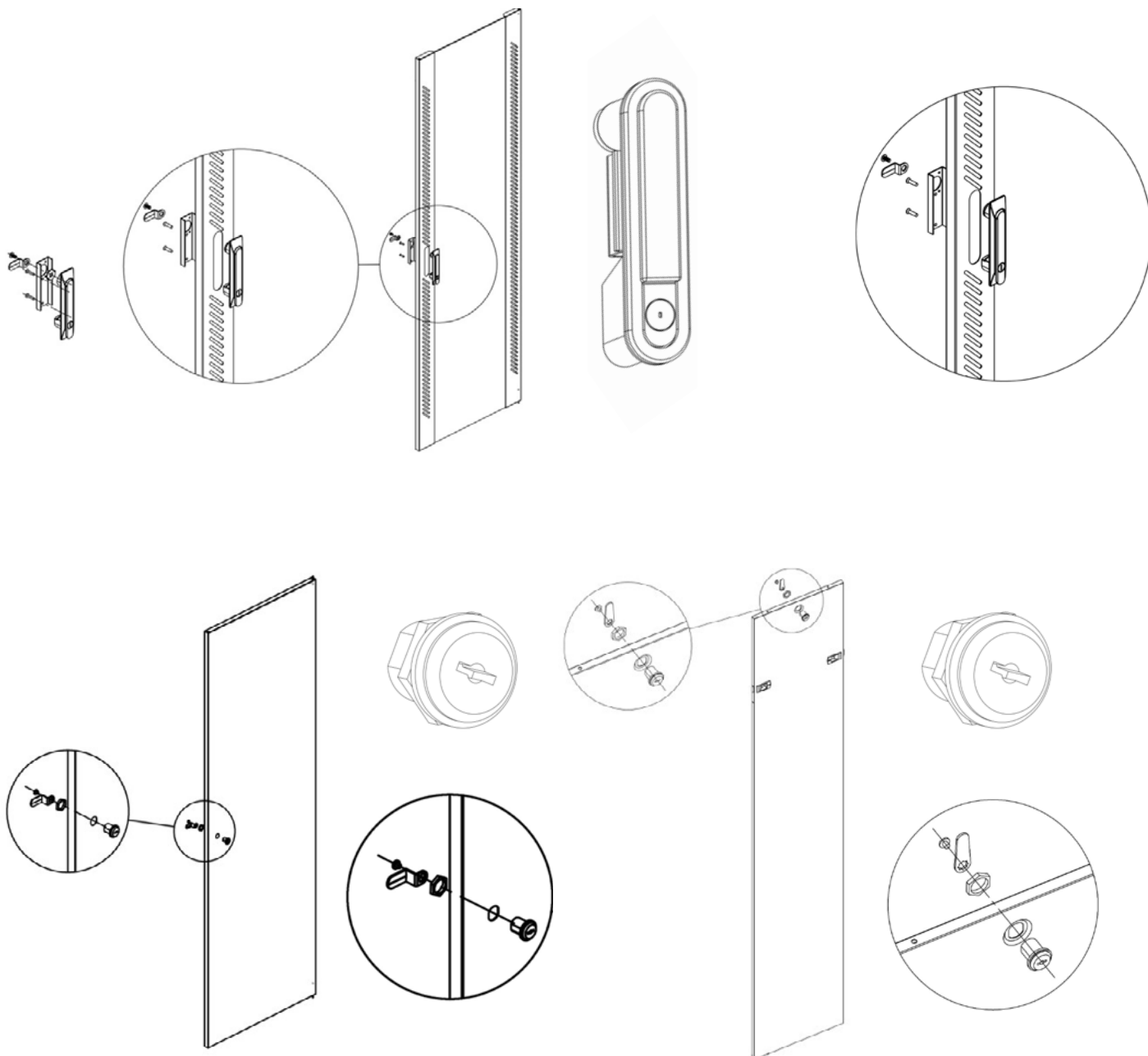

Стъпка 2. Разпакувайте частите на рамката (D) от пакет 3/3. След това подредете рамките успоредно една на друга, като квадратните отвори са насочени навътре. Можете да разпознаете долната част на рамката по заземяващите елементи.

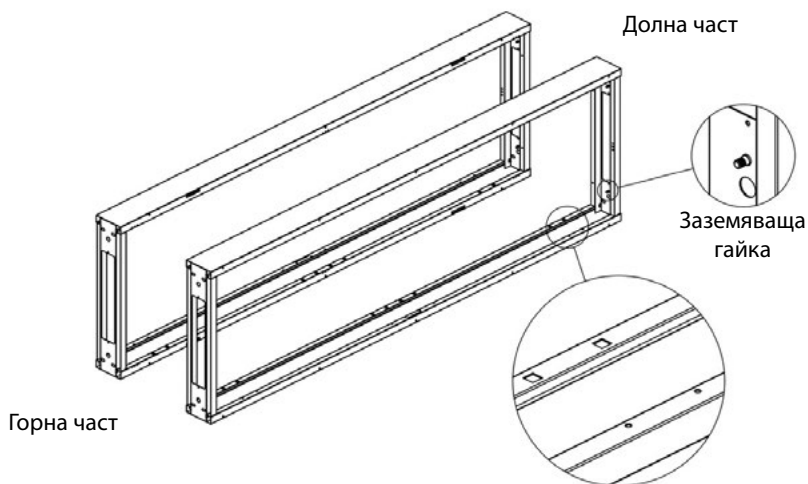

Стъпка 3. Поставете горния капак (E) към горните части на рамката (D), след което ги свържете с M8 винт с вътрешен шестостен (Q).

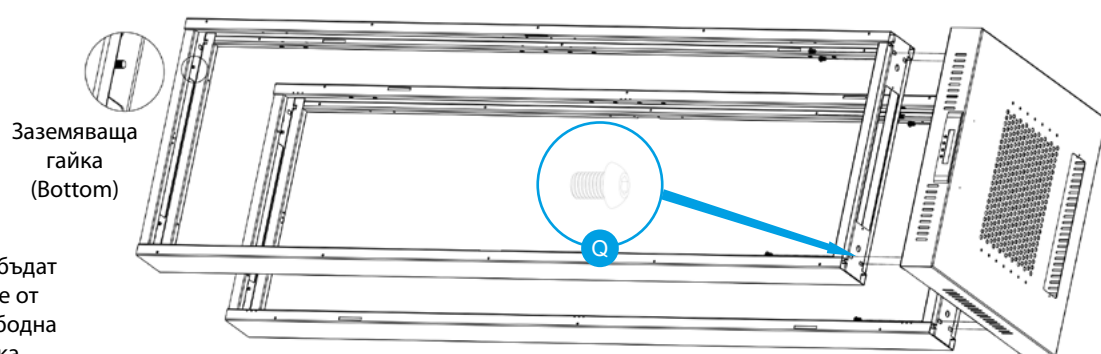

Забележка: Рамките трябва да бъдат монтирани върху капака така, че от вътрешната страна да няма свободна междина между рамката и капака.

Стъпка 4. Поставете долния капак (F) върху долната част на рамката (D) и използвайте M8 винта с вътрешен шестостен (Q), за да ги свържете.

Забележка: Рамките трябва да бъдат монтирани върху капака така, че от вътрешната страна да няма свободна междина между рамката и капака.

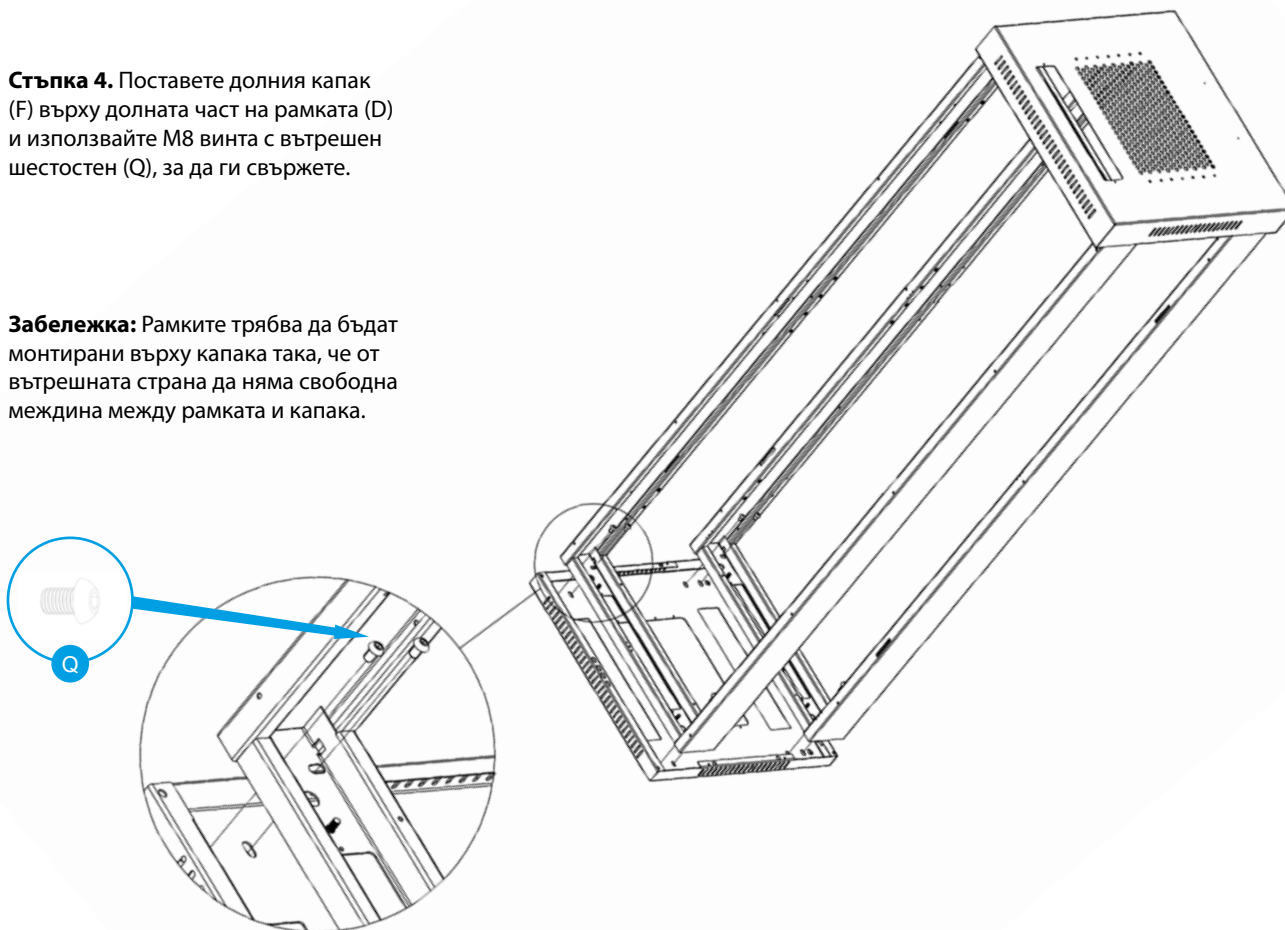

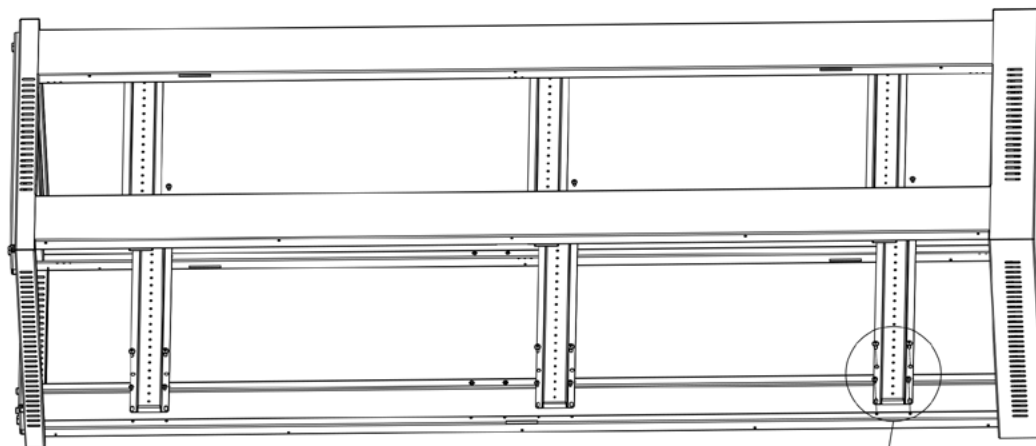

Стъпка 5. Поставете напречната греда (G) върху рамката (D), като избягвате отвора, предназначен за ключалката. Използвайте винт M5*10 (R2) и самонарезен винт M5 (Елемент R), за да закрепите напречната греда.

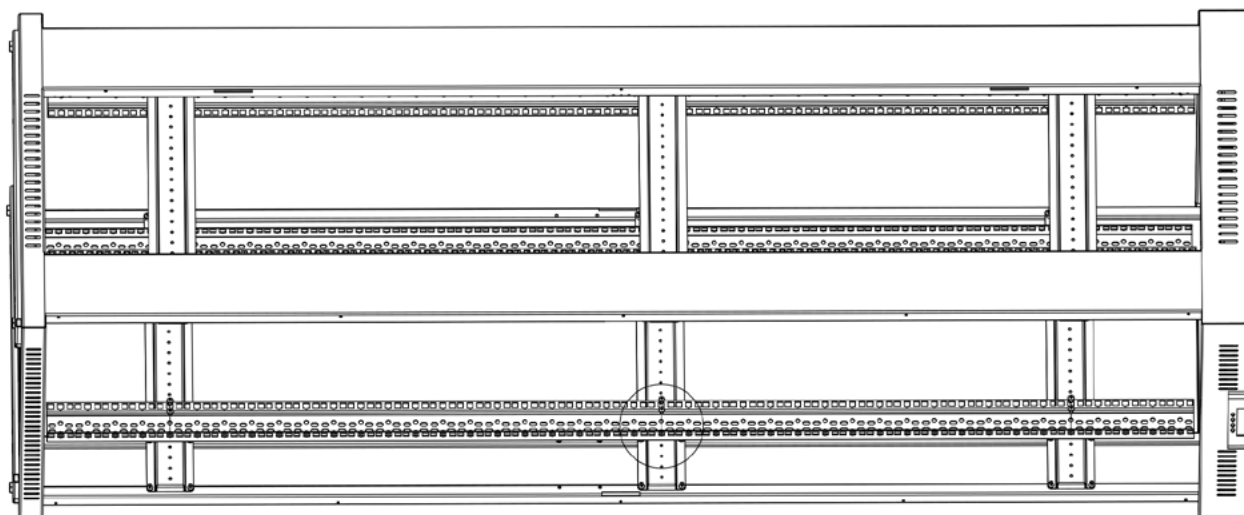
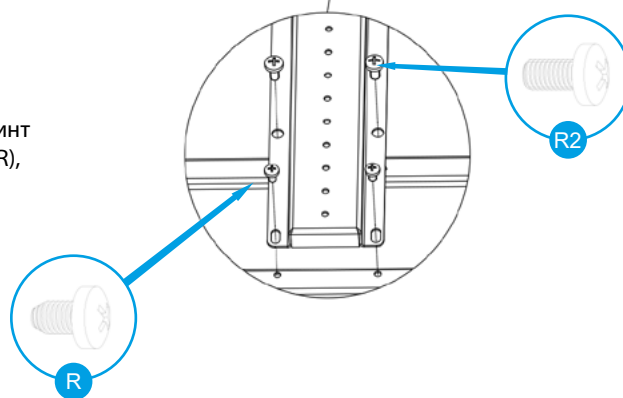

Стъпка 6. Подгответе самонарезен винт M5*10 (R), за да закрепите вертикалните монтажни релси (I) към хоризонталните напречни греди (G).

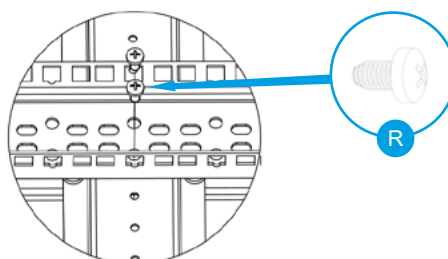

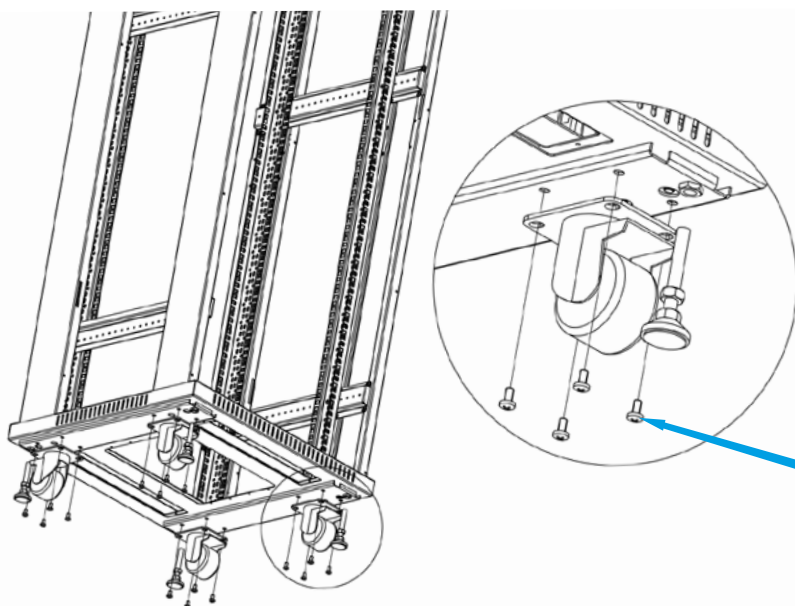

Стъпка 7. Подгответе винтове с шайба (V2), за да закрепите четирите колелца (L) към долния капак (F). Като алтернатива, вместо колелцата, можете да закрепите към капака крачетата (K), които са включени в комплекта.

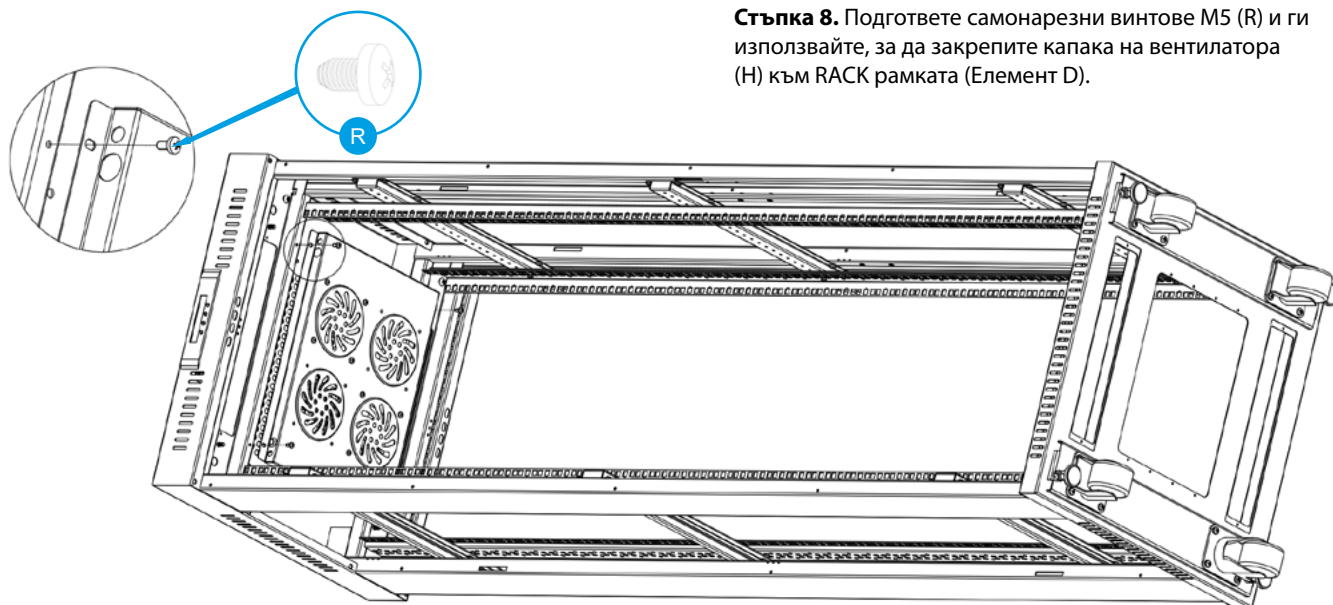

Стъпка 8. Подгответе самонарезни винтове M5 (R) и ги използвайте, за да закрепите капака на вентилатора (H) към RACK рамката (Елемент D).

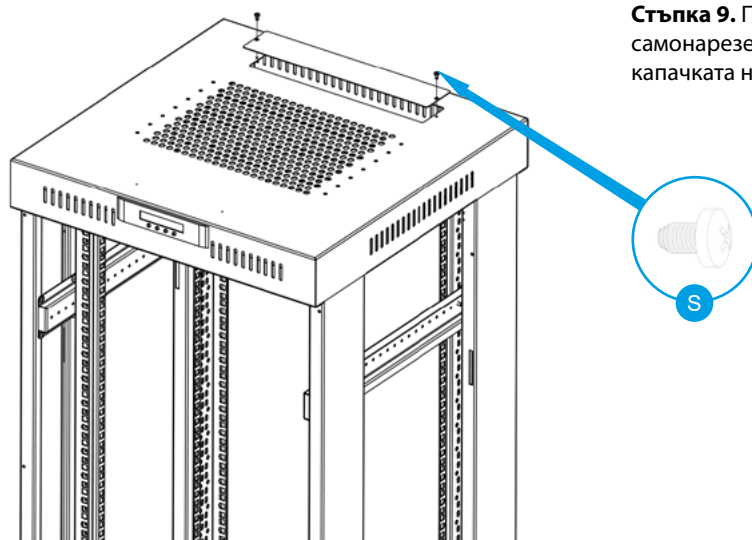

Стъпка 9. Подгответе и използвайте самонарезен винт M4 (S), за да закрепите капачката на горния панел (J).

Стъпка 10. Подгответе и използвайте самонарезни винтове М4 (S), за да закрепите ограничителите на вратата (M), 12U~27U (8), 32U~47U (12).

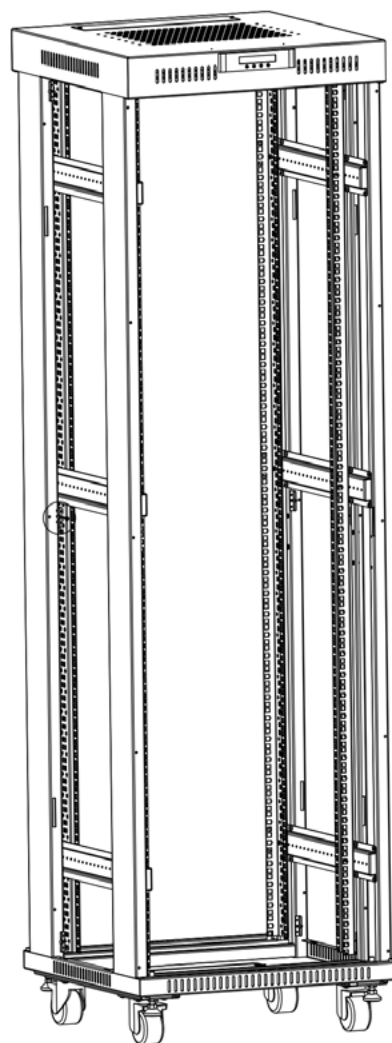

Стъпка 11. Подгответе и поставете дистанционерите за вратите (W) за предната врата и задния панел (А и В) на съответните места. Монтирайте страничните панели (С) най-накрая.

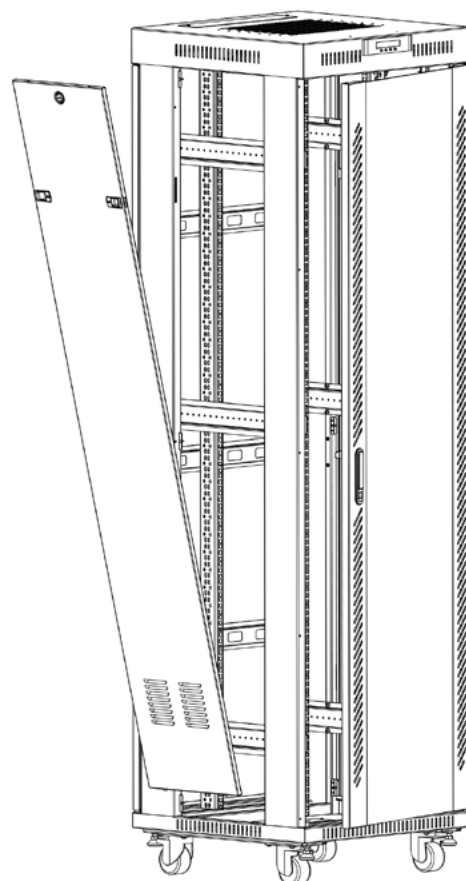
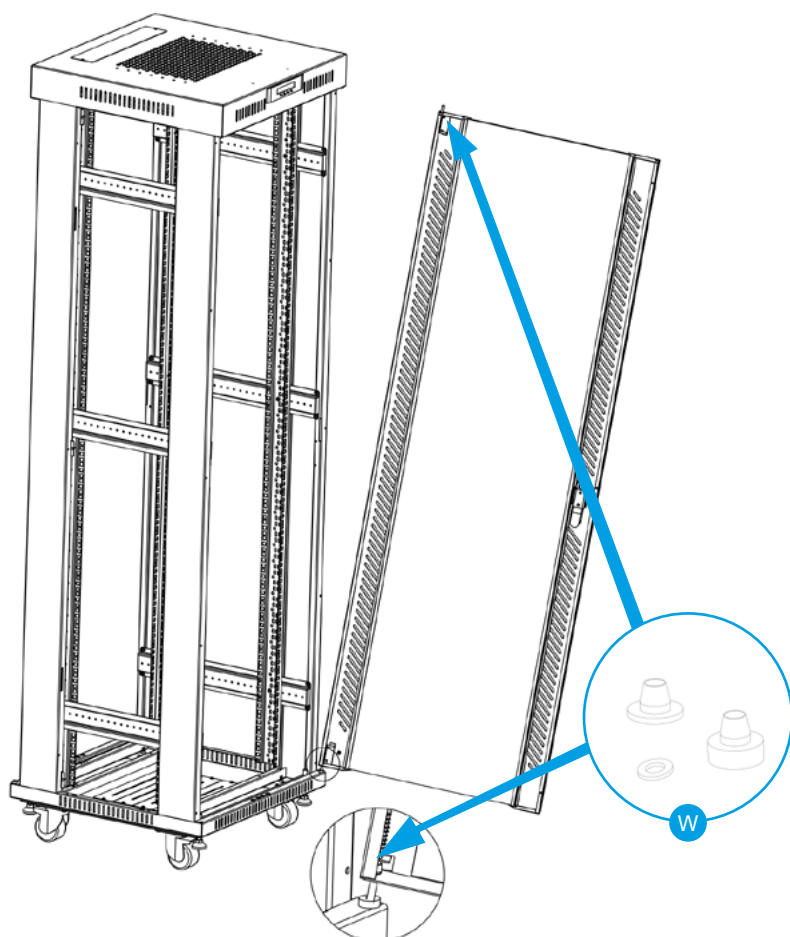







1. Összeszerelés





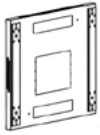
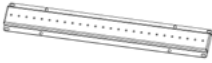
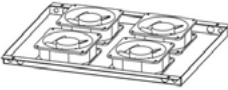

Feltétlenül tartsa be ennek a kézikönyvnek az utasításait.







1.1 Előkészületek

Készítsen elő elegendő szabad helyet azon a felületen, ahol az összeszerelés történik. Óvatosan vegye ki az összes elemet a szállítódobozból. A további összeszerelési utasítások a mellékelt ábrán alapulnak

1.1.1. Alkatrésztáblázat

A szekrény elemei		
Tételszám	Rajz	Szállított mennyiség
A		1
B		1
C		2
D		2
E		1
F		1
G		15U~27U 4 32U~47U 6
H		1
I		4
J		3 4

K		4
L		4
M		15U~27U 8 32U~47U 12
N		1
O		3
W		4

Csavarok			
Tételszám	Rajz	Szállított mennyiség	
Q		17	
R		15U~27U	38
		32U~47U	54
S		15U~27U	24
		32U~47U	28
R2		15U~27U	18
		32U~47U	26
V		20	
V2		17	

2. Szerelési lépések

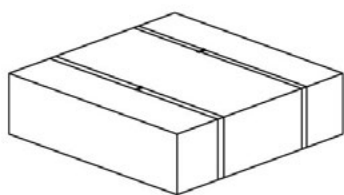

FELSŐ ÉS ALSÓ RÉSZ - 1/3
CSOMAG

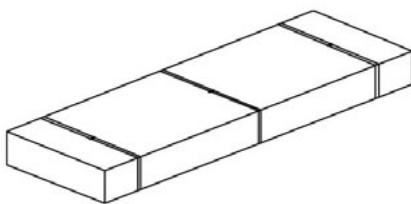

ELSŐ, HÁTSÓ ÉS OLDALSÓ
AJTÓK - 2/3 CSOMAG

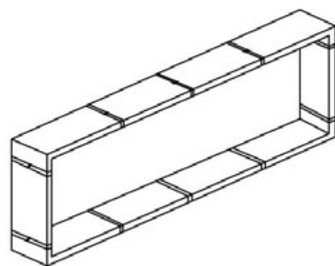

VÁZ - 3/3 CSOMAG

1. lépés Távolítsa el az első ajtó zárját (N), az oldalpanelek zárjait és a hátsó panel zárját (O); az alkatrészek az 1/3 csomagban találhatóak. Ezután vegye ki az elülső üvegajtót (A), a hátsó panelt (B) és az oldalpaneleket (C) a 2/3 csomagból. Ebben a szakaszban a zárok felszerelésével kezdünk a fenti elemekre.

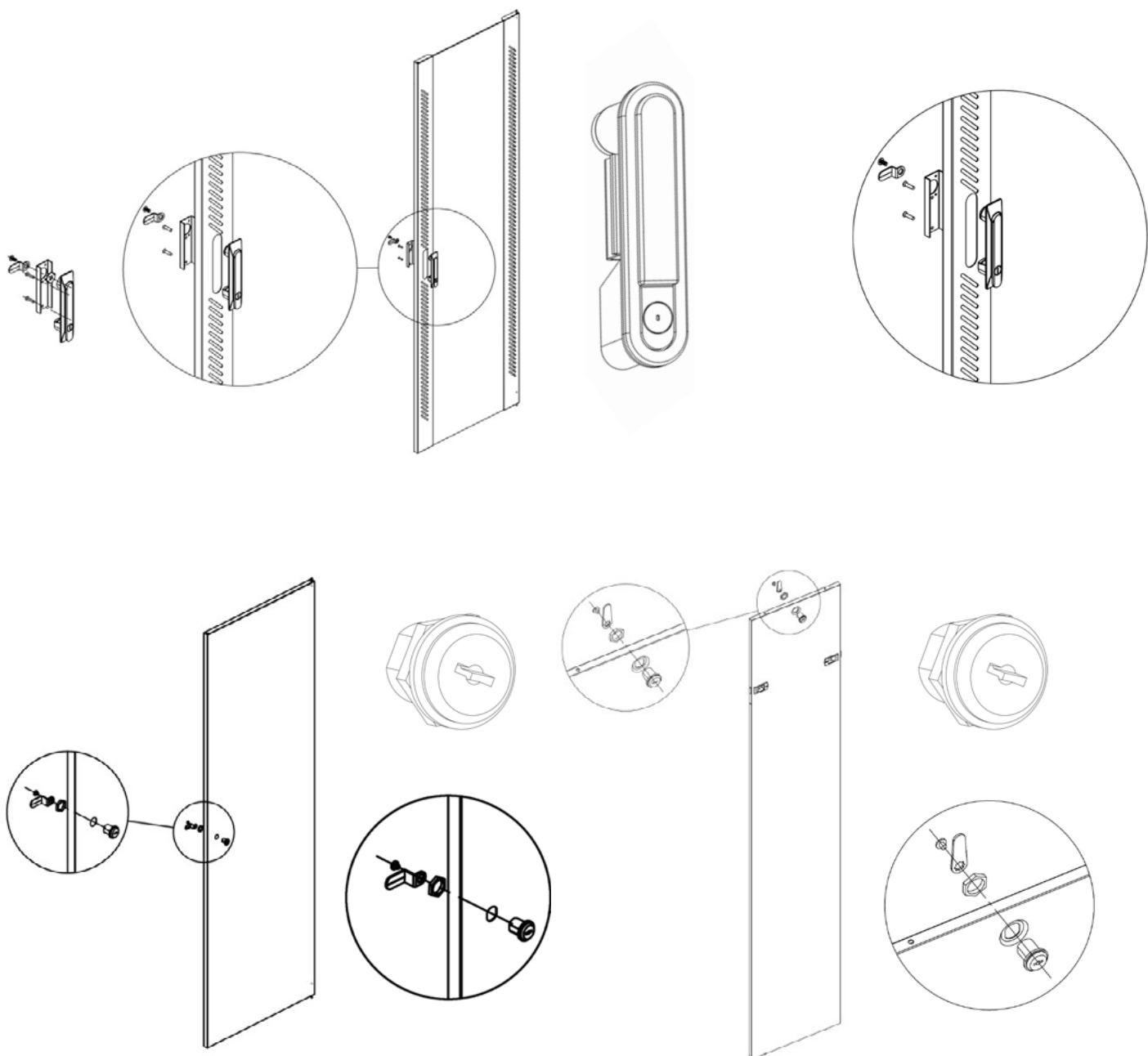

2. lépés. Csomagolja ki a váz részeit (D) a 3/3 csomagból. Ezután rendezze a vázakat egymással párhuzamosan, a négyzet alakú nyílásokkal befelé. A váz alsó része a földelő elemekről ismerhető fel.

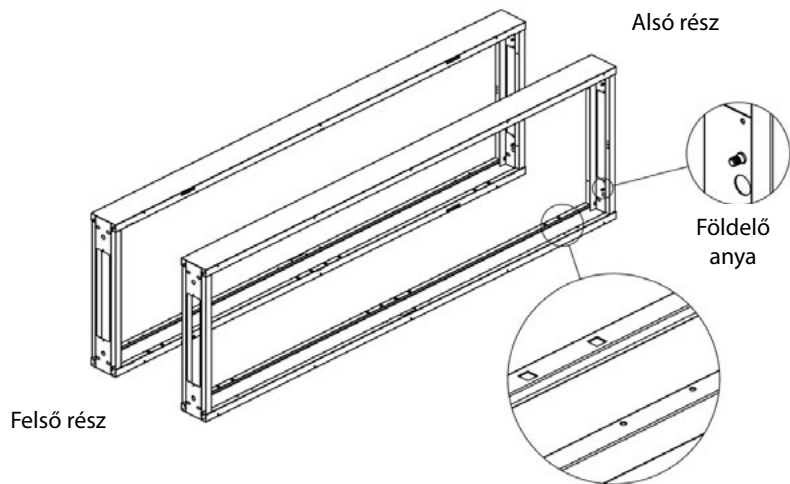

Lépés 3. Illessze a felső fedelet (E) a váz felső részeihez (D), majd csatlakoztassa őket egy M8 imbuszcavarral (Q).

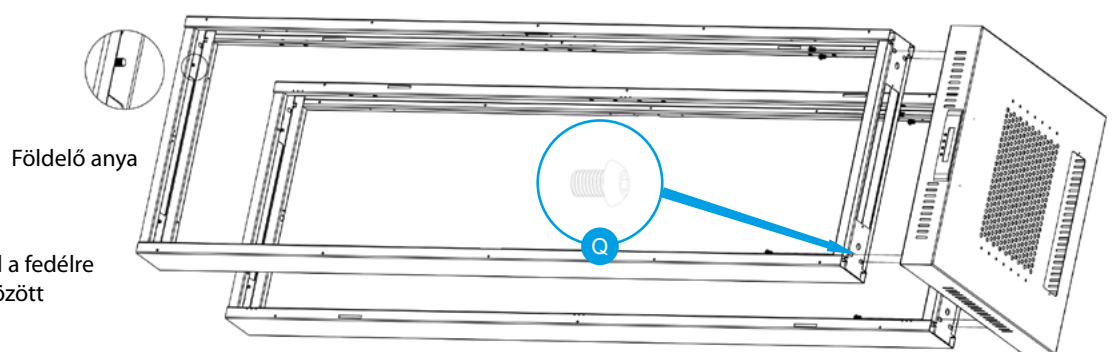

Megjegyzés: A kereteket úgy kell a fedélre szerelni, hogy a keret és a fedél között belülről ne maradjon szabad rés.

Lépés 4. Helyezze az alsó fedelet (F) a váz alsó részére (D), és használja az M8 imbuszcavart (Q) az összekapcsolásukhoz.

Megjegyzés: A kereteket úgy kell a fedélre szerelni, hogy a keret és a fedél között belülről ne maradjon szabad rés.

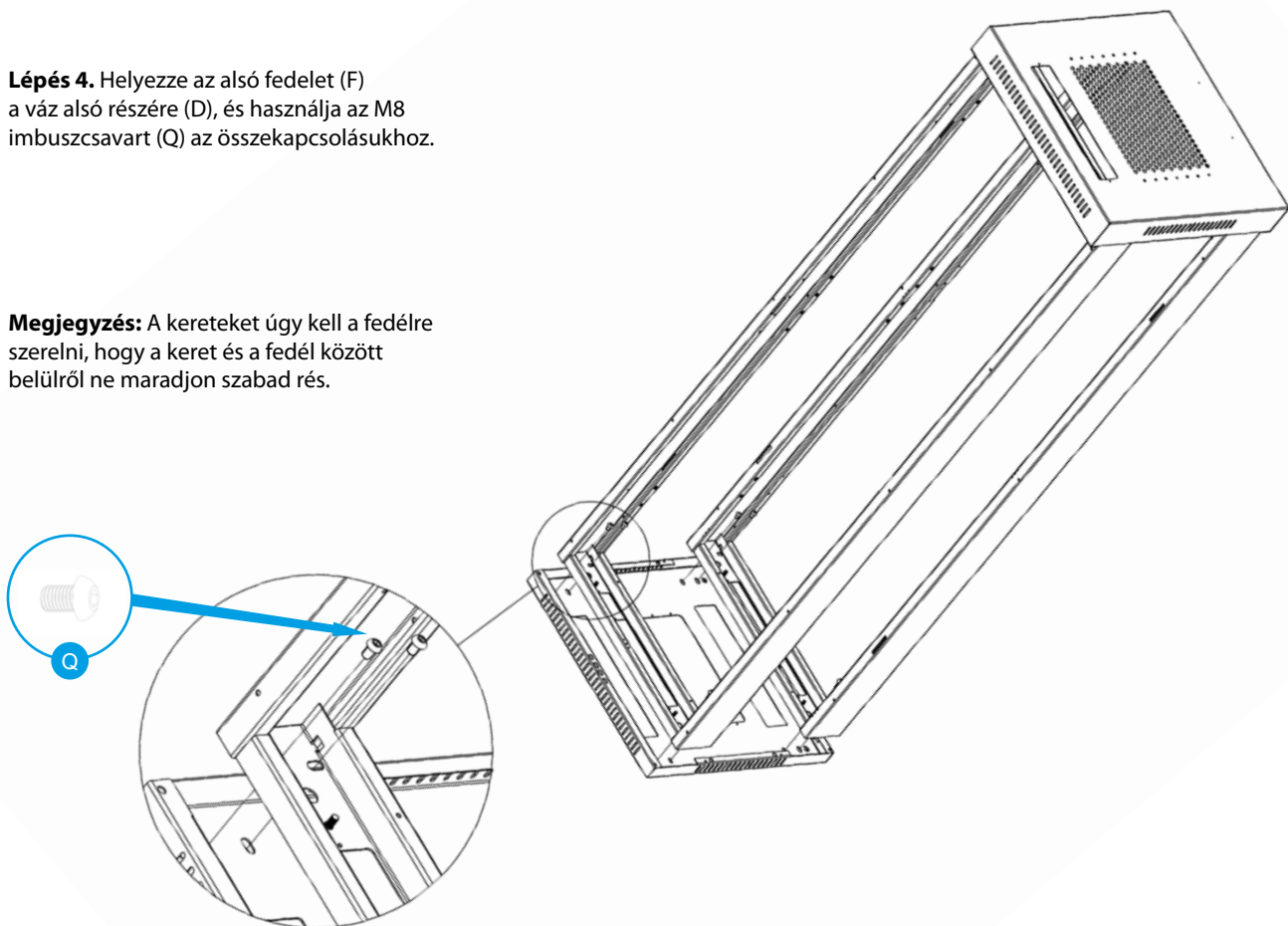

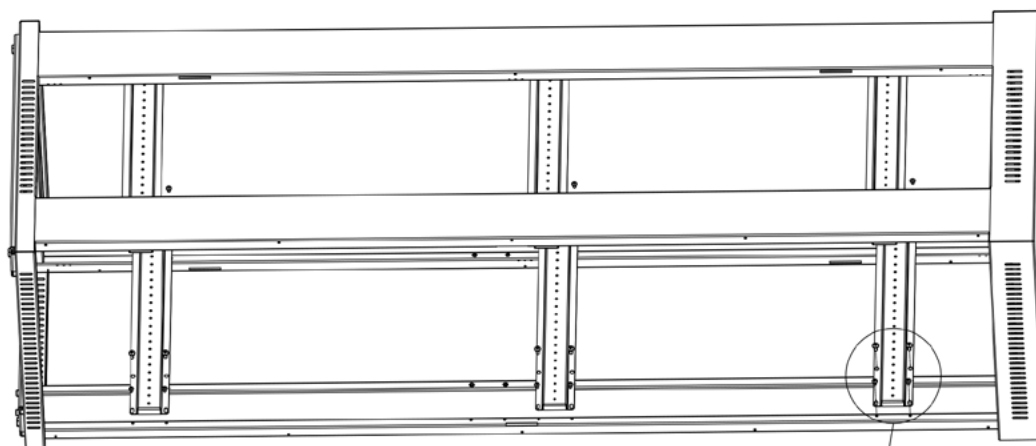

Lépés 5. Helyezze a keresztmervítőt (G) a vázra (D), kerülve a zár számára kialakított furatot. A keresztmervítő rögzítéséhez használjon egy M5*10 csavart (R2) és egy M5 önmetsző csavart (R).

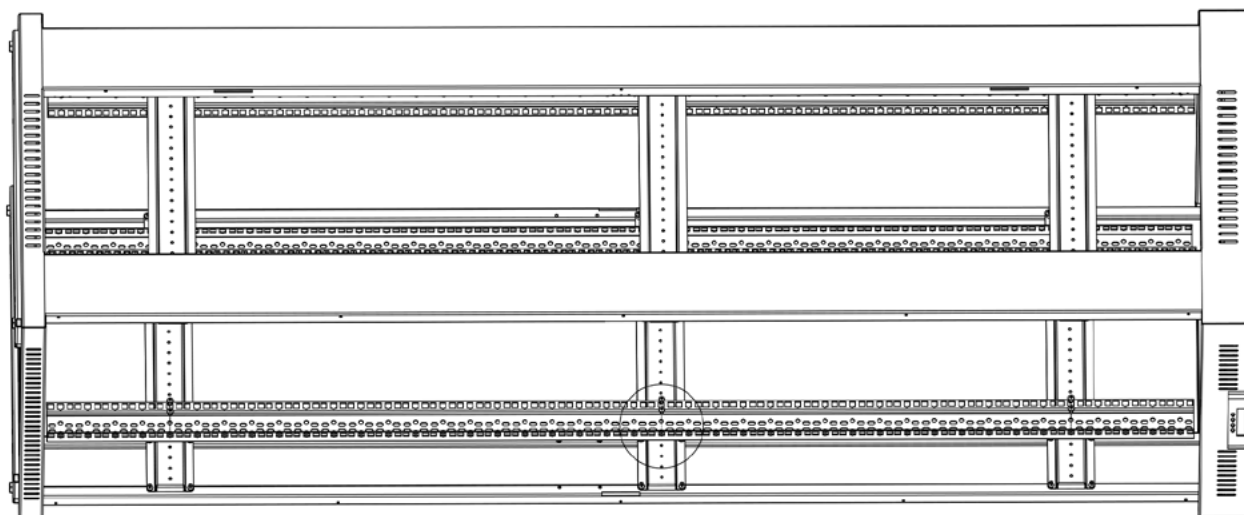
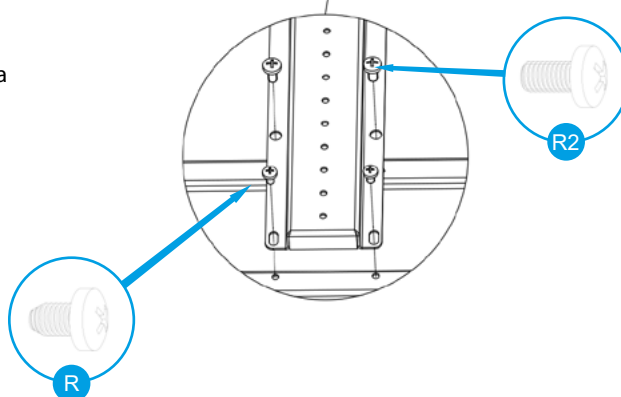

Lépés 6. Készítsen elő egy M5*10 önmetsző csavart (R) a függőleges szerelősínek (I) vízszintes keresztmervítőkhoz (G) történő rögzítéséhez.

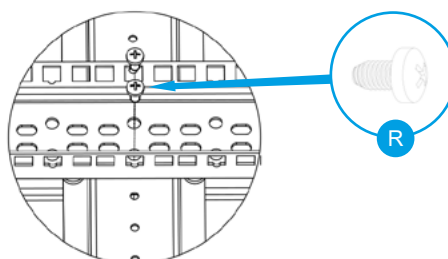

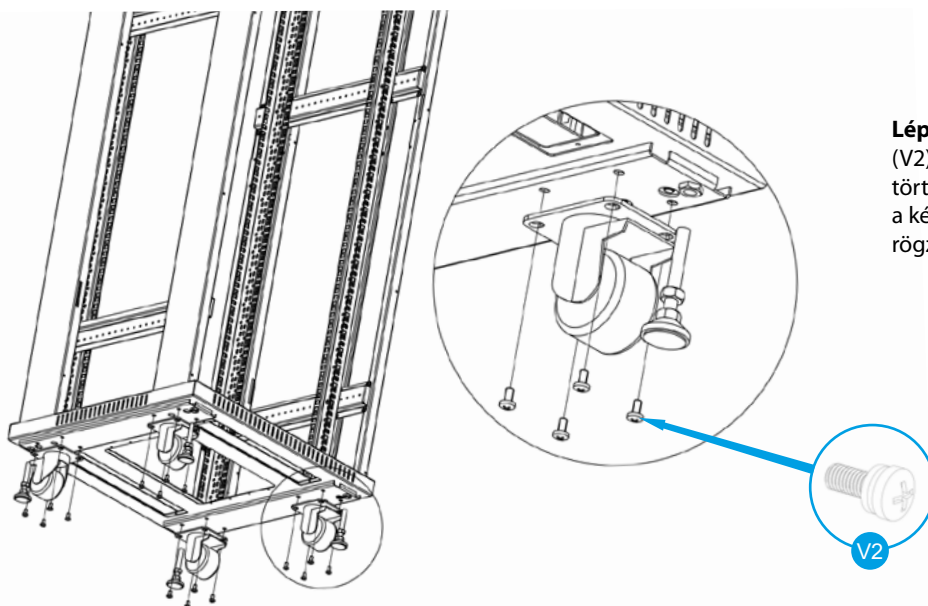

Lépés 7. Készítsen elő alátétes csavarokat (V2) a négy görgő (L) alsó fedélhez (F) történő rögzítéséhez. A görgők helyett a készletben található lábakat (K) is rögzítheti a fedélhez.

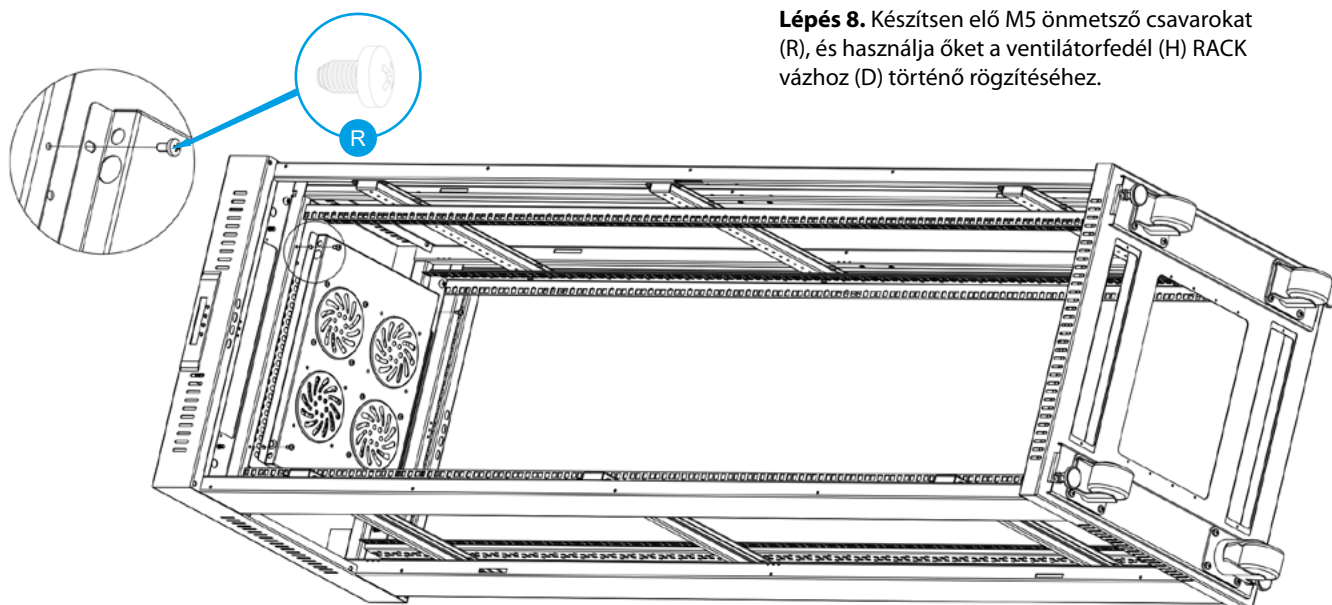

Lépés 8. Készítsen elő M5 önmetsző csavarokat (R), és használja őket a ventilátorfedél (H) RACK vázhoz (D) történő rögzítéséhez.

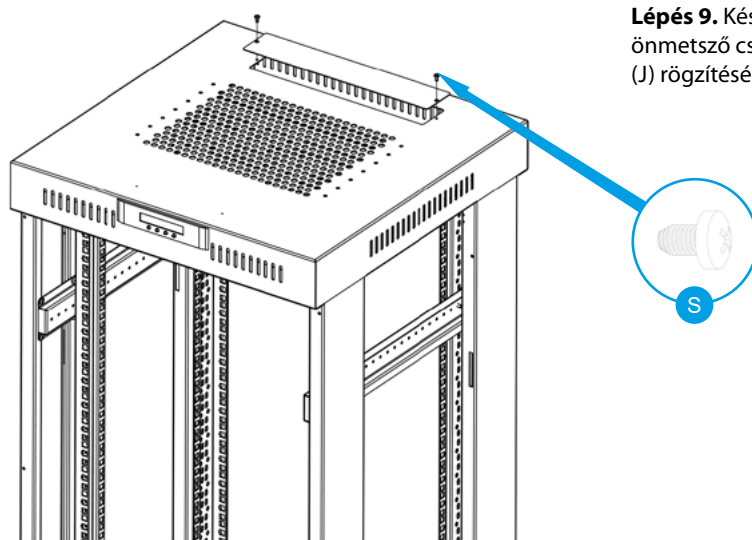

Lépés 9. Készítsen elő és használjon egy M4 önmetsző csavart (S) a felső panel kupakjának (J) rögzítéséhez.

Lépés 10. Készítsen elő és használjon M4
önmetsző csavarokat (S) az ajtóütközők (M)
rögzítéséhez, 12U~27U(8pcs), 32U~47U(12pcs)



Lépés 11. Készítse elő és helyezze a megfelelő helyekre az ajtóávtartókat (W)
az első ajtóhoz és a hátsó panelhez (items A és B). Az oldalpaneleket (C) csak
a legvégén szerelje fel.

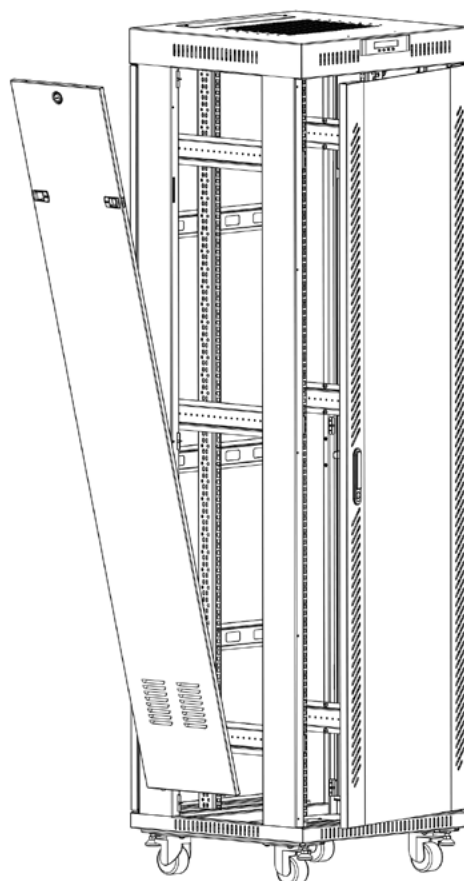
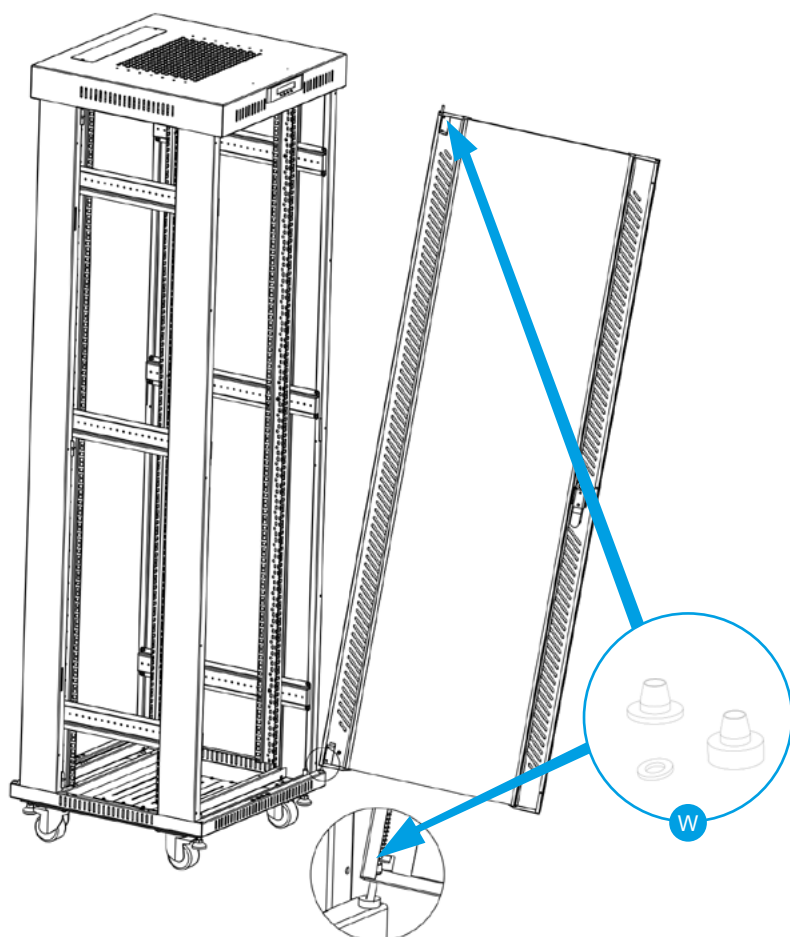
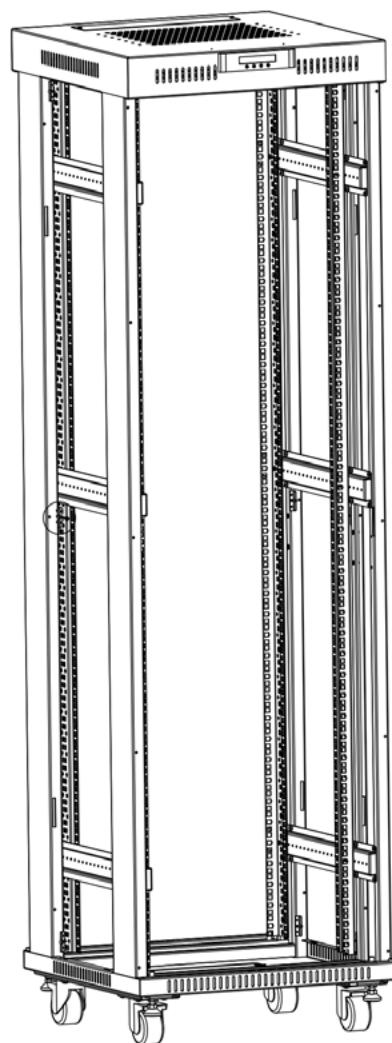









1. Montaža





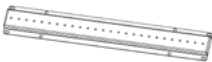
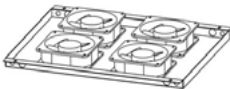

Obavezno se strogo pridržavajte uputstava iz ovog priručnika.







1.1 Priprema

Pripremite dovoljno slobodnog prostora na površini na kojoj će se vršiti montaža. Pažljivo izvadite sve elemente iz transportne kutije. Dalja uputstva za montažu zasnivače se na priloženom dijagramu.

1.1.1. Tabela komponenti

Elementi ormara		
Br. stavke	Crtež	Isporučena količina
A		1
B		1
C		2
D		2
E		1
F		1
G		15U~27U 4 32U~47U 6
H		1
I		4
J		3 4

K		4
L		4
M		15U~27U 8 32U~47U 12
N		1
O		3
W		4

Vijci			
Br. stavke	Crtež	Isporučena količina	
Q		17	
R		15U~27U	38
		32U~47U	54
S		15U~27U	24
		32U~47U	28
R2		15U~27U	18
		32U~47U	26
V		20	
V2		17	

2. Koraci instalacije

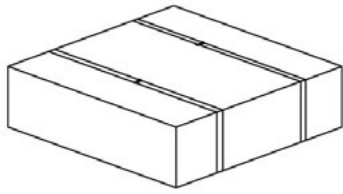

GORNJI I DONJI DEO - PAKET
1/3

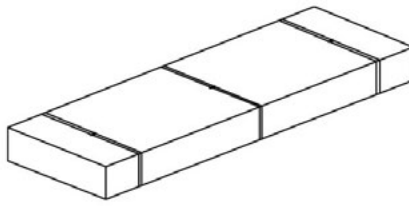

PREDNJA, ZADNJA I BOČNA
VRATA - PAKET 2/3

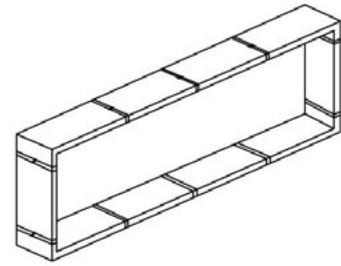

RAM - PAKET 3/3

Korak 1. Uklonite bravu prednjih vrata (N), brave bočnih panela i bravu zadnjeg panela (O); komponente se nalaze u paketu 1/3. Zatim izvadite prednja staklena vrata (A), zadnji panel (B) i bočne panele (C) iz paketa 2/3. U ovoj fazi počinjemo montažu brava na gore navedene komponente.

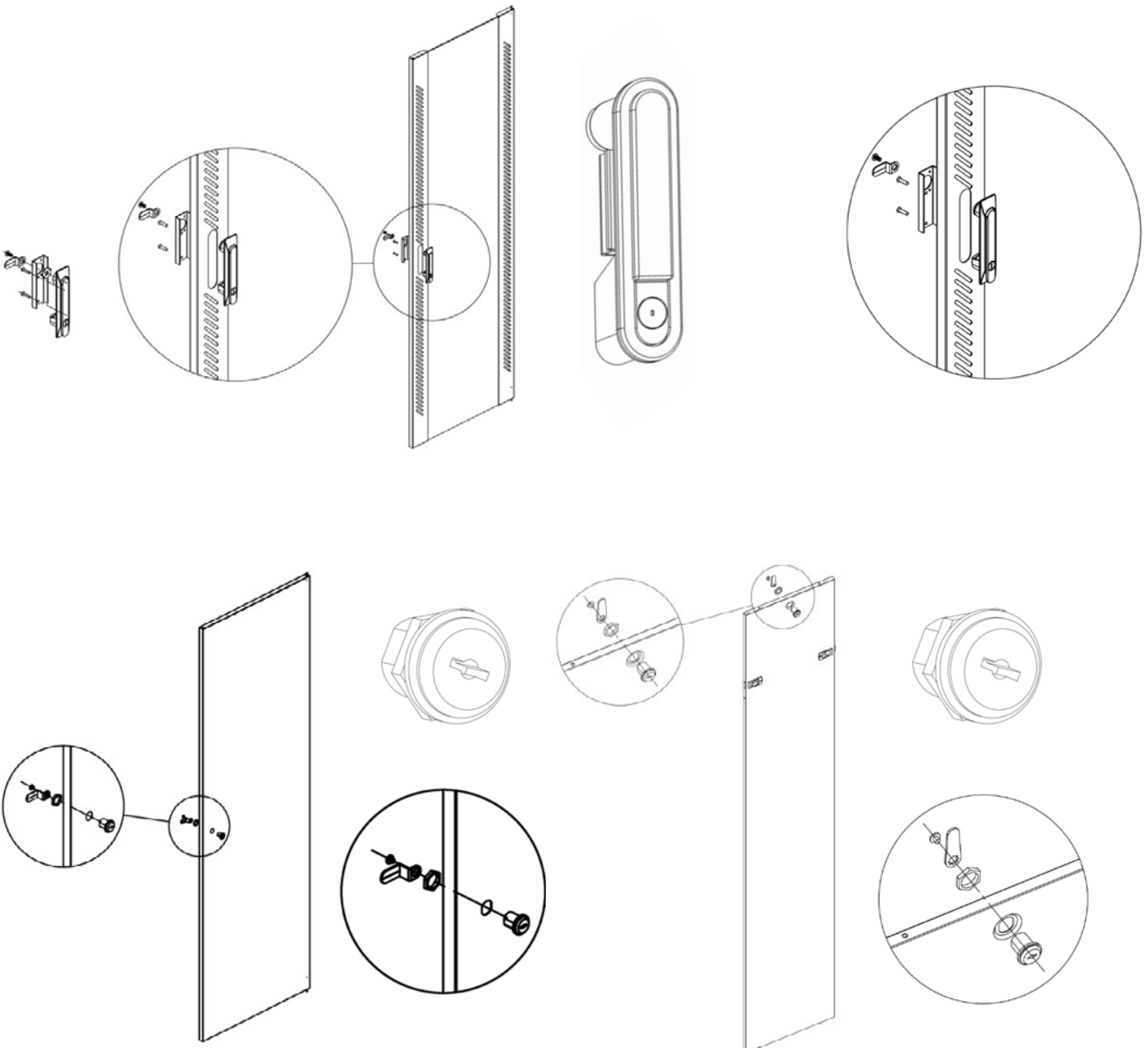

Korak 2. Raspakujte delove rama (D) iz paketa 3/3. Zatim postavite ramove paralelno jedan uz drugi, tako da kvadratni otvori budu okrenuti ka unutra. Donji deo rama možete prepoznati po elementima za uzemljenje.

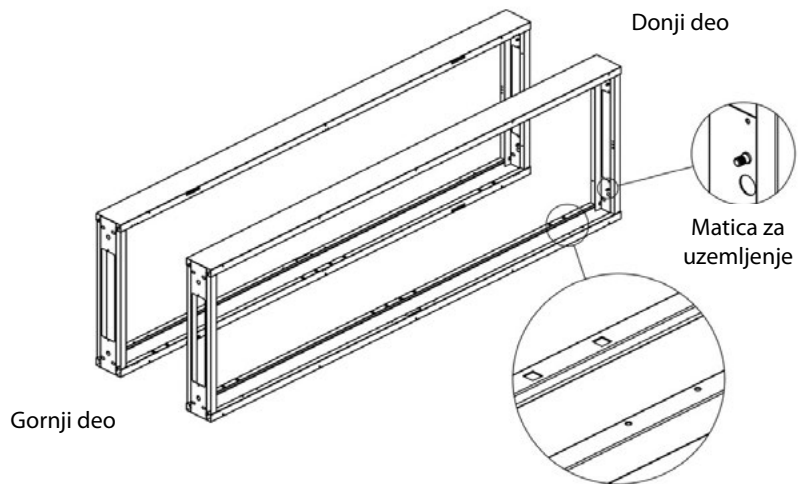

Korak 3. Postavite gornji poklopac (E) na gornje delove rama (D), a zatim ih spojite pomoću M8 imbus vijka (Q).

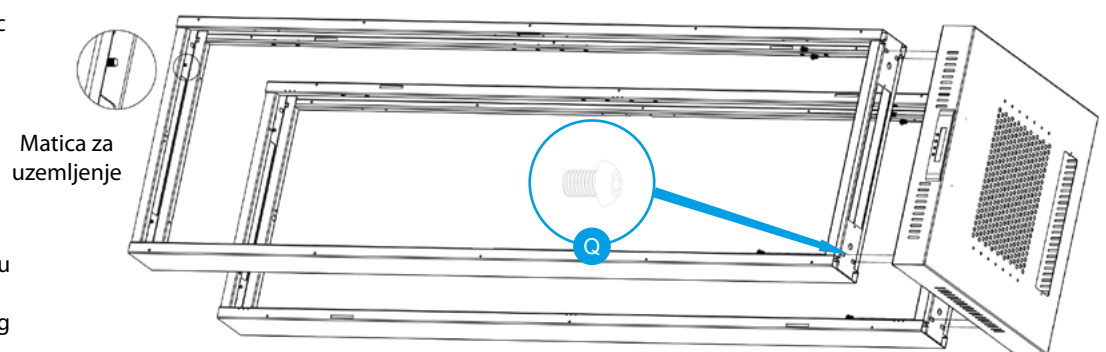

Napomena: Ramovi treba da budu montirani na poklopac tako da sa unutrašnje strane nema slobodnog razmaka između rama i poklopca.

Korak 4. Postavite donji poklopac (F) na donji deo rama (D) i upotrebite M8 imbus vijak (Q) da ih spojite.

Napomena: Ramovi treba da budu montirani na poklopac tako da sa unutrašnje strane nema slobodnog razmaka između rama i poklopca.

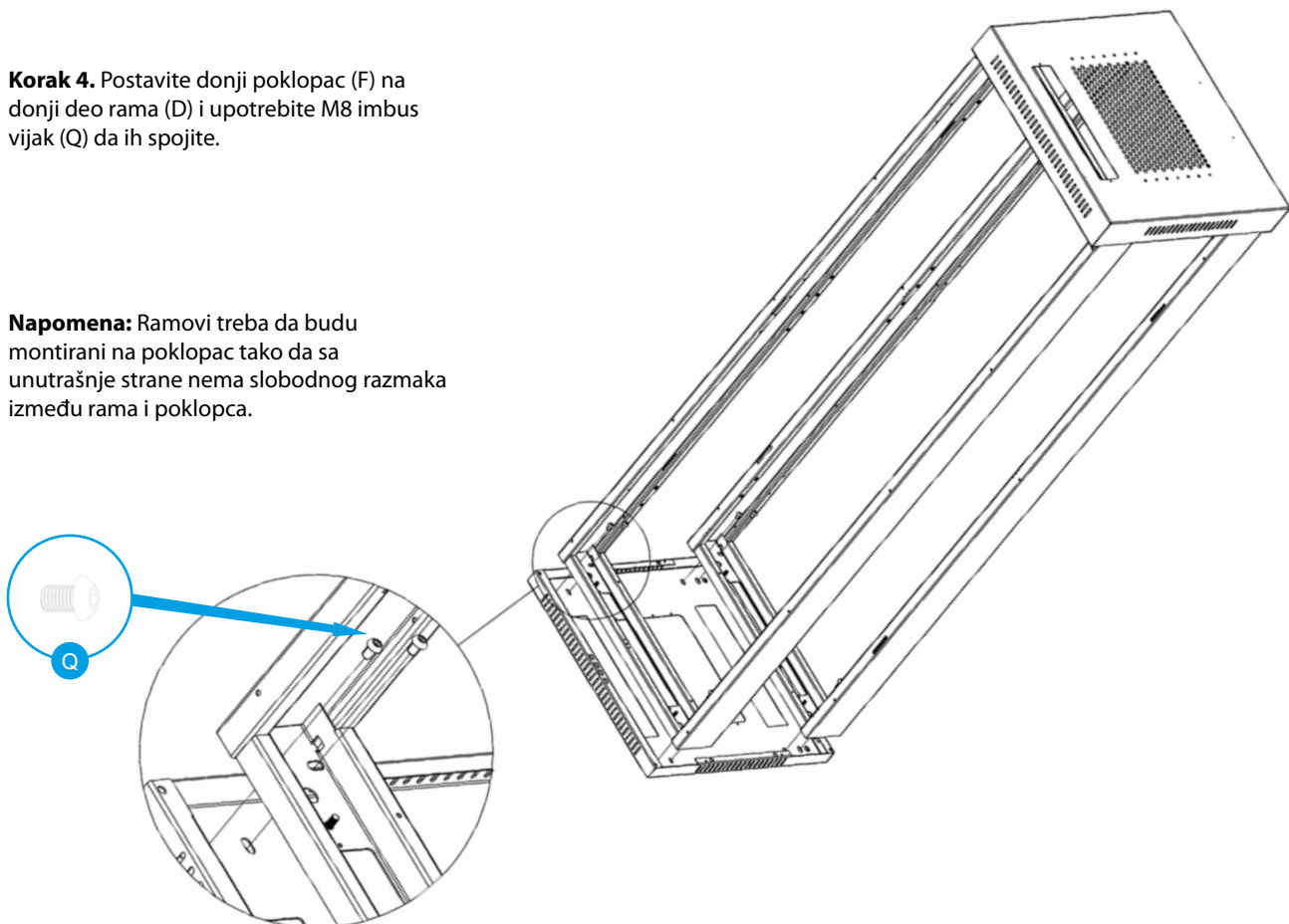

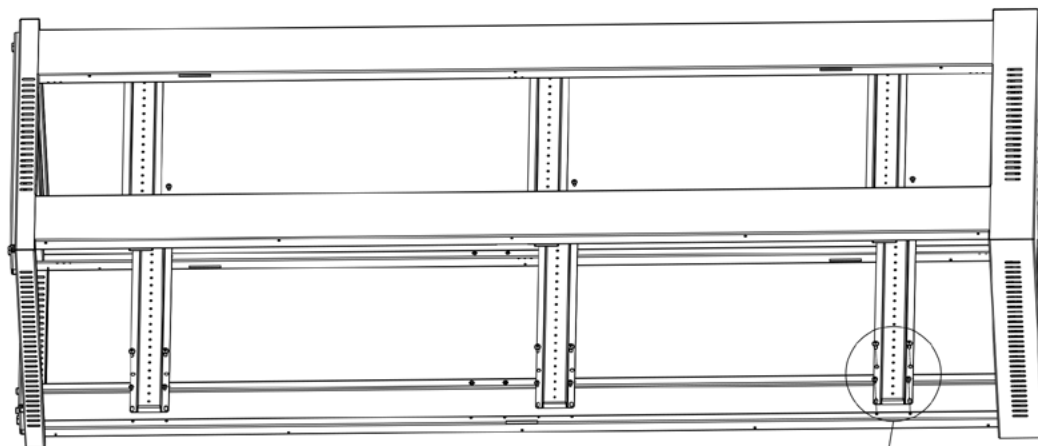

Korak 5. Postavite prečku (G) na ram (D), izbegavajući otvor predviđen za bravu. Upotrebite M5*10 vijak (R2) i M5 samourezujući vijak (R) da pričvrstite prečku.

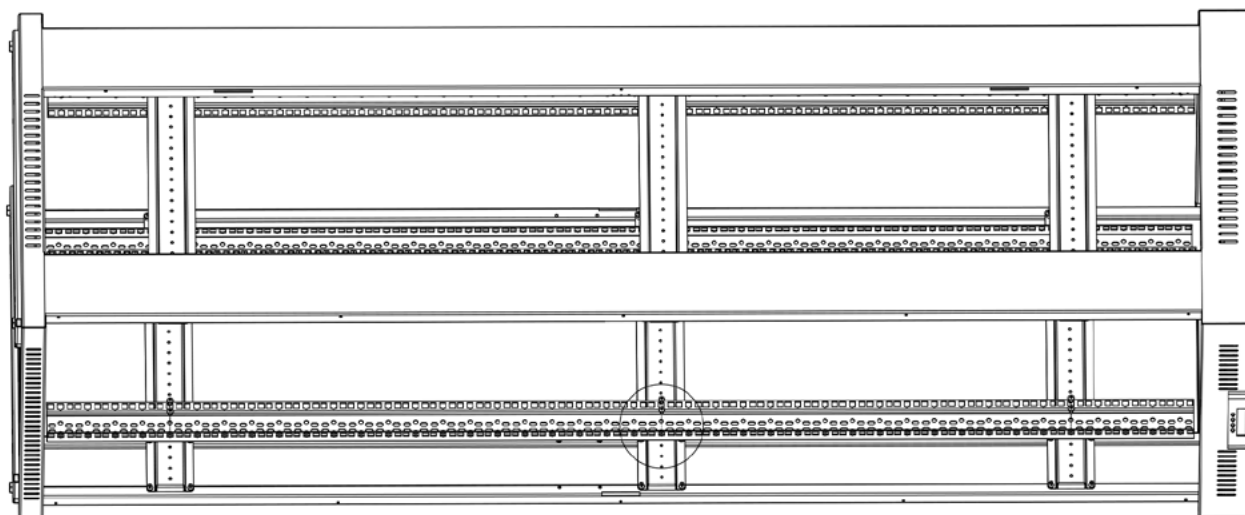
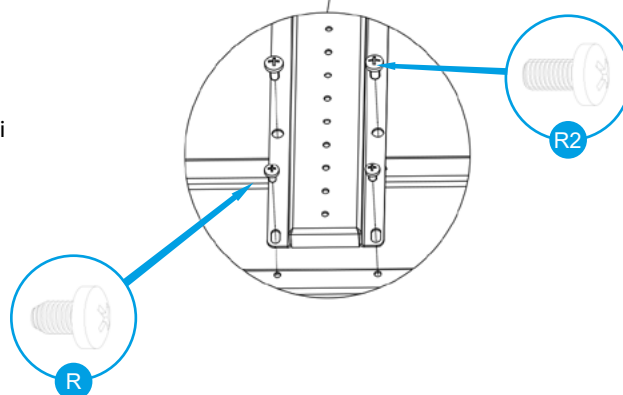

Korak 6. Pripremite M5*10 samourezujući vijak (R) za pričvršćivanje vertikalnih montažnih šina (I) na horizontalne prečke (G).

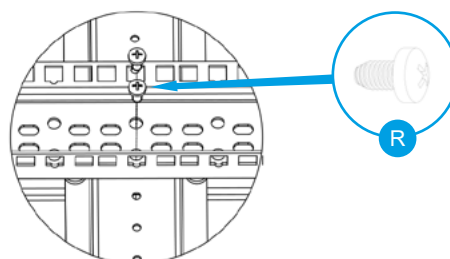

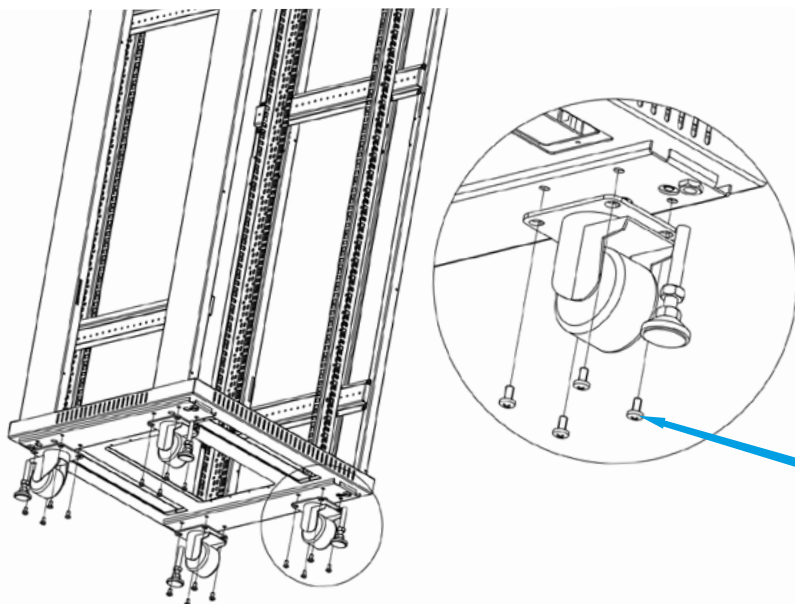

Korak 7. Pripravite vijke sa podloškom (V2) za pričvršćivanje četiri točkića (L) na donji poklopac (F). Umesto točkića, na poklopac možete pričvrstiti i nožice (K) koje su uključene u komplet.

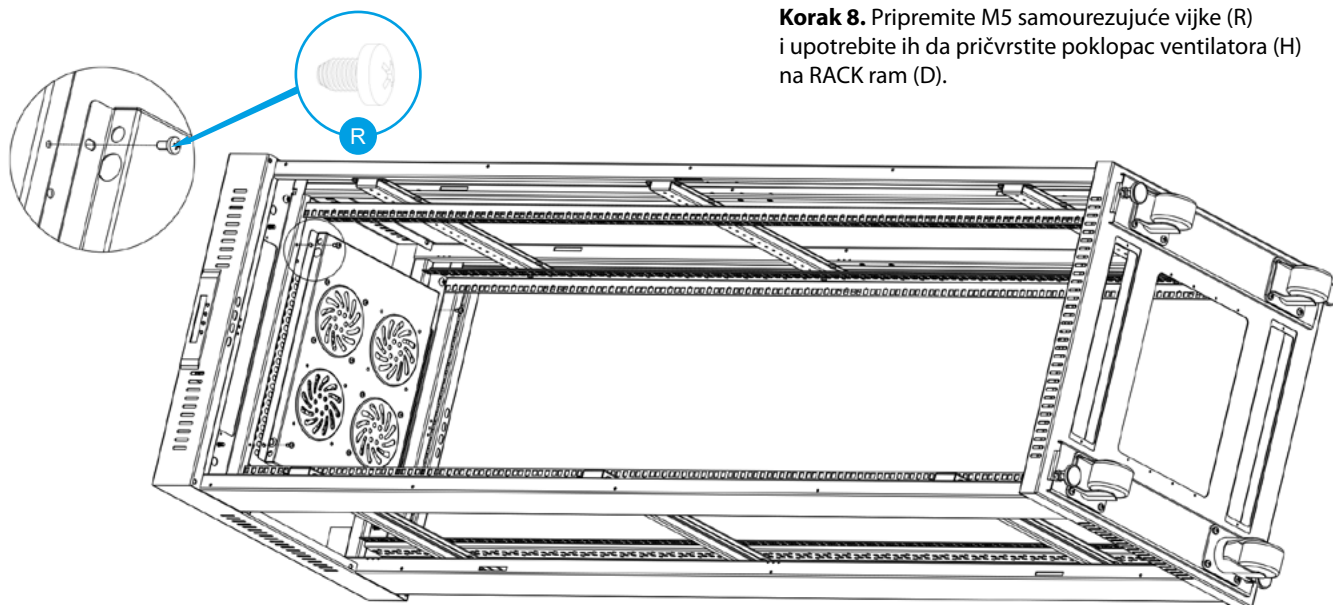

Korak 8. Pripravite M5 samourezujuće vijke (R) i upotrebite ih da pričvrstite poklopac ventilatora (H) na RACK ram (D).

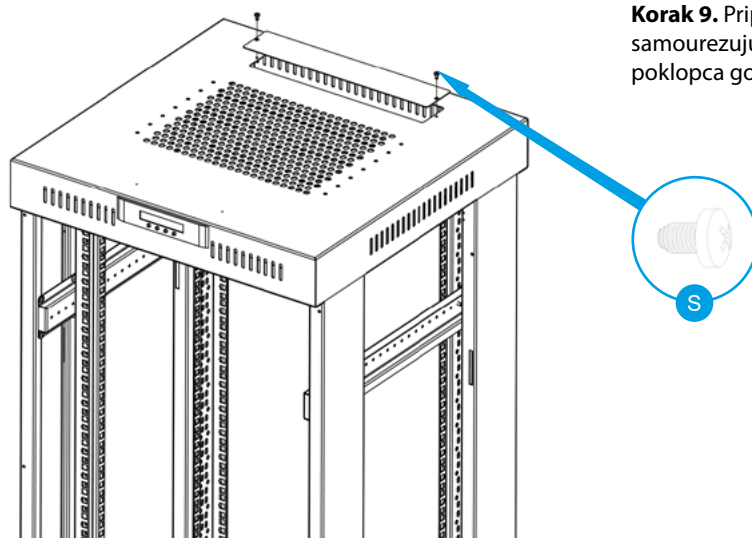

Korak 9. Pripravite i upotrebite M4 samourezujući vijak (S) za pričvršćivanje poklopca gornjeg panela (J).

Korak 10. Pripravite i upotrebite M4 samourezujuće vijke (S) za pričvršćivanje graničnika vrata (M), 12U~27U (8), 32U~47U (12).

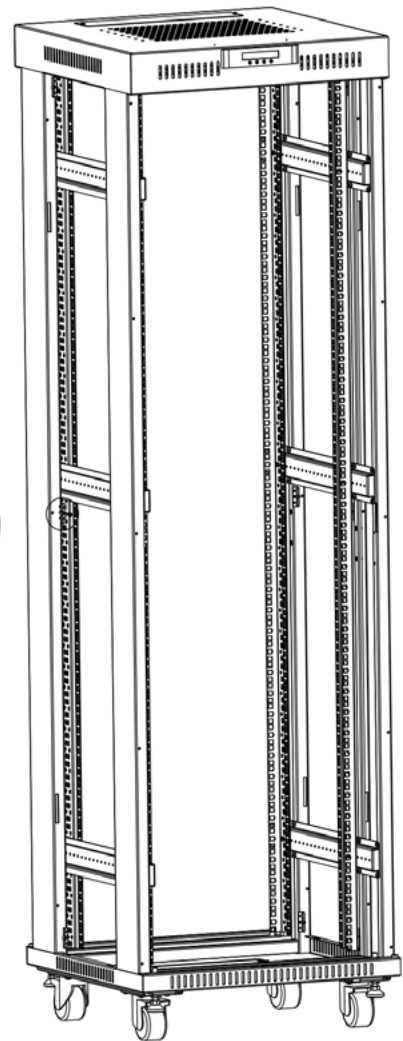

Korak 11. Pripravite i postavite odstoynike vrata (W) za prednja vrata i zadnji panel (A i B) na odgovarajuća mesta. Bočne panele (C) montirajte tek na samom kraju.

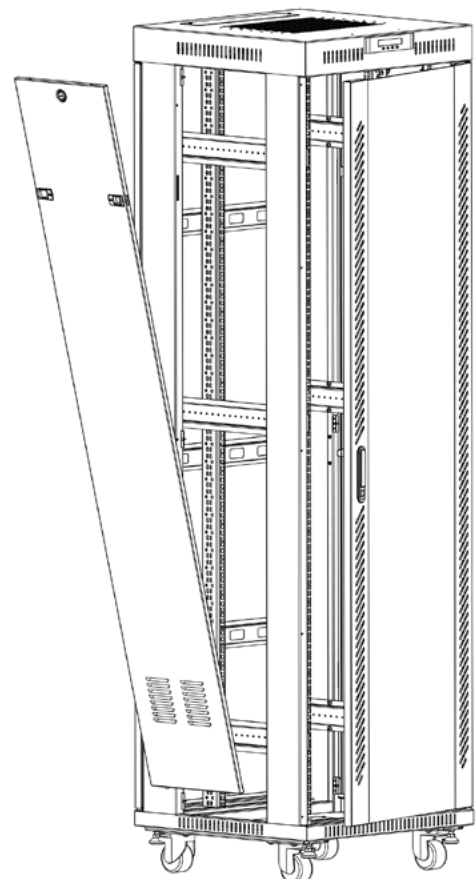
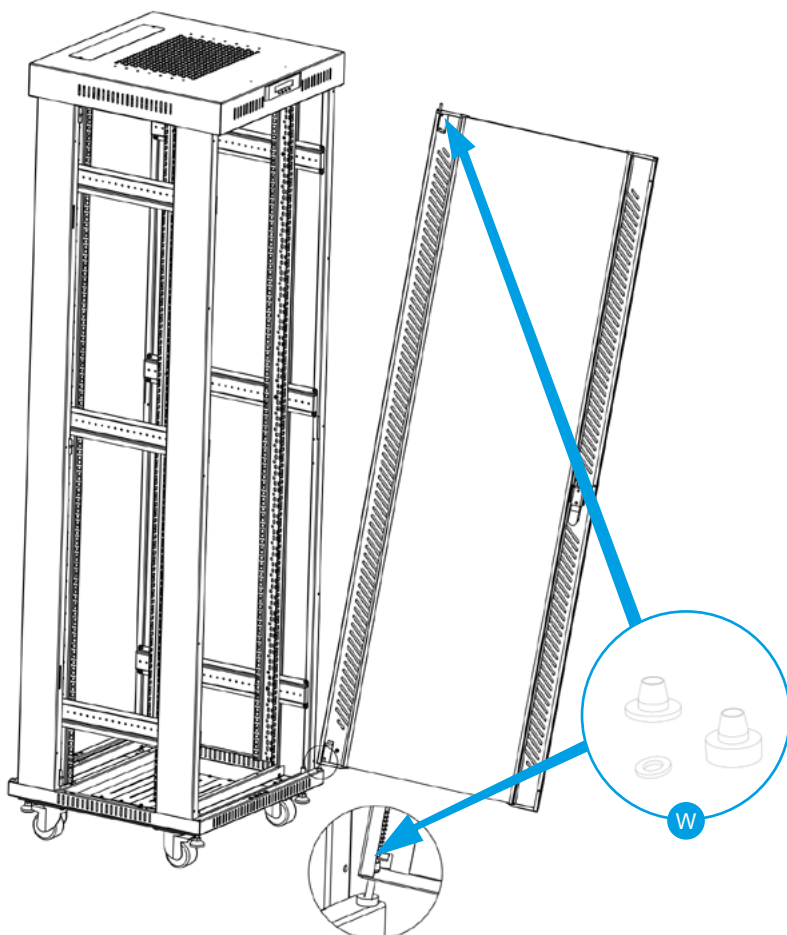









1. Сборка





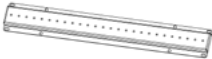
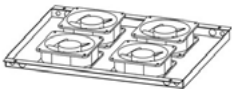

Обязательно строго следуйте инструкциям, приведенным в данном руководстве.







1.1 Подготовка

Подготовьте достаточное количество свободного места на поверхности, на которой будет выполняться сборка. Осторожно извлеките все элементы из транспортной коробки. Дальнейшие инструкции по сборке будут основаны на приведенной схеме.

1.1.1. Таблица компонентов

Элементы шкафа		
№ поз.	Чертёж	Количество в комплекте
A		1
B		1
C		2
D		2
E		1
F		1
G		15U~27U 4 32U~47U 6
H		1
I		4
J		3 4

K		4
L		4
M		15U~27U 8 32U~47U 12
N		1
O		3
W		4

Винты			
№ поз.	Чертёж	Количество в комплекте	
Q		17	
R		15U~27U	38
		32U~47U	54
S		15U~27U	24
		32U~47U	28
R2		15U~27U	18
		32U~47U	26
V		20	
V2		17	

2. Этапы установки

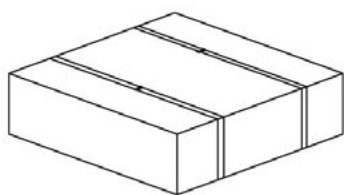

ВЕРХ И НИЗ - УПАКОВКА 1/3

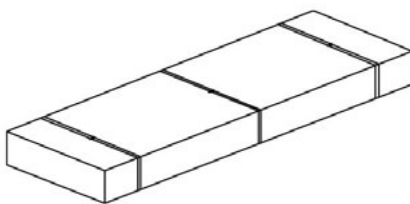

ПЕРЕДНЯЯ, ЗАДНЯЯ И
БОКОВЫЕ ДВЕРИ - УПАКОВКА
2/3

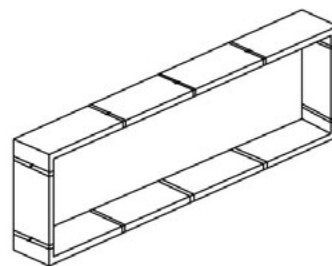

РАМА - УПАКОВКА 3/3

Шаг 1. Снимите замок передней двери (N), замки боковых панелей и замок задней панели (O); компоненты находятся в упаковке 1/3. Затем выньте переднюю стеклянную дверь (A), заднюю панель (B) и боковые панели (C) из упаковки 2/3. На этом этапе мы начинаем с установки замков на указанные выше компоненты.

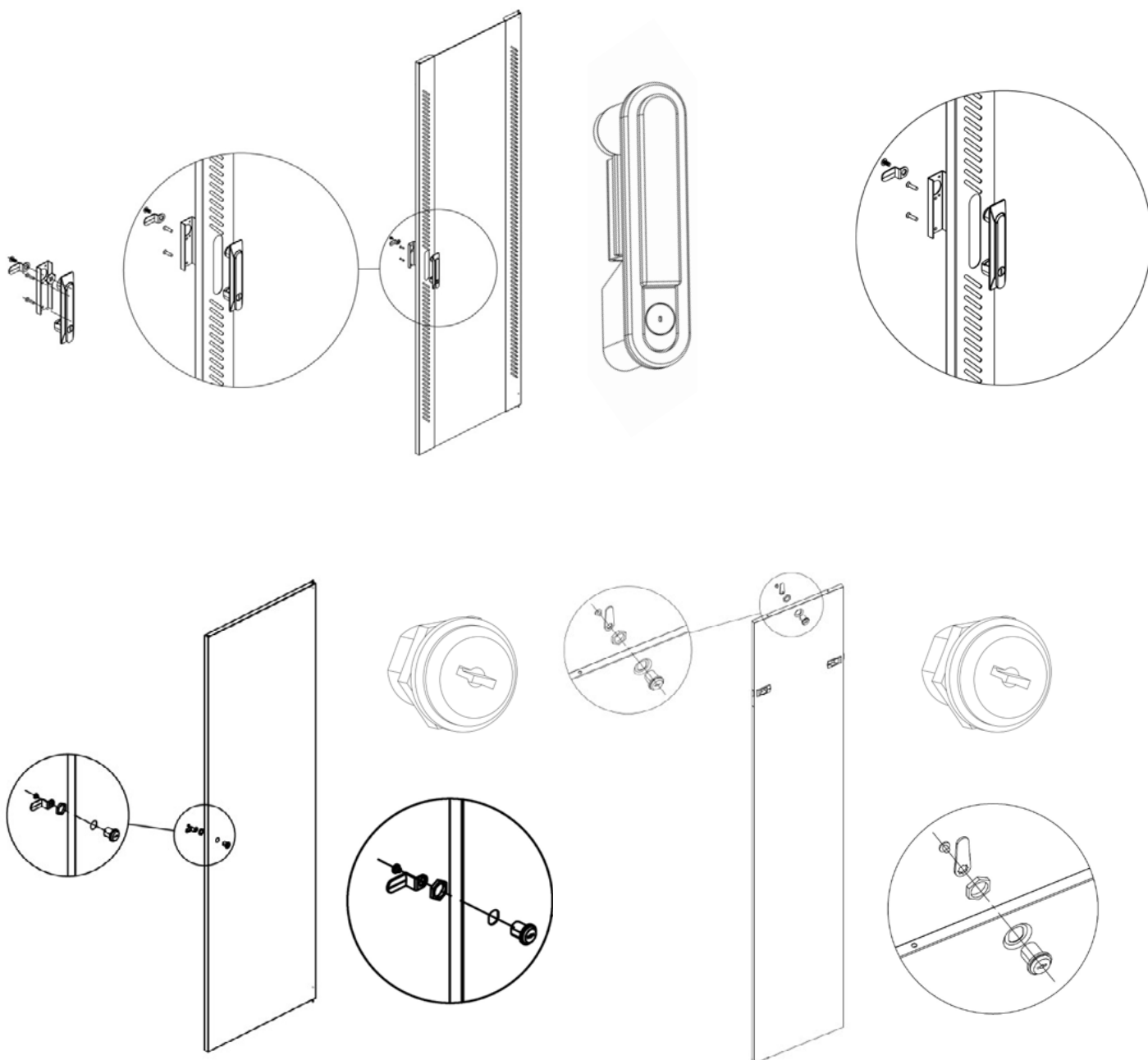

Шаг 2. Распакуйте части рамы (D) из упаковки 3/3. Затем расположите рамы параллельно друг другу так, чтобы квадратные отверстия были направлены внутрь. Нижнюю часть рамы можно определить по заземляющим элементам.

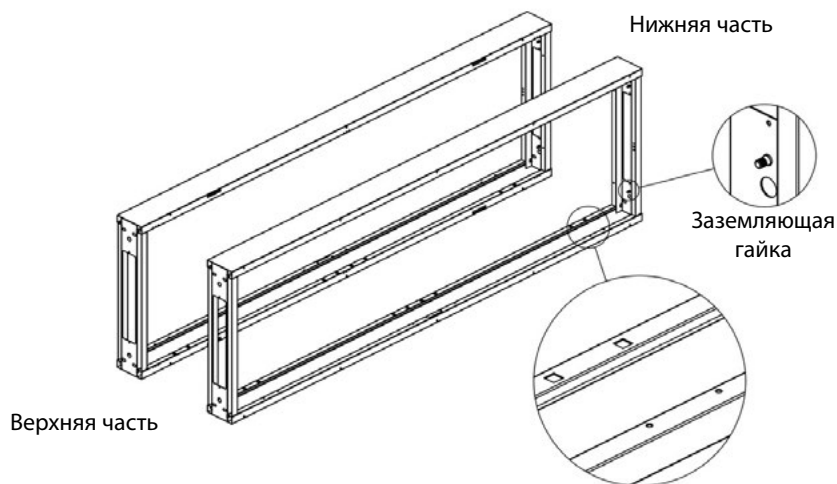

Шаг 3. Установите верхнюю крышку (E) на верхние части рамы (D), а затем соедините их винтом M8 с внутренним шестигранником (Q).

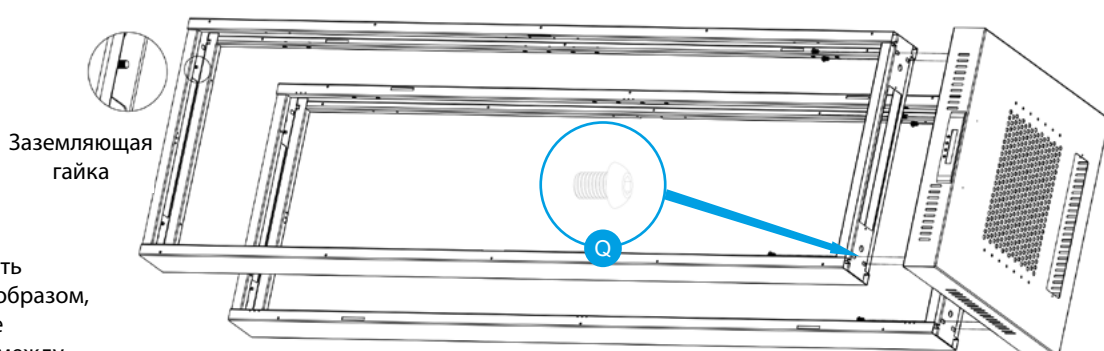

Примечание: Рамы должны быть установлены на крышке таким образом, чтобы с внутренней стороны не оставалось свободного зазора между рамой и крышкой.

Шаг 4. Установите нижнюю крышку (F) на нижнюю часть рамы (D) и используйте винт M8 с внутренним шестигранником (Q), чтобы соединить их.

Примечание: Рамы должны быть установлены на крышке таким образом, чтобы с внутренней стороны не оставалось свободного зазора между рамой и крышкой.

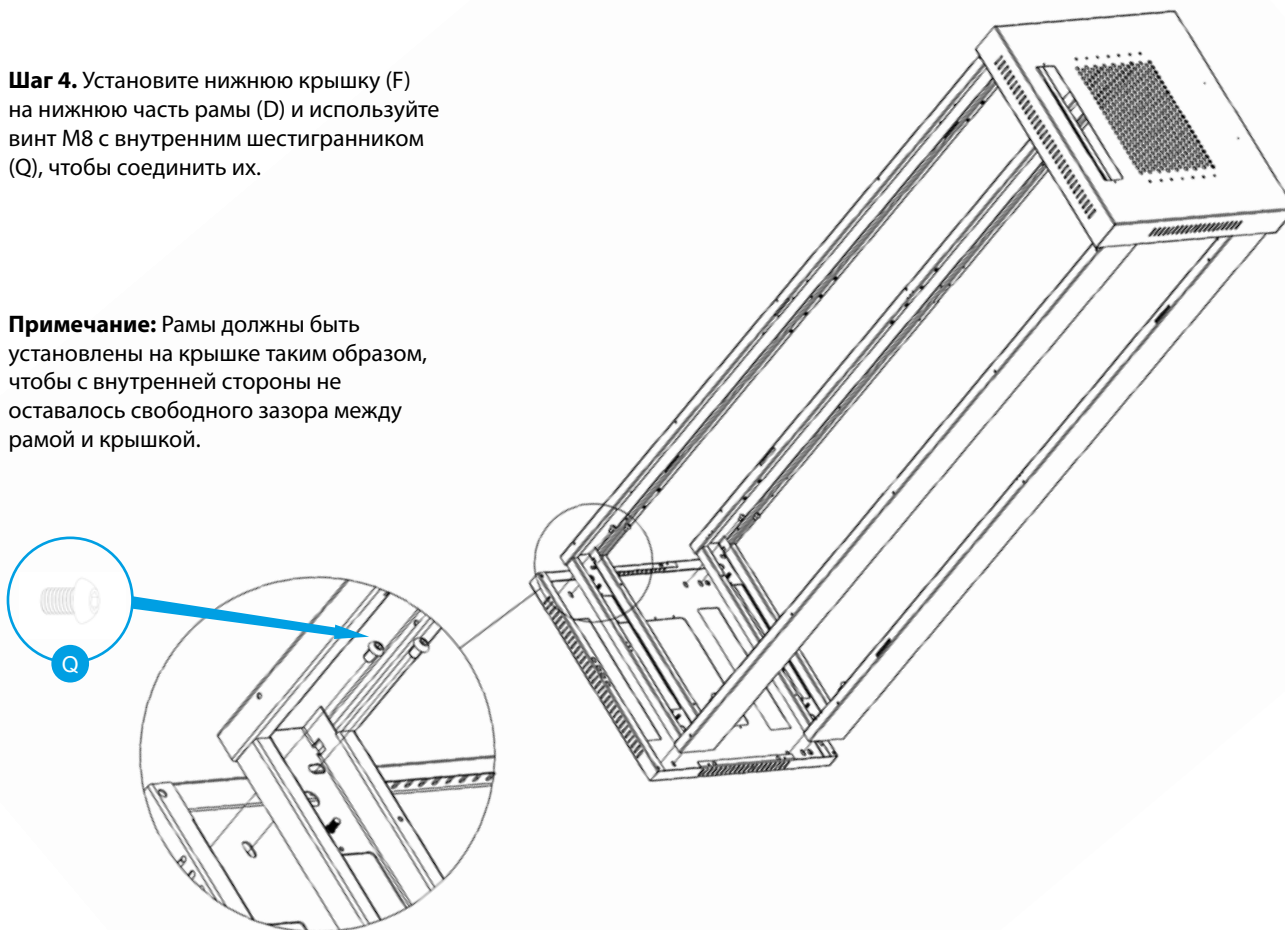

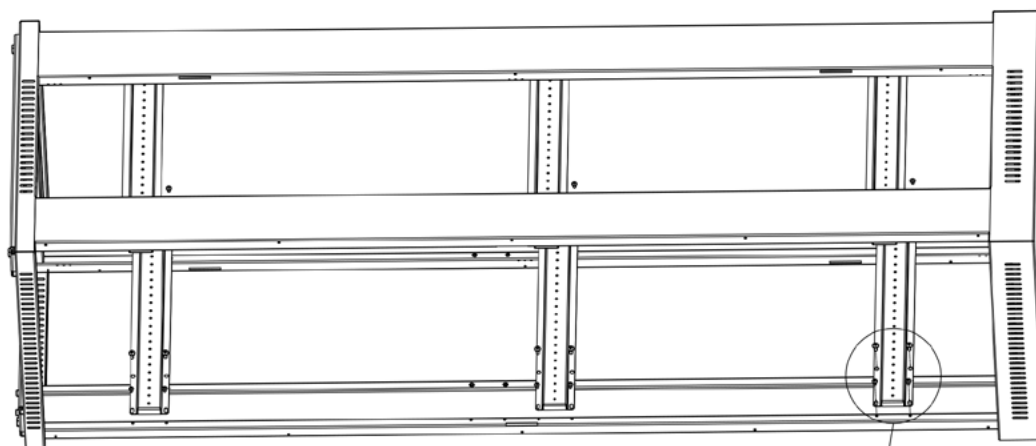

Шаг 5. Установите поперечину (G) на раму (D), избегая отверстия, предназначенного для замка. Используйте винт M5*10 (R2) и самонарезающий винт M5 (R), чтобы закрепить поперечину.

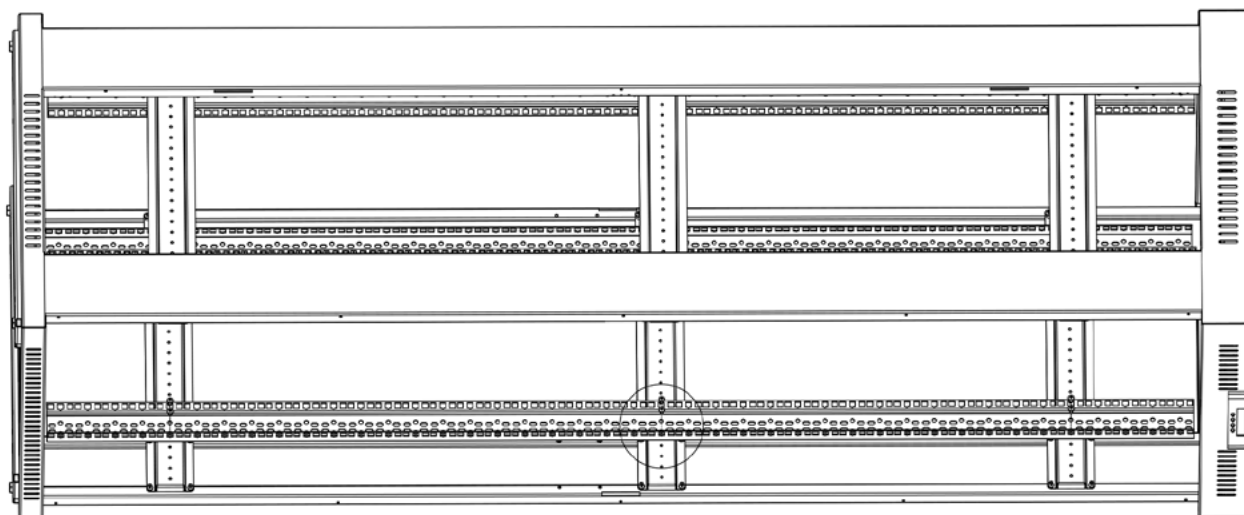
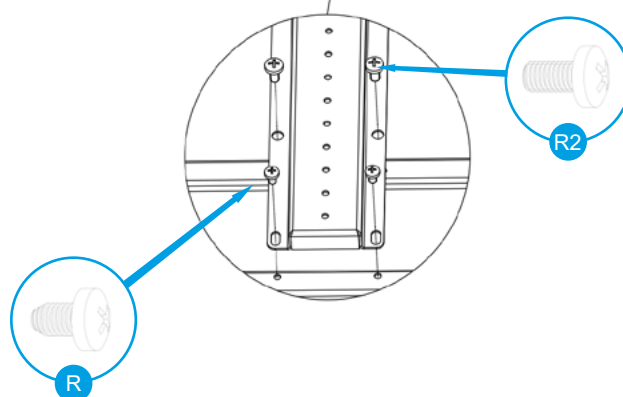

Шаг 6. Подготовьте самонарезающий винт M5*10 (R) для крепления вертикальных монтажных направляющих (I) к горизонтальным перекладинам (G).

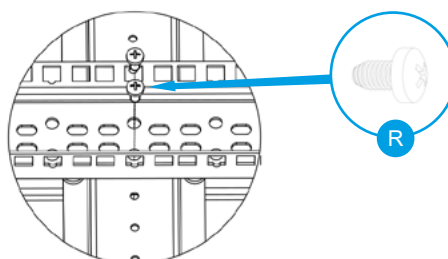

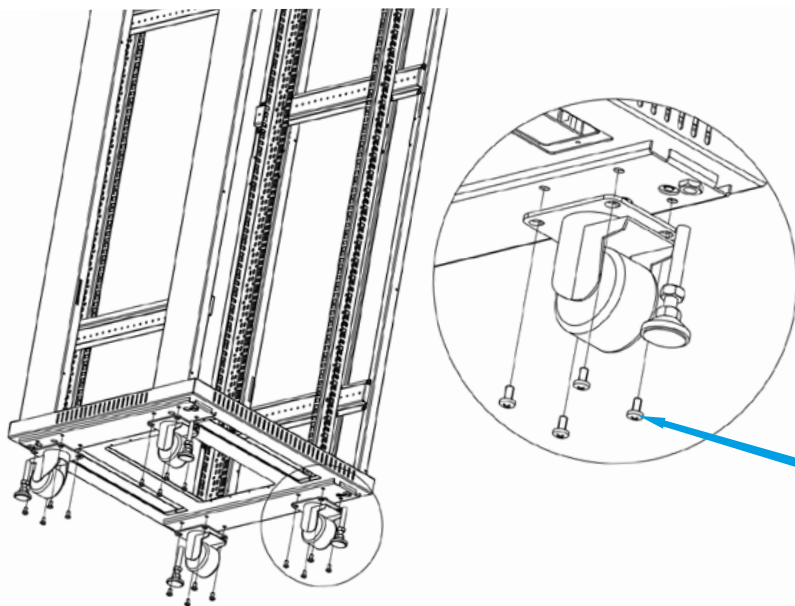

Шаг 7. Подготовьте винты с шайбой (V2) для крепления четырех колесиков (L) к нижней крышке (F). Вместо колесиков вы также можете закрепить на крышке ножки (K), входящие в комплект.

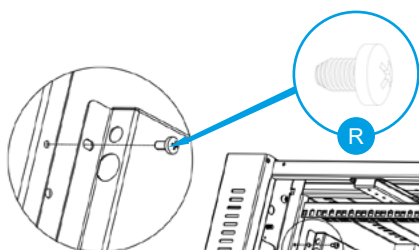
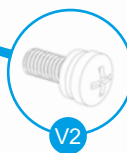

Шаг 8. Подготовьте самонарезающие винты M5 (R) и используйте их для крепления крышки вентилятора (H) к раме RACK (D).

R

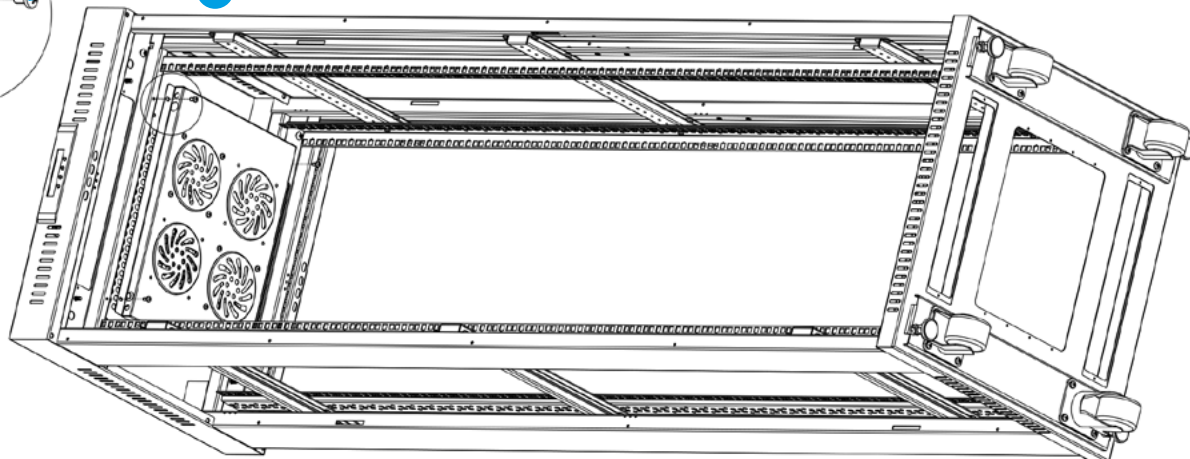

Шаг 9. Подготовьте и используйте самонарезающий винт M4 (S) для крепления крышки верхней панели (J).

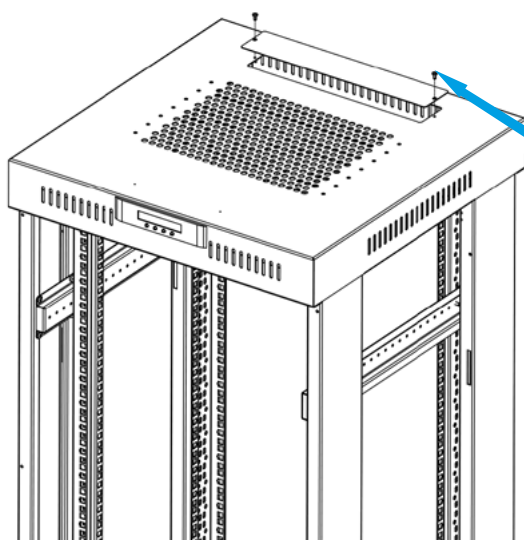

S

Шаг 10. Подготовьте и используйте самонарезающие винты M4 (S) для крепления дверных упоров (M), 12U~27U (8), 32U~47U (12).

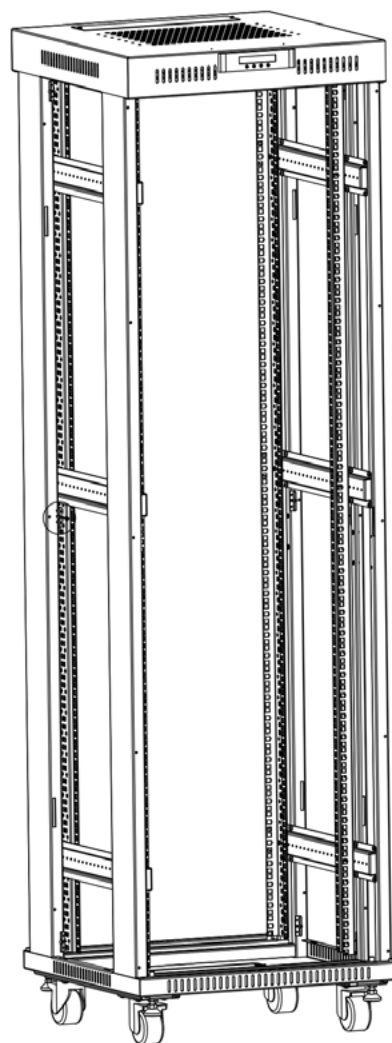
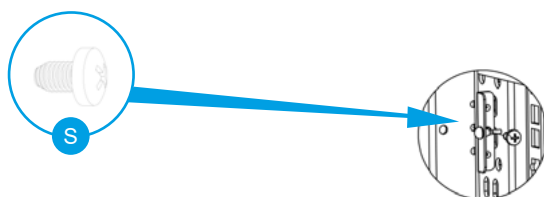

Шаг 11. Подготовьте и установите распорки двери (W) для передней двери и задней панели (items A и B) в соответствующие места. Боковые панели (C) устанавливайте в самом конце.

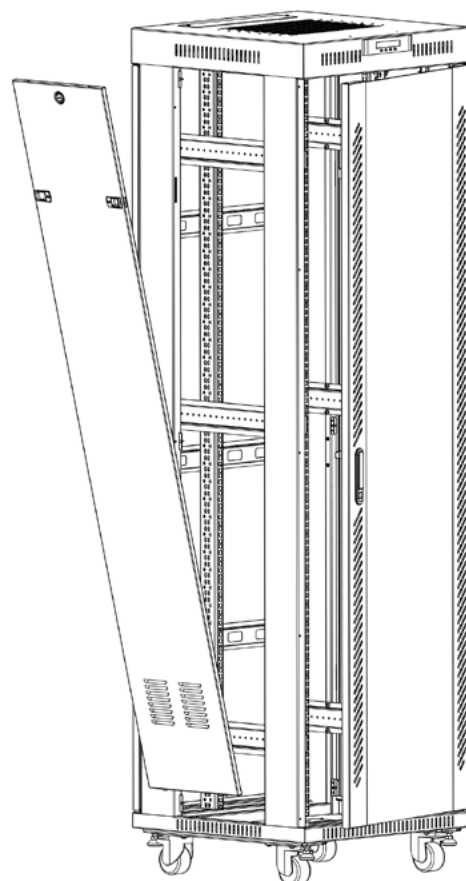
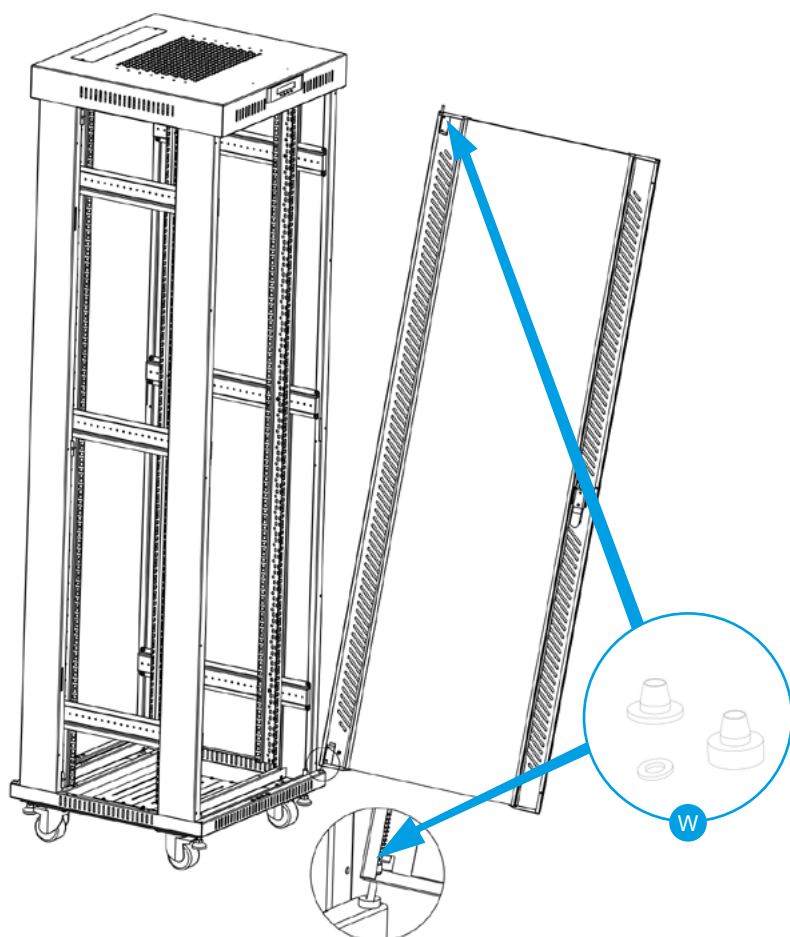







1. Συναρμολόγηση





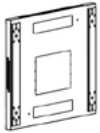
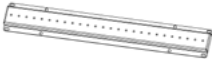
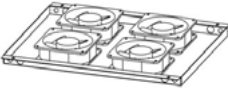

Βεβαιωθείτε ότι ακολουθείτε αυστηρά τις οδηγίες αυτού του εγχειριδίου.







1.1 Προετοιμασία

Προετοιμάστε επαρκή ελεύθερο χώρο στην επιφάνεια όπου θα πραγματοποιηθεί η συναρμολόγηση. Αφαιρέστε προσεκτικά όλα τα στοιχεία από το κιβώτιο μεταφοράς. Οι επόμενες οδηγίες συναρμολόγησης θα βασίζονται στο παρεχόμενο διάγραμμα.

1.1.1. Πίνακας εξαρτημάτων

Στοιχεία ερμαρίου		
Αρ. είδους	Σχέδιο	Παρεχόμενη ποσότητα
A		1
B		1
C		2
D		2
E		1
F		1
G		15U~27U 4 32U~47U 6
H		1
I		4
J		3 4

K		4
L		4
M		15U~27U 8 32U~47U 12
N		1
O		3
W		4

Βίδες			
Αρ. είδους	Σχέδιο	Παρεχόμενη ποσότητα	
Q		17	
R		15U~27U	38
		32U~47U	54
S		15U~27U	24
		32U~47U	28
R2		15U~27U	18
		32U~47U	26
V		20	
V2		17	

2. Βήματα εγκατάστασης

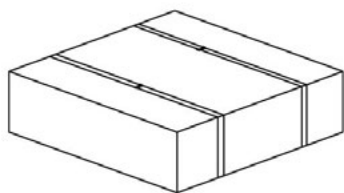

ΠΑΝΩ ΚΑΙ ΚΑΤΩ ΜΕΡΟΣ -
ΣΥΣΚΕΥΑΣΙΑ 1/3

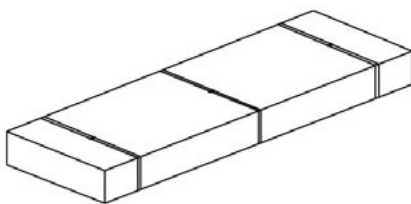

ΜΠΡΟΣΤΙΝΗ, ΠΙΣΩ ΚΑΙ ΠΛΑΪΝΕΣ
ΠΟΡΤΕΣ - ΣΥΣΚΕΥΑΣΙΑ 2/3

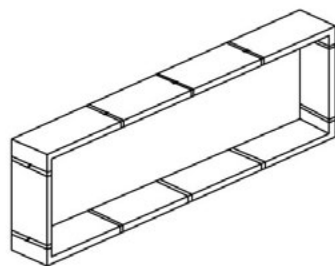

ΠΛΑΙΣΙΟ - ΣΥΣΚΕΥΑΣΙΑ 3/3

Βήμα 1. Αφαιρέστε την κλειδαριά της μπροστινής πόρτας (N), τις κλειδαριές των πλαϊνών πάνελ και την κλειδαριά του πίσω πάνελ (O). Τα εξαρτήματα βρίσκονται στη συσκευασία 1/3. Στη συνέχεια αφαιρέστε τη γυάλινη μπροστινή πόρτα (A), το πίσω πάνελ (B) και τα πλαϊνά πάνελ (C) από τη συσκευασία 2/3. Σε αυτό το στάδιο ξεκινάμε με την τοποθέτηση των κλειδαριών στα παραπάνω εξαρτήματα.

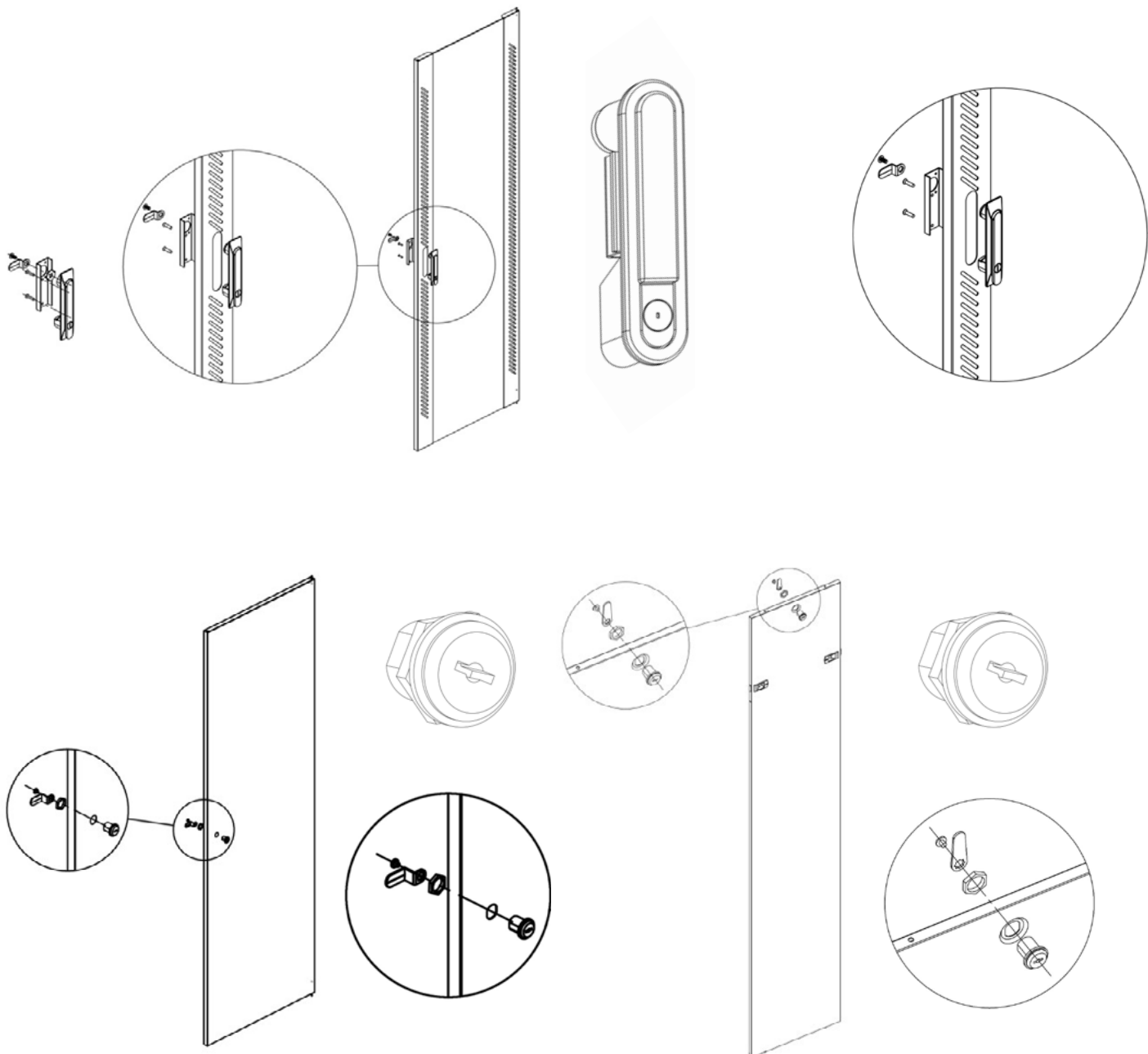

Βήμα 2. Αποσυναρμολογήστε τα μέρη του πλαισίου (D) από τη συσκευασία 3/3. Στη συνέχεια τοποθετήστε τα πλαίσια παράλληλα μεταξύ τους, με τις τετράγωνες οπές στραμμένες προς τα μέσα. Μπορείτε να αναγνωρίσετε το κάτω μέρος του πλαισίου από τα εξαρτήματα γείωσης.

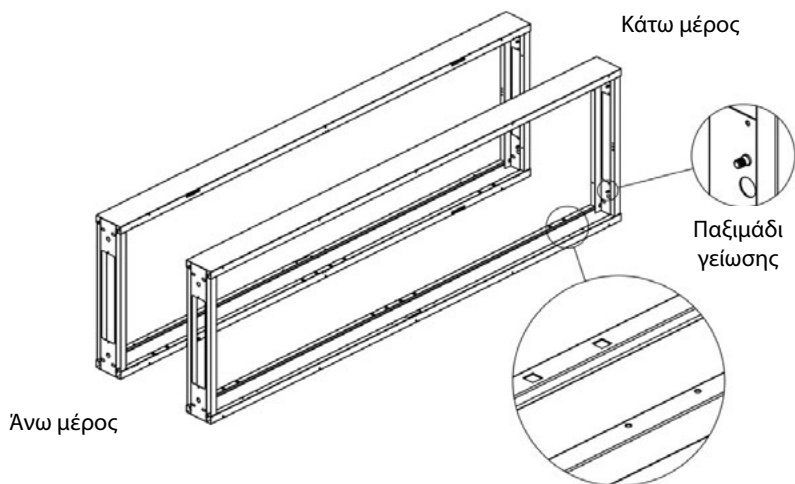

Βήμα 3. Τοποθετήστε το επάνω κάλυμμα (E) στα επάνω μέρη του πλαισίου (D) και στη συνέχεια συνδέστε τα με μία βίδα Allen M8 (Q)

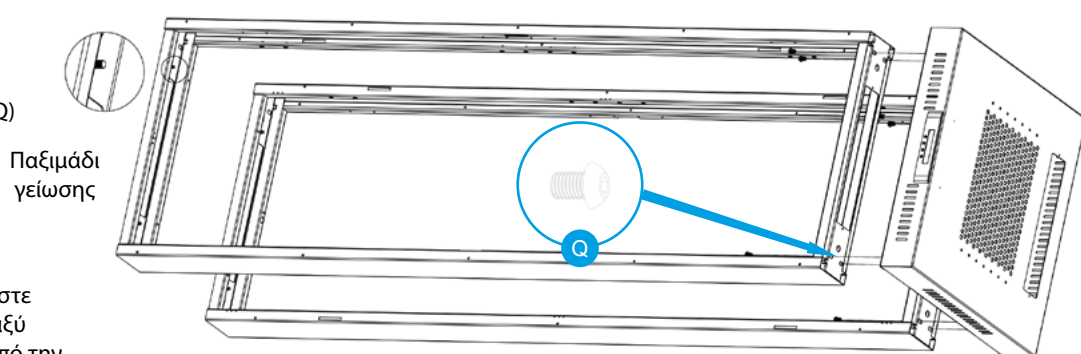

Σημείωση: Τα πλαίσια πρέπει να τοποθετούνται στο κάλυμμα έτσι ώστε να μην υπάρχει ελεύθερο κενό μεταξύ του πλαισίου και του καλύμματος από την εσωτερική πλευρά.

Βήμα 4. Τοποθετήστε το κάτω κάλυμμα (F) στο κάτω μέρος του πλαισίου (D) και χρησιμοποιήστε τη βίδα Allen M8 (Q) για να τα συνδέσετε.

Σημείωση: Τα πλαίσια πρέπει να τοποθετούνται στο κάλυμμα έτσι ώστε να μην υπάρχει ελεύθερο κενό μεταξύ του πλαισίου και του καλύμματος από την εσωτερική πλευρά.

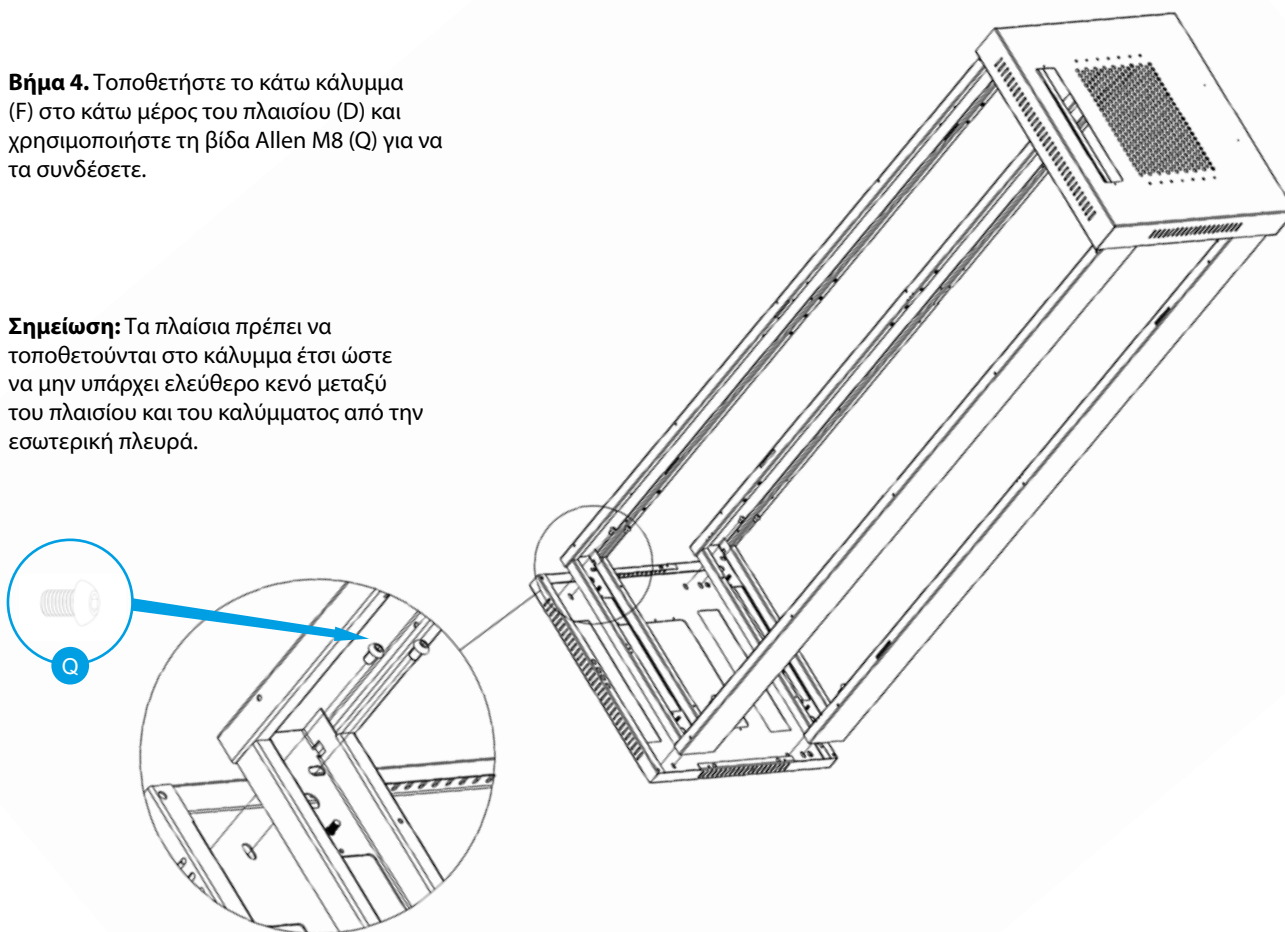

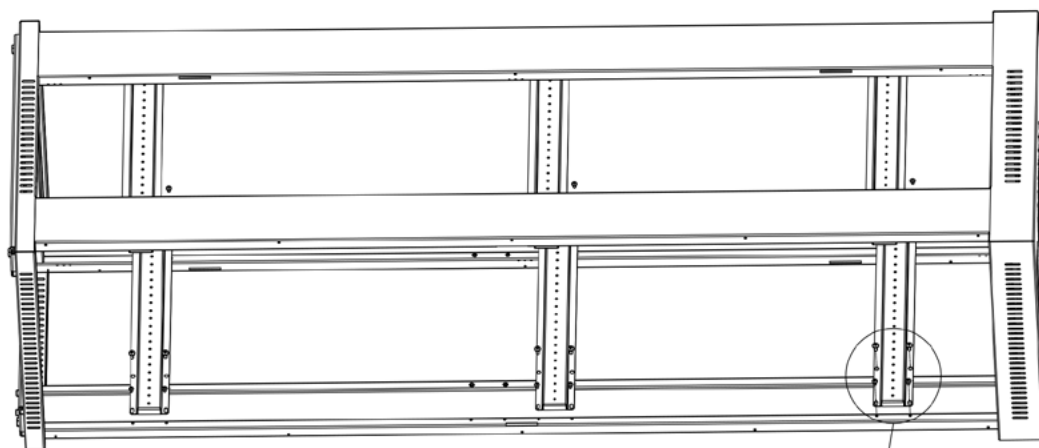

Βήμα 5. Τοποθετήστε την εγκάρσια δοκό (G) στο πλαίσιο (D), αποφεύγοντας την οπή που προορίζεται για την κλειδαριά. Χρησιμοποιήστε μία βίδα M5*10 (R2) και μία αυτοδιάτρητη βίδα M5 (R) για να στερεώσετε την εγκάρσια δοκό.

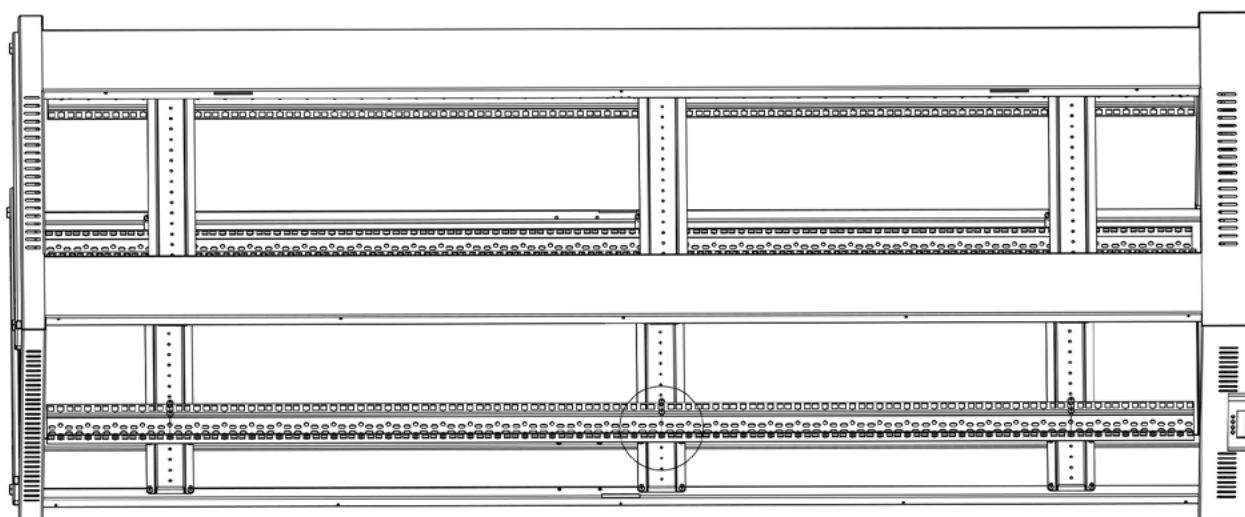
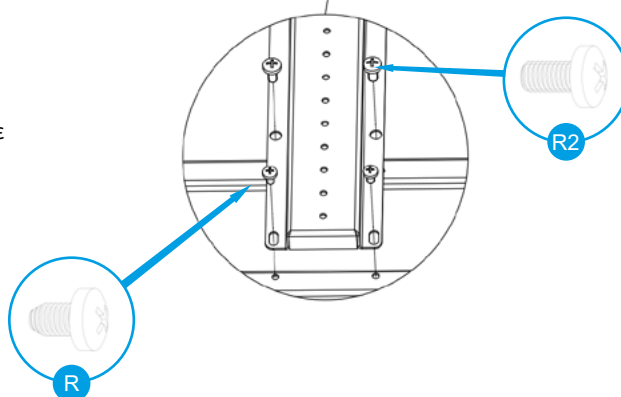

Βήμα 6. Προετοιμάστε μία αυτοδιάτρητη βίδα M5*10 (R) για να στερεώσετε τις κάθετες ράγες στήριξης (I) στις οριζόντιες δοκούς (G).

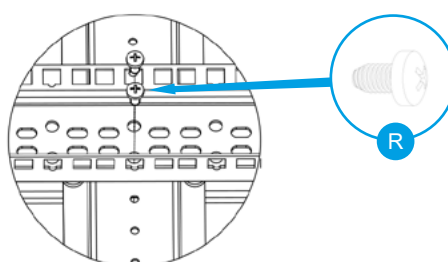

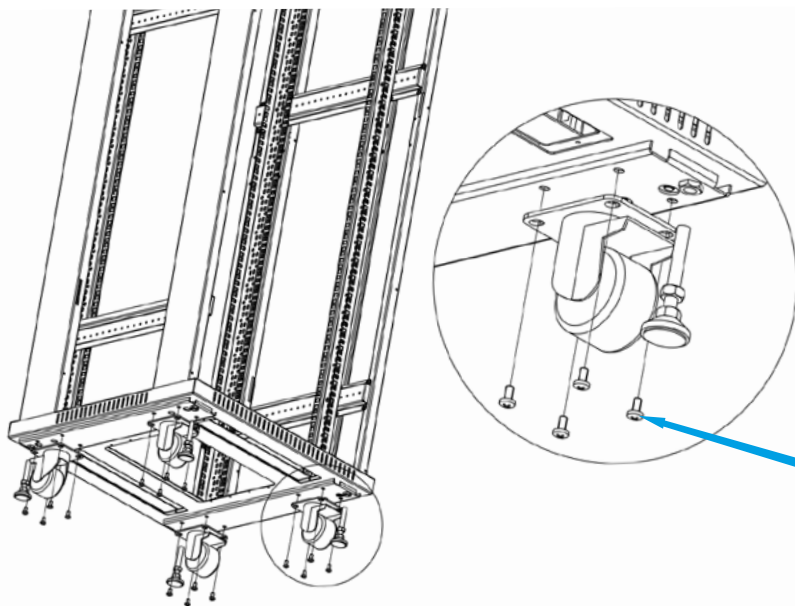

Βήμα 7. Προετοιμάστε βίδες με ροδέλα (V2) για να στερεώσετε τους τέσσερις τροχούς (L) στο κάτω κάλυμμα (F). Εναλλακτικά, αντί για τους τροχούς, μπορείτε να στερεώσετε στο κάλυμμα τα ποδαράκια (K) που περιλαμβάνονται στο κιτ.

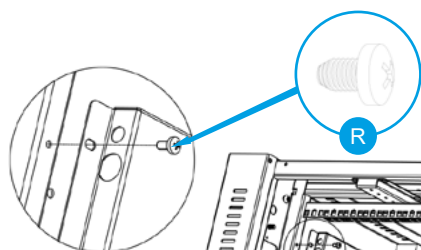
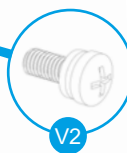

Βήμα 8. Προετοιμάστε αυτοδιάτρητες βίδες M5 (R) και χρησιμοποιήστε τις για να στερεώσετε το κάλυμμα του ανεμιστήρα (H) στο πλαίσιο RACK (D).

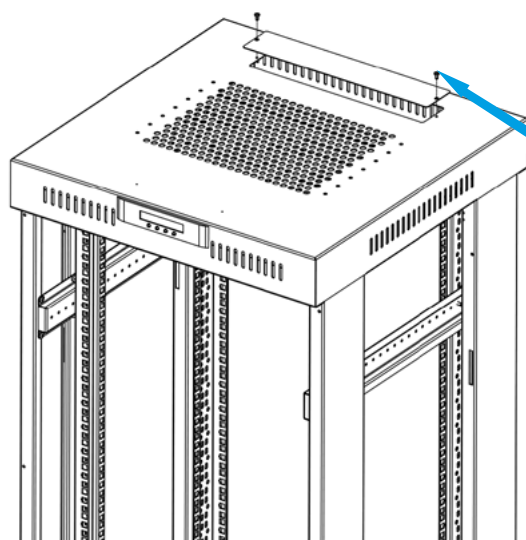
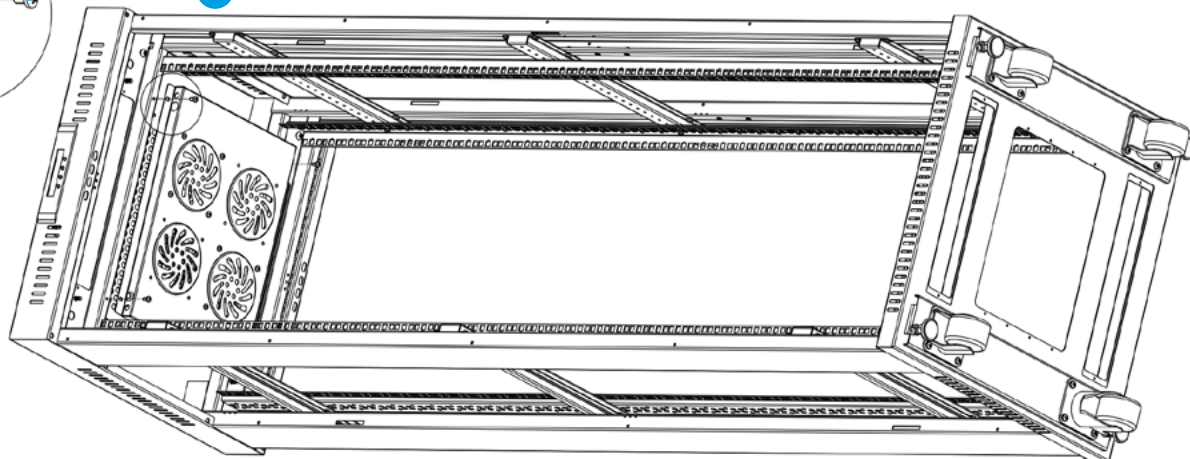

Βήμα 9. Προετοιμάστε και χρησιμοποιήστε μία αυτοδιάτρητη βίδα M4 (S) για να στερεώσετε το καπάκι του επάνω πάνελ (J).

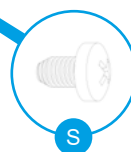

Βήμα 10. Προετοιμάστε και χρησιμοποιήστε αυτοδιάτρητες βίδες M4 (S) για να στερεώσετε τα στοπ της πόρτας (M), 12U~27U (8), 32U~47U (12).

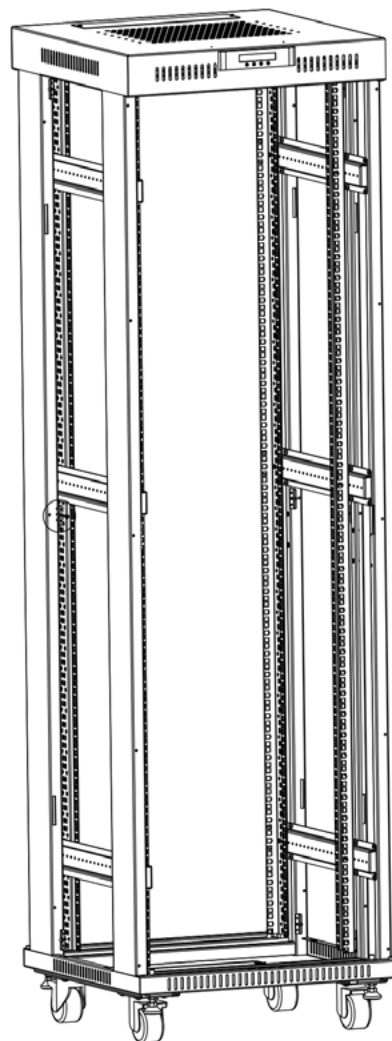

Βήμα 11. Προετοιμάστε και τοποθετήστε τους αποστάτες της πόρτας (W) για την μπροστινή πόρτα και το πίσω πάνελ (items A και B) στις κατάλληλες θέσεις. Τοποθετήστε τα πλαϊνά πάνελ (C) στο τέλος.

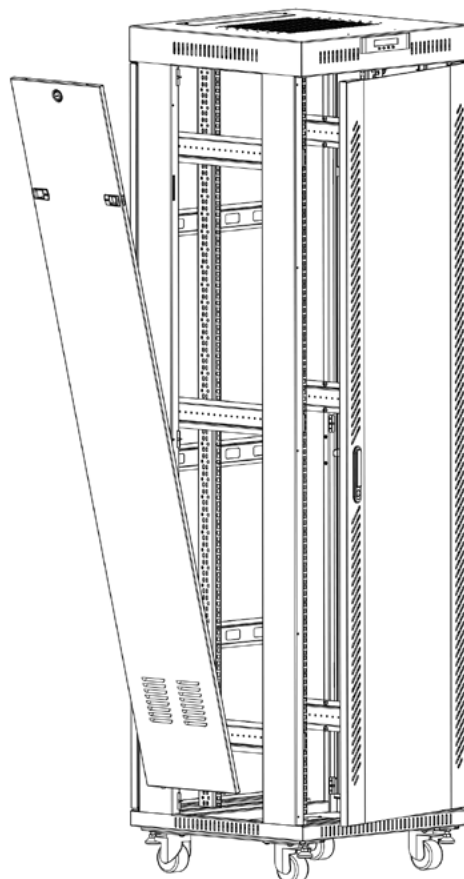
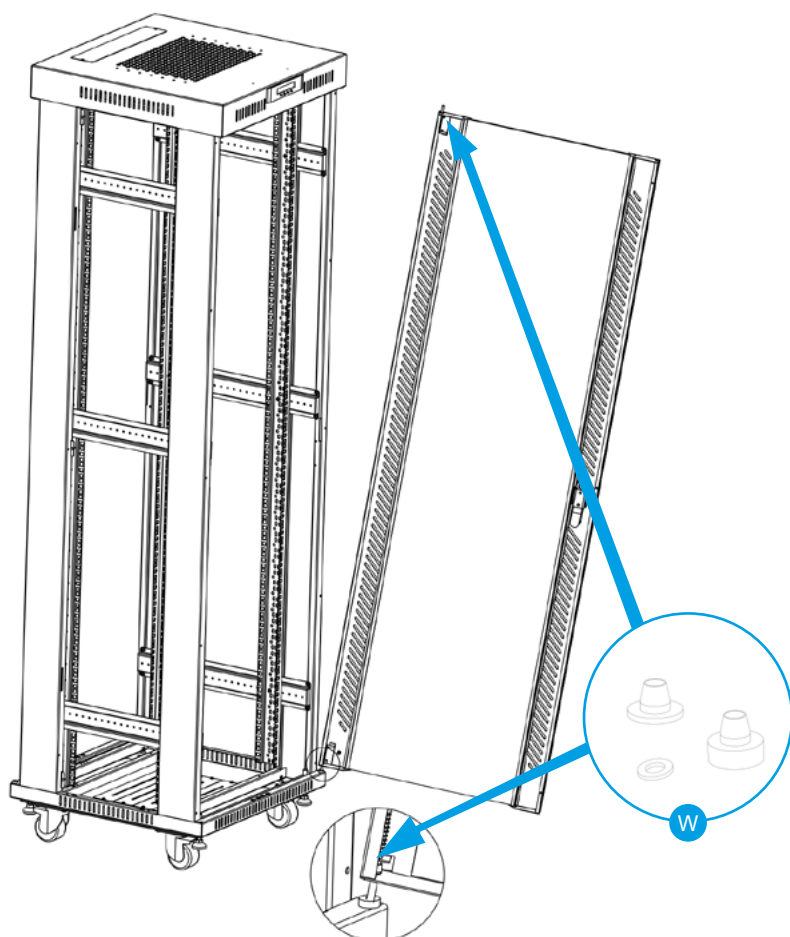



E-mail: support@lanberg.pl | support@lanberg.eu

www.lanberg.pl | www.lanberg.eu